

Version:  
January 12, 2017



**(FCR, RCA, RCN)**  
**Thick Film**  
**Chip Resistors**

**Token Electronics Industry Co., Ltd.**

**Taiwan:** No.137, Sec. 1, Zhongxing Rd., Wugu District,  
New Taipei City, Taiwan, R.O.C. 24872  
**Tel:** +886 2981 0109    **Fax:** +886 2988 7487

**China:** 12F, Zhong Xing Industry Bld., Chuang Ye Road,  
Nan Shan District, Shen Zhen City,  
Guang Dong, China 518054  
**Tel:** +86 755 26055363; **Fax:** +86 755 26055365

[Web: www.token.com.tw](http://www.token.com.tw)

<mailto:rfq@token.com.tw>



**▶ Product Introduction****Token makes Flip Chip, Resistor Networks, and Chip Array a green old age.****Features :**

- Tight Tolerance down to  $\pm 0.1\%$
- Wide R-Value Range  $10\ \Omega \sim 1\text{Meg}\ \Omega$
- Extremely Low TCR down to  $\pm 25\ \text{PPM}/^\circ\text{C}$
- Special Passivated NiCr Film for Anti-Acid and Anti-Damp
- Long Term Life Stability with Advance Thin Film Technology
- Demonstrated the Anti-Corrosion Claims Characterized by  $\text{Ta}_2\text{N}$

**Applications :**

- Telecommunication Device
- Automotive, Medical Equipment
- Outdoor Electronic Applications
- High-end Multimedia Electronics
- Automatic Equipment Controller
- High-end Computer, Industrial Equipment

Token has introduced precision surface-mount resistor networks, chip array, and flip-chips. Those no-lead packages are optimized to meet new automotive industry requirements for temperature and humidity, while offering high repeatability and stable performance for industrial, telecommunication, and consumer electronics.

Suitable for processing on automatic SMD assembly systems, those new devices are RoHS-compliant and compatible with lead (Pb)-free and tin/lead (Sn/Pb) reflow and vapor-phase soldering processes.

**Flip Chip Resistor FCR Series:**

- The resistor flip chip configurations (FCR Series) are available in industry standard EIA0603, EIA0805, and EIA1206.
- Power Rating 1/10W, 1/8W, and 1/4W are available in max. voltage 100V, 300V, and 300V respectively.
- Resistance tolerance is tight to F( $\pm 1\%$ ), J( $\pm 5\%$ ) with resistance range  $1\ \Omega$  to  $10\text{M}\ \Omega$ .

**Resistor Chip Array RCA Series:**

- Its small 1.6mm by 3.2mm package enables the design of high-density circuits.
- The resistor chip array (RCA Series) offers a low cost when compared to using four high-precision resistors.
- The devices feature precision ratio tolerances to F( $\pm 1\%$ ), G( $\pm 2\%$ ), and J( $\pm 5\%$ ) are available with resistance range  $10\ \Omega$  to  $1\text{M}\ \Omega$ .

**Resistor Networks RCN Series:**

- The (RCN) resistor networks offer a resistance range from  $10\ \Omega$  to  $1\text{M}\ \Omega$  at operating temperature range  $-55\ ^\circ\text{C} \sim +125\ ^\circ\text{C}$ .
- All devices offer power ratings of 1/16W at  $+70\ ^\circ\text{C}$  per resistor, custom configurations of the devices are available.

Full line products meet RoHS compliant. Detailed specifications, both mechanical and electrical, please contact our sales representative or link to Token official website "[Chip Resistors](http://www.token.com.tw)" for more information.



## ▶ FCR Dim

### Surface Mount Flip Resistor Dimensions (Unit: mm) (FCR)

Dimensions Type	L	W	H	L <sub>1</sub>	L <sub>2</sub>
FCR 03	1.60 ± 0.10	0.80 ± 0.10	0.45 ± 0.10	0.30 ± 0.20	0.30 ± 0.20
FCR 05	2.00 ± 0.15	1.25 ± 0.15	0.50 ± 0.10	0.40 ± 0.20	0.35 ± 0.15
FCR 06	3.10 ± 0.15	1.55 ± 0.15	0.55 ± 0.10	0.50 ± 0.25	0.50 ± 0.25

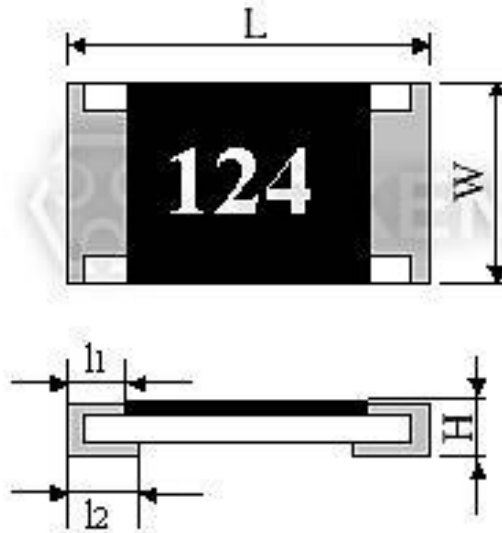

Thick Film Flip Chip Resistor (FCR) Dimensions

## ▶ RCA Dim.

### SMD Array Resistor Dimensions (Unit: mm) (RCA)

Dimensions Type	L	W	H	L <sub>1</sub>	L <sub>2</sub>	P	Q
RCA03-4D (0603)	3.2±0.2	1.6±0.15	0.5±0.1	0.30±0.15	0.35Max	0.8±0.1	0.5±0.1

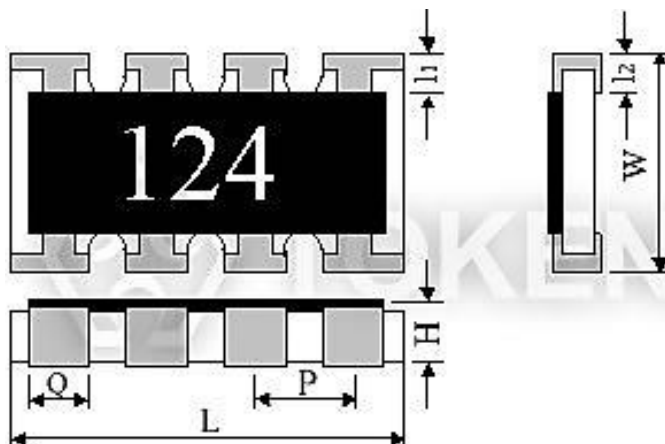

Thick Film Resistor Chip Array (RCA) Dimensions

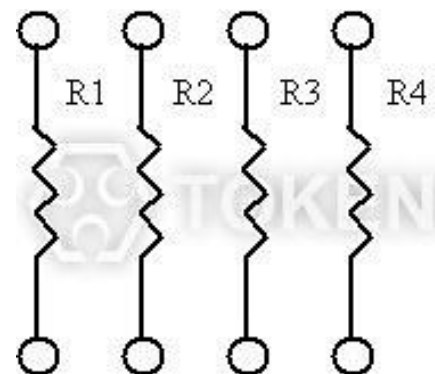

$$R1 = R2 = R3 = R4$$

Chip Array (RCA) Circuit

## RCN Dim.

### SMD Network Resistor Dimensions (Unit: mm) (RCN)

Dimensions Type	L	W	H	L <sub>1</sub>	L <sub>2</sub>	P	Q
RCN06-10R RCN06-10S	6.4 ± 0.2	3.1 ± 0.2	0.55 ± 0.1	0.5 ± 0.3	0.5 ± 0.2	1.27 ± 0.1	0.8 ± 0.2

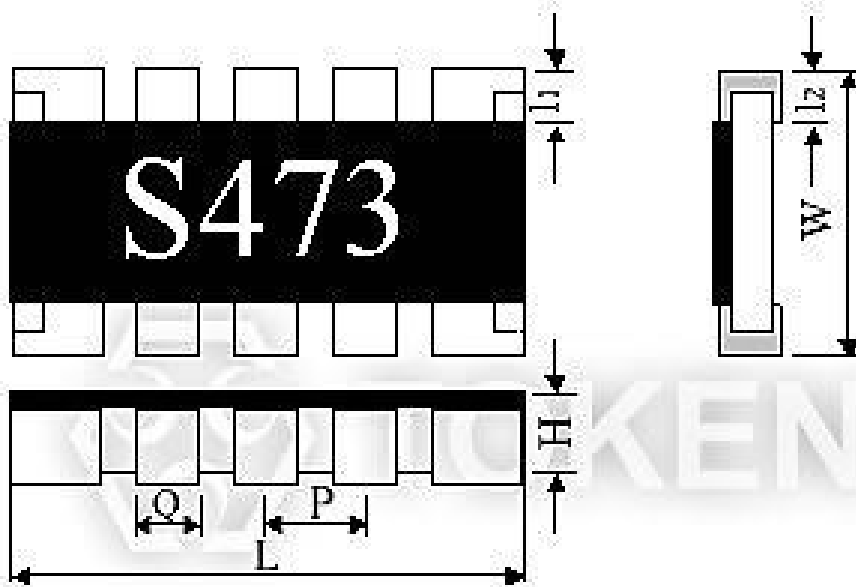

Resistor Chip Networks (RCN) Dimensions

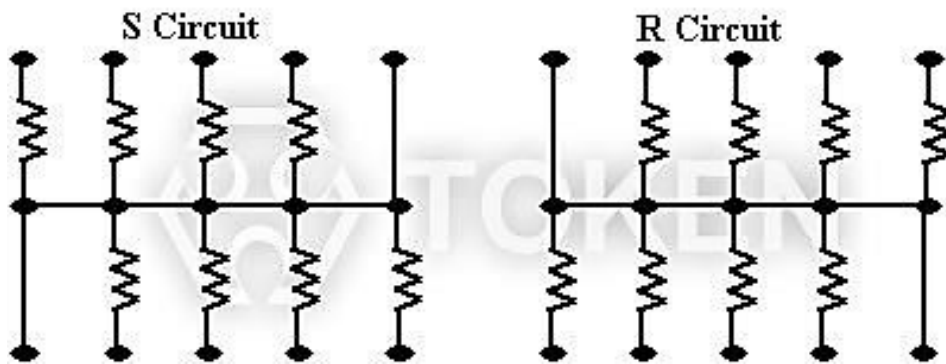

Chip Network (RCN) Circuit

## ► Electrical Spec.

### Electrical Specifications (FCR)

Type	Power Rating at 70°C	Max. RCWV	Max. Overload Voltage	Resistance Tolerance(%)	Resistance Range (Ω)		Standard Resistance Values
					Min.	Max.	
<b>FCR03</b>	1/10W	50V	100V	± 1% (F) ± 5% (J)	10Ω 1Ω	1MΩ 10MΩ	E-96 E-24
<b>FCR05</b>	1/8W	150V	300V	± 1% (F) ± 5% (J)	10Ω 1Ω	1MΩ 10MΩ	E-96 E-24
<b>FCR06</b>	1/4W	200V	300V	± 1% (F) ± 5% (J)	10Ω 1Ω	1MΩ 10MΩ	E-96 E-24

### Electrical Specifications (RCA)

Type	Rated Power at 70°C	Max. Working Voltage	Max. Overload Voltage	T.C.R. (ppm/°C)	Resistance Range(Ω)		Jumper Rated Current	Jumper Resistance Value	Operating Temperature Range
					F(±1%) E-96	G(±2%) J(±5%) E-24			
<b>RCA03-4D (0603)</b>	0.063	50V	100V	± 200	100~470K	10~1M	1A	50mΩ MAX	-55°C~+125°C

### Electrical Specifications (RCN)

Type	Rated Power at 70°C	Max. Working Voltage	Max. Overload Voltage	T.C.R. (ppm/°C)	Resistance Range	Number of Terminals	Number of Elements	Operating Temperature Range
					J (±5%) E-12			
<b>RCN06-10R RCN06-10S</b>	1/16W	50V	100V	±200	10Ω~1MΩ	10	8	-55°C~+125°C





## ► Environmental Characteristics

### Environmental Characteristics (FCR, RCA, RCN)

ITEM	SPECIFICATION	TEST METHOD
DC Resistance	J: $\pm 5\%$ , F: $\pm 1\%$	JIS C 5202 5.1
Temperature Coefficient of Resistance(TCR)	J: $\pm 200\text{ppm}/^\circ\text{C}$ F: $\pm 100\text{ppm}/^\circ\text{C}$	JIS C 5202 5.2 / IEC 115-1 4.8.4.2 T1 T2 Test temperature: $25^\circ\text{C} \rightarrow -55^\circ\text{C}$ $25^\circ\text{C} \rightarrow -55^\circ\text{C}$
Short Time Overload	J: $\Delta R \leq \pm (2\% + 0.1\Omega)$ F: $\Delta R \leq \pm (1\% + 0.05\Omega)$	JIS C 5202 5.5 / IEC 115-1 4.13 2.5xRated voltage (Max. Overload Voltage) for 5 sec. measure resistance after 30 minutes
Resistance to Solder Heat	J: $\Delta R \leq \pm (1\% + 0.1\Omega)$ F: $\Delta R \leq \pm (0.5\% + 0.05\Omega)$ No mechanical damage	JIS C 5202 6.4 / IEC 115-1 4.18 With $260 \pm 5^\circ\text{C}$ for $10 \pm 1$ sec.
Solderability	Over 95% of termination must be covered with solder	JIS C 5202 7.4 / IEC 115-1 4.17 After immersing flux, dip in the $235 \pm 5^\circ\text{C}$ molten solder bath for $2 \pm 0.5$ sec.
Temperature Cycle	J: $\Delta R \leq \pm (1\% + 0.1\Omega)$ F: $\Delta R \leq \pm (0.5\% + 0.05\Omega)$ No mechanical damage	JIS C 5202 7.4 / IEC 115-1 4.19 Repeat 5 cycles as follow $-55^\circ\text{C}$ (30minutes)+ $25^\circ\text{C}$ (10~15minutes) $+125^\circ\text{C}$ (30minutes)+ $25^\circ\text{C}$ (10~15minutes)
Terminal Strength	$\Delta R \leq \pm (0.5\% + 0.05\Omega)$ No mechanical damage	JIS C 5202 6.1 500g for 10 seconds
Load Life	J: $\Delta R \leq \pm (3\% + 0.1\Omega)$ F: $\Delta R \leq \pm (1\% + 0.05\Omega)$	JIS C 5202 7.10 / IEC 115-1 4.25.1 Permanent resistance change after 1000+48/-0 hours (1.5 hours ON, 0.5hour OFF) at RCWV or Max. Keep the element at $70 \pm 3^\circ\text{C}$ ambient
Load Life Humidity	J: $\Delta R \leq \pm (3\% + 0.1\Omega)$ F: $\Delta R \leq \pm (1\% + 0.05\Omega)$	JIS C 5202 7.9 / IEC 115-1 4.24.2 Maintain the temperature of the element at $40 \pm 2^\circ\text{C}$ and 90~95% RH with the rated voltage applied. Cycle ON for 1.5hours and Off for 0.5hour for 1000+48/-0 hours. After one hour, measure the resistance value.
Intermittent Overload	$\Delta R \leq \pm (5\% + 0.1\Omega)$ No mechanical damage	JIS C 5202 5.8 2.5xRated Voltage (Max. Overload Voltage), 1secON, 25sec OFF, test 10,000 cycles

## ▶ Marking

### Marking (FCR, RCA, RCN)

			
3 digit marking for E24 (J) 100 ~ 10Ω 122 ~ 1.2KΩ 473 ~ 47KΩ 105 ~ 1MΩ	4 digit marking for E96 (F) 22R1 ~ 22.1Ω 1020 ~ 102Ω 1542 ~ 15.4KΩ	3 digit marking for E96 (F) 02C $102 \times 10^2 = 10.2K\Omega$	15E $140 \times 10^4 = 1.4M\Omega$

**SMD Resistor Marking**



## ▶ Tape & Packaging

### Tape Specifications (Unit: mm) (FCR, RCA, RCN)

TYPE	A	B	W	F	E	P <sub>1</sub>	P <sub>2</sub>	P <sub>0</sub>	D	G
<b>FCR03</b>	1.10±0.20	1.90±0.20	8.0±0.3	3.50±0.05	1.75±0.10	4.0±0.1	2.00±0.05	4.0±0.1	1.5±0.1	2.75
<b>FCR05</b>	1.65±0.20	2.45±0.20	8.0±0.3	3.50±0.05	1.75±0.10	4.0±0.1	2.00±0.05	4.0±0.1	1.5±0.1	2.75
<b>FCR06</b>	2.00 <sup>+0.10</sup> <sub>-0.15</sub>	3.57 <sup>+0.10</sup> <sub>-0.15</sub>	8.0±0.3	3.50±0.05	1.75±0.10	4.0±0.1	2.00±0.05	4.0±0.1	1.5±0.1	2.75

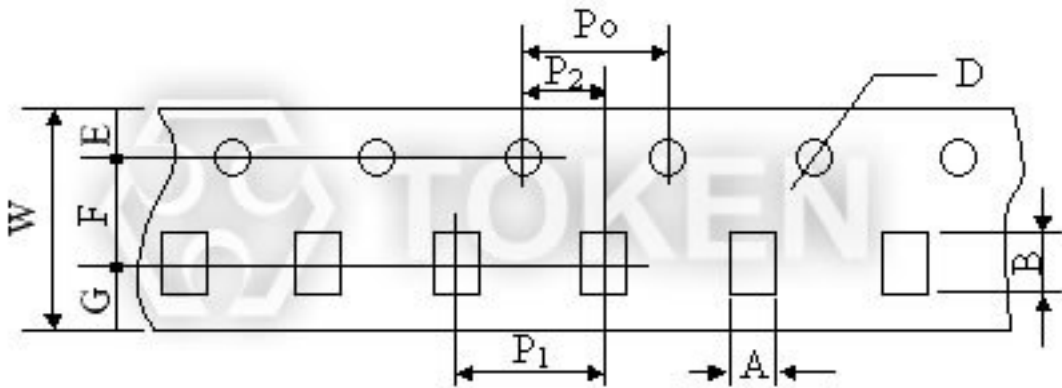

SMD Surface Mount Tape Dimensions

### Reel Packaging (Unit: mm) (FCR, RCA, RCN)

Symbol	A	B	C	D	G	N	T
<b>Dimension</b>	178 ± 2.0	20 ± 0.5	13.0 ± 0.5	20 min.	100 ± 1.5	80.0 ± 0.5	14.9 max.

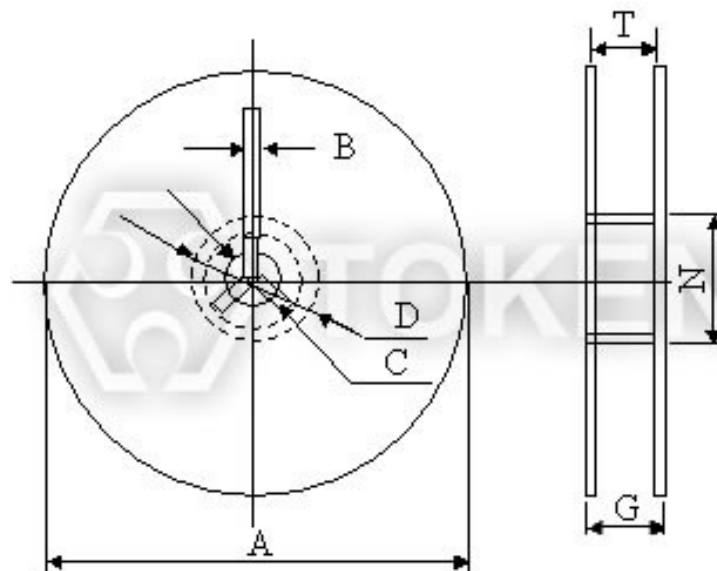

Reel Packaging Dimensions



## Order Codes

### Order Codes Flip SMD Resistors (FCR)

FCR	03		100			J	TR			
Part Number	Size (mm)		Nominal Resistance			Resistance Tolerance (%)		Package		
FCR	03	1.60×0.80	SMD Elements	3-Digit	E24 Series EX 10Ω=100 47Ω=470	F	±1%		TR	Taping Reel
	05	2.00×1.25			4-Digit	E96 Series EX 10.2Ω=10R2 10KΩ=1002	J	±5%		P
	06	3.10×1.55		Jumper			000			

### Order Codes Resistor SMD Array (RCA)

RCA	03		-	4	D	101		J	TR					
Part Number	Size(mm)			Number of circuits	Electrode Structure		Nominal Resistance		Resistance Tolerance (%)		Package			
RCA	03	3.20×1.60		4	4 circuits	D	protruding electrode	SMD Elements	3-Digit	E24 Series EX 10Ω=100 47Ω=470	F	±1%	TR	Taping Reel
									4-Digit	E96 Series EX 10.2Ω=10R2 10KΩ=1002	G	±2%	P	Bulk
									Jumper		000	J	±5%	

### Order Codes SMD Resistor Networks (RCN)

RCN	06		-	10	R	103		J	TR				
Part Number	Size (mm)			Number of Terminals	Circuit Structure		Nominal Resistance		Resistance Tolerance (%)		Package		
RCN	06	6.40×3.10		10	R	circuit	3-Digit	E12 Series EX 10Ω=100 100Ω=101	J	±5%		TR	Taping Reel
					S	circuit			P	Bulk			

## ► General Information

### **Token Thin Film Chips Add Powerful New Options**

Token electronics provides the industry's most comprehensive range of precision thin film technologies for discrete, network, and integrated passive components used in instrumentation; automotive electronics; communications systems; and portable electronics applications. Ultra-reliable precision Nichrome resistive elements are available on ceramic or silicon substrates in a wide variety of surface mount resistors.

In response to market demands for increased precision and stability, Token has expanded range of nichrome thin-film chip resistors. Offering solutions to precision test and measurement and voltage regulation across industrial, military and medical monitoring equipment markets designed to offer superior humidity performance.

### **Token Thick Film Chips Cut the Cost of Precision Resistors**

Token electronics has developed an extensive range of thick film / thin film resistive technologies for electronic circuits in power supplies; test and measurement; industrial electronics; telecommunications; audio circuits; automotive control systems; lighting controls; medical electronics; industrial equipment; and control systems applications.

In addition to this, proven thick film technologies from Token electronics provide a large range of standard resistive low Ohmic current sense products for critical battery management, and line termination. The enhanced performance of the chips is made possible by the precise use of the best resistance inks and a closely controlled production process.

### **Token Chip Low Ohmic Resistors come in Smaller Sizes and Minimized Power Consumption**

Today's electronic devices are becoming smaller and smaller. As a result, designers are moving more towards surface mount components not only for new designs but also to design out large axial and other through-hole resistors.

In most cases this is a straight forward task as several resistor manufacturers offer chip resistors with performances to match axial parts. However in some cases, due to power rating or pulse withstanding requirements, this has been impossible. The requirement, in particular, for pulse withstand capability is growing due to the need to protect sensitive modern electronic systems. To meet this demand Token electronics have designed a Pulse Withstanding Chip Resistor (PWR Series).

