

Version:  
July 12, 2018



# **(LRF) 4-Terminal Connection Kelvin Current Sensing Chips**

**Token Electronics Industry Co., Ltd.**

**Taiwan:** No.137, Sec. 1, Zhongxing Rd., Wugu District,  
New Taipei City, Taiwan, R.O.C. 24872  
**Tel:** +886 2981 0109    **Fax:** +886 2988 7487

**China:** 12F, Zhong Xing Industry Bld., Chuang Ye Road,  
Nan Shan District, Shen Zhen City,  
Guang Dong, China 518054  
**Tel:** +86 755 26055363; **Fax:** +86 755 26055365

**Web:** [www.token.com.tw](http://www.token.com.tw)

**Email:** [rfq@token.com.tw](mailto:rfq@token.com.tw)



## ▶ Product Introduction

**A key current sensing technology of 4-terminal Kelvin resistor (LRF) to construct vehicles for road, rail, sea, air and space.**

### Features :

- 4-Terminal Kelvin design, Durable with all-welded construction.
- Solid metal strip nickel-chrome or manganese-copper alloy resistive element.
- Ideal for all types of current sensing, voltage division and pulse applications.
- Proprietary processing technique produces extremely low resistance values.
- Over Coating : molding Compound UL-94 grade.

### Applications :

- Automotive: Electronic controls (engine and transmission controls, audio electronics, climate controls, anti-lock brakes, etc.).
- Computer: Power management / safety, DC/DC converter, VRMs, Li-Ion battery management.
- Telecommunications: Power management in cell phones.
- Industrial: Instrumentation, inverter air conditioning.

Token extends its surface-mount current sensing series with (LRF). This 4-terminal connection Kelvin chip resistor derivative in 1/2 watt and 1 watt package sizes. TCR down to 150ppm and enables tight tolerances down to 1% for increased measurement accuracy. Token LRF0612 combines tight tolerance and low TCR with extremely low resistance values down to 0.5mΩ in the compact 0612 case size.

Employing the same Ni-Cu or Mn-Cu resistive element this product affords the user an added advantage of a built in 4-terminal design with 2 larger electrodes for current management and 2 smaller electrodes for voltage measurement. This results in a pulse tolerant, tight tolerance resistor in the 0612 package size that maintains the superior electrical characteristics of the surface-mount construction.

With its 4-terminal construction, the device reduces system errors while eliminating the need for system calibration. Also, LRF's low resistance value minimises excess power dissipation while its tight tolerance and low TCR improve circuit accuracy by reducing measurement error or eliminating the need for calibration during manufacturing or in the field, which reduces costs and/or improves end product performance.

The LRF0612 is suitable for all types of voltage division, current sensing, and pulse applications in power management for cell phones; VRMs for laptops, DC/DC converters for servers, and Li-Ion battery management and safety; industrial instrumentation; and automotive electronic control such as audio, transmission, anti-lock brakes, engine, and climate controls.

Like all current sensing chip resistors, LRF0612 features an all-welded construction that contributes to its superior electrical performance. A proprietary processing technique produces extremely low resistance values ranging from 0.5mΩ to 5mΩ, with tight tolerances of 1%, 2% and 5%. The device is lead-free, RoHS-compliant, and Token Green. For non-standard technical requirements and special applications, contact us with your specific needs. Or link to Token official website "[Current Sense Resistors](http://www.token.com.tw)".



## Construction & Dimensions

### Dimensions Unit: mm (LRF)

Type	Power Rating at 70 °C (W)	Resistance Range (mΩ)	L±0.2 (mm)	W±0.25 (mm)	H±0.2 (mm)	T±0.25 (mm)	A±0.13 (mm)	B±0.13 (mm)
LRF0612	1/2	0.5~5	1.65	3.05	0.65	0.4	0.51	0.51
LRF0612	1	0.5~5	1.65	3.05	0.65	0.4	0.51	0.51



(LRF) Kelvin Current Sensing Chips Dimensions (Unit: mm)

## Electrical Specifications

### Recommend Land Pattern (LRF)

Type	Maximum Power Rating (Watts: W)	Resistance Range (mΩ)	Dimensions (mm ± 0.1)				
			A	B	C	L	F
LRF0612	1/2W, 1W	0.5 ~ 5	2.3	1.0	0.8	0.7	0.4

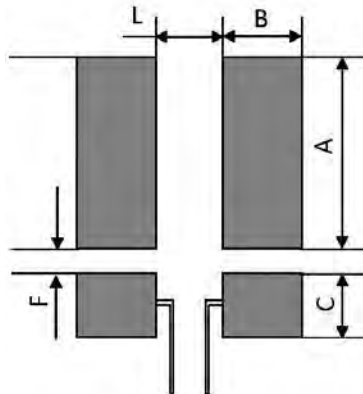

4-Terminal Connection Kelvin Recommend Land Pattern (LRF)

- \* Remark: Copper foil minimum thickness of PCB: 3oz

### Electrical Characteristics (LRF)

Type	Power Rating at 70°C	Maximum working voltage (V)	Resistance Range (mΩ)	TCR (ppm/°C)	Tolerance (%)	Operating Temperature Range
LRF0612	1/2W, 1W	(P x R)1/2	0.5mΩ ≤ R ≤ 3mΩ	±200	±1%, ±2%, ±5%	-55°C ~ +170°C
			3mΩ ≤ R ≤ 5mΩ	±150		

## Reel & Type

### Packing Quantity & Reel Specifications (LRF)

Type	Packaging Quantity	Tape Width	Reel Diameter	ΦA (mm)	ΦB (mm)	ΦC (mm)	W (mm)	T (mm)
LRF0612	4,000 pcs	8 mm	7 inch	178.5±2.5	60.0±1.0	13.0±1.0	9.0±1.0	11.5±1

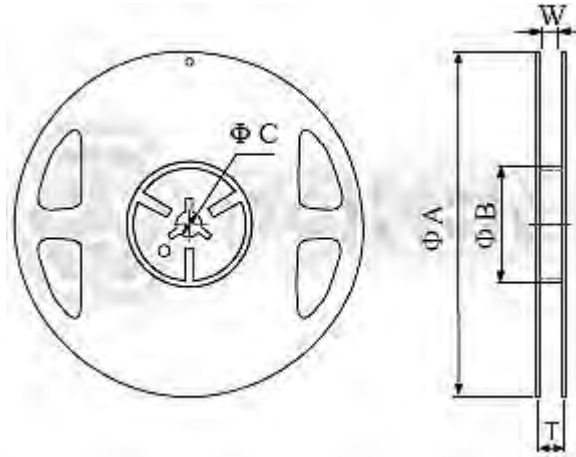

Reel Specifications Dimensions

### Emboss Plastic Tape Specifications (LRF)

Type	A (mm)	B (mm)	W (mm)	E (mm)	F (mm)	P0 (mm)	P1 (mm)	P2 (mm)	ΦD0 (mm)	ΦD1 (mm)	T (mm)
LRF0612	3.50±0.10	6.70±0.10	12.0±0.30	1.75±0.10	5.5±0.05	4.0±0.10	4.0±0.10	2.0±0.05	1.50±0.10	1.50±0.25	1.2±0.15

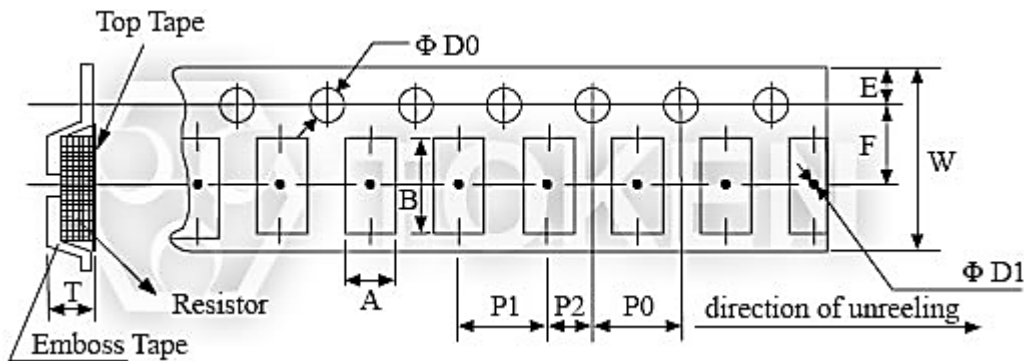

Low Ohm 4-Terminal Connection (LRF) Emboss Plastic Tape Specifications

● Notice :

1. The cumulative tolerance of 10 sprocket hole pitch is ±0.2mm.
2. Carrier camber shall be not more than 1mm per 100mm through a length of 250mm.
3. A & B measured 0.3mm from the bottom of the packet.
4. t measured at a point on the inside bottom of the packet to the top surface of the carrier.
5. Pocket position relative to sprocket hole is measured as the true position of the pocket and not the pocket hole.

## Derating & Reflow

### Derating Curve

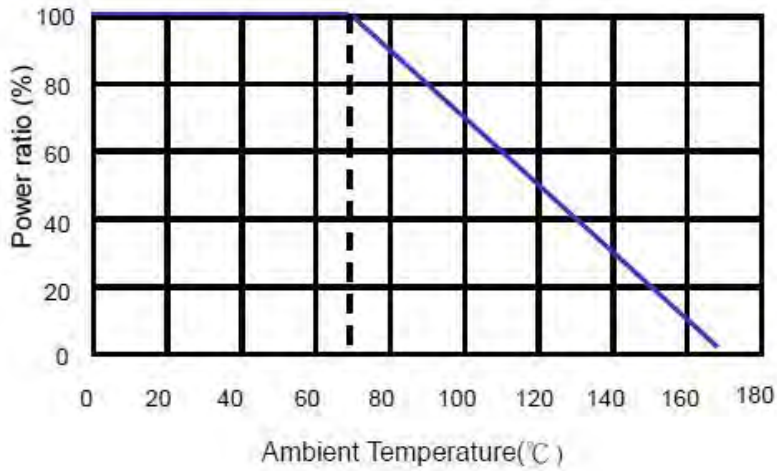

Kelvin Current Sensing Chips (LRF) - Derating Curve

### Reflow Condition

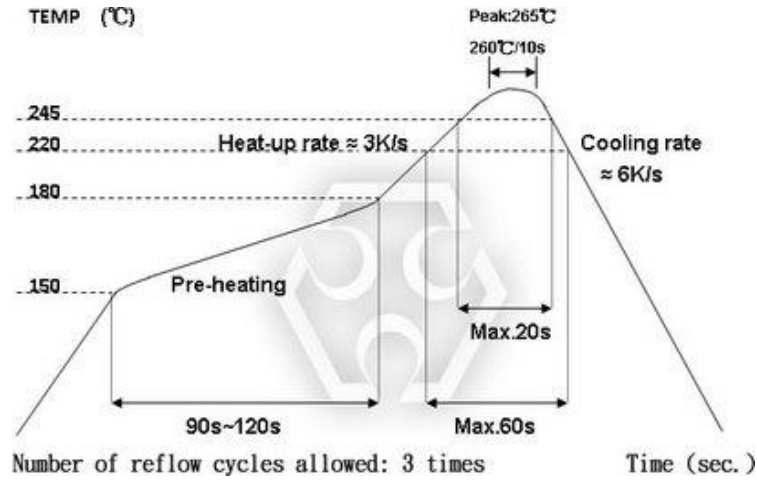

4-Terminal Current Chips (LRF) - Reflow Soldering (IR)

## Environmental Characteristics

### Environmental Characteristics (LRF)

Item	Requirement	Test Method
Temperature Coefficient of Resistance (T.C.R.)	As Spec.	IEC60115-1 4.8 JIS-C-5201-1 4.8 -55°C ~+125°C, 25°C is the reference temperature.
Short Time Overload	±1%	IEC60115-1 4.13 JIS-C-5201-1 4.13 5*rated power for 5 seconds.
Insulation Resistance	>100MΩ	IEC60115-1 4.6 JIS C 5201-1 4.6 100V DC for 1 minute
Endurance	±2.0%	IEC60115-1 4.25 JIS-C-5201-1 4.25.1 70±2°C, RCWV for 1000 hrs with 1.5 hrs "ON" and 0.5 hrs "OFF"
Moisture no Load	±1%	IEC60115-1 4.24.2.1a JIS-C-5201-1 4.24.2.1a 85°C, 85%RH, 1000 Hrs.
High Temperature Exposure	±2.0%	IEC60115-1 4.23.2 JIS-C-5201-1 4.23.2 At +170°C for 1000 Hrs.
Low Temperature Storage	±1%	IEC60115-1 4.23.4 JIS C 5201-1 4.23.4 At -55°C for 1000 Hrs.
Bending Strength	±1%	IEC-60115-1 4.33 JIS-C-5201-1 4.33 Bending width 2mm once for 5 seconds.
Solderability	95% Min. coverage	IEC-60115-1 4.17 JIS-C-5201-1 4.17 245±5°C for 2±0.5 seconds.
Resistance to Soldering Heat	±0.5%	IEC-60115-1 4.18 JIS-C-5201-1 4.18 260±5°C for 10±1 sec 2 cycles.
Thermal Shock	±1%	IEC-60115-1 4.19 JIS-C-5201-1 4.19 -55°C ~ 150°C, 300 cycles, 15min per extreme condition.

## Order Codes

### Order Codes (LRE)

LRF	0612	F	TR	F	T	0m75	M
Part Number	Dimensions (L×W) (mm)	Resistance Tolerance (%)	Package	TCR (PPM/°C)	Power Rating (W)	Resistance (Ω) Ex:	Marking
0612	1.65*3.05	J ±5 G ±2 F ±1	TR Taping Reel	K ±150 F ±200	U 0.5W T 1W	0m50 0.00050 0m75 0.00075 1m50 0.00150 R005 0.00500	M MnCu Material NiCu Material

## General Information

### Your Current Options - Token Current Sense

As the world becomes more and more technology-driven, the uses for current sensing components will continue to increase. The need for even lower resistance value ranges is already becoming evident, as is the need for these resistors to handle more power. The industry-wide trend is the emergence of smaller and smaller products.

Token Electronics offers a wide variety of current sensing products from the industry to military standards, such as current sense in Thin-Film / Thick-Film Technology, Bare Element Resistors, and Open Air Shunts. This enables Token to present an astounding number of possible solutions for any circuit design needs.

### Applications of Current Detecting Components

Token's TCS and CS Series unique form factor provides automotive designers with several advantages. Both TCS and CS Series are ideal for applications involving window lift motors, fuel pump systems, seat belt pretensioners, and pulse width modulator feedback.

The wider resistive element and lower resistance enables higher current to pass through the device. Token's LRC ultra low Ohmic metal strip chip series provides the inherent ability to flex slightly and offers stress relief during extreme temperature cycling on typical or metal substrates. This LRC series is suitable for switch power supply applications (DC-DC Converter, Charger, and Adaptor) and power management of monitor.

The open air design of bare element resistor LRA and LRB Series provide a far cooler operation by allowing more air flow under the resistive element to keep excess heat from being transmitted to the PC board. They are suitable for high power AC/DC detection of power supply circuit.

Token axial moulded BWL series provides power rating up to 10 watts and lower resistance 0.005Ω, is ideal for all types of current sensing applications including switching and linear power supplies, instruments and power amplifiers.

Token standard current sensing components can be replacement for Vishay, IRC, Ohmite, KOA, Yageo devices with fast delivery and more competitive price. Contact us with your specific needs.

