

Version:
August 6, 2018



(TPSME) Miniature Low Profile Power Inductors

Token Electronics Industry Co., Ltd.

Taiwan: No.137, Sec. 1, Zhongxing Rd., Wugu District,
New Taipei City, Taiwan, R.O.C. 24872
Tel: +886 2981 0109 Fax: +886 2988 7487

China: 12F, Zhong Xing Industry Bld., Chuang Ye Road,
Nan Shan District, Shen Zhen City,
Guang Dong, China 518054
Tel: +86 755 26055363; Fax: +86 755 26055365

[Web: www.token.com.tw](http://www.token.com.tw)

[Email: rfq@token.com.tw](mailto:rfq@token.com.tw)



▶ Product Introduction**Token (TPSME) Miniature Low Profile Power Inductor for new generation portable products.****Features :**

- Low Profile: 1.0mm ~ 4.5mm.
- Excellent solderability and high heat resistance.
- High current (rated current): 0.34 to 15.0 amperes.

Applications :

- DC-DC converters, DVD, DSC, phone, PDA, GPS, CMMB, Digital photo Frame, telephone, CAR AV equipment.

Token Electronics has added new ranges of low-profile wire wound chip inductors, TPSME201610, TPSME252010, TPSME252012, TPSME3010, TPSME3012, TPSME3015, TPSME4012, TPSME4018, TPSME4030, TPSME5020, TPSME6020, TPSME6028, TPSME6045, and TPSME8040, for use in DC-DC converter applications to increase flexibility of maximum height measurements with extended electrical characteristics.

The new TPSME series is designed to provide a good balance of height and performance within chip power miniature inductor offering. The TPSME201610, TPSME252010, and TPSME3010 Series were developed to have a low profile height of 1.0mm. The TPSME252012, TPSME3012, and TPSME4012 Series were developed to have a medium range maximum height of 1.2mm. Those TPSME family enables flexibility and efficiency.

All TPSME winding chip coils of inductors offer low DC resistance and large rated current. This is vital for DC-DC converter applications as it prevents energy dissipation from the chip inductor, improving the converter's overall efficiency.

The new ranges deliver a good size/performance ratio with low DC resistances of 0.010ohm (TPSME6045) and 0.025ohm (TPSME252012). A wide range of inductances is also available from 0.24μH to 330μH. The parts come with high rated currents, up to 15A, and feature magnetic shielding as standard. Operating temperature range is -55°C to +125°C.

Custom parts are available on request. Token will also produce devices outside these specifications to meet specific customer requirements, please contact our sales or link to Token official website "[SMD Power Inductors](http://www.token.com.tw)" for more information.



► Dimensions

Dimensions & Configurations (Unit: mm) (TPSME)

Series	Dimensions (mm)					Fig
	A	B	C Max.	D Ref.	E Ref.	
201610	2.0 ± 0.2	1.6 ± 0.2	1.0	0.6	0.6	Fig1/Fig2
252010	2.5 ± 0.2	2.0 ± 0.2	1.0	0.8	0.8	Fig1
252012	2.5 ± 0.2	2.0 ± 0.2	1.2	0.8	0.8	Fig1
3010	3.0 ± 0.2	3.0 ± 0.2	1.0	1.5	0.75	Fig2
3012	3.0 ± 0.2	3.0 ± 0.2	1.2	1.5	0.75	Fig2
3015	3.0 ± 0.2	3.0 ± 0.2	1.5	1.5	0.75	Fig2
4012	4.0 ± 0.2	4.0 ± 0.2	1.2	2.1	0.95	Fig2
4018	4.0 ± 0.2	4.0 ± 0.2	1.8	2.1	0.95	Fig3
4030	4.0 ± 0.2	4.0 ± 0.2	3.0	2.1	0.95	Fig3
5020	5.0 ± 0.2	5.0 ± 0.2	2.0	2.4	1.30	Fig3
5040	5.0 ± 0.2	5.0 ± 0.2	4.0	2.4	1.30	Fig2
6020	6.0 ± 0.5	6.0 ± 0.5	2.5	2.5	1.75	Fig3
6028	6.0 ± 0.3	6.0 ± 0.3	3.3	2.5	1.75	Fig3
6045	6.0 ± 0.2	6.0 ± 0.2	4.5	2.9	0.95	Fig3
8040	8.0 ± 0.2	8.0 ± 0.2	4.0	4.0	1.6	Fig2/Fig3

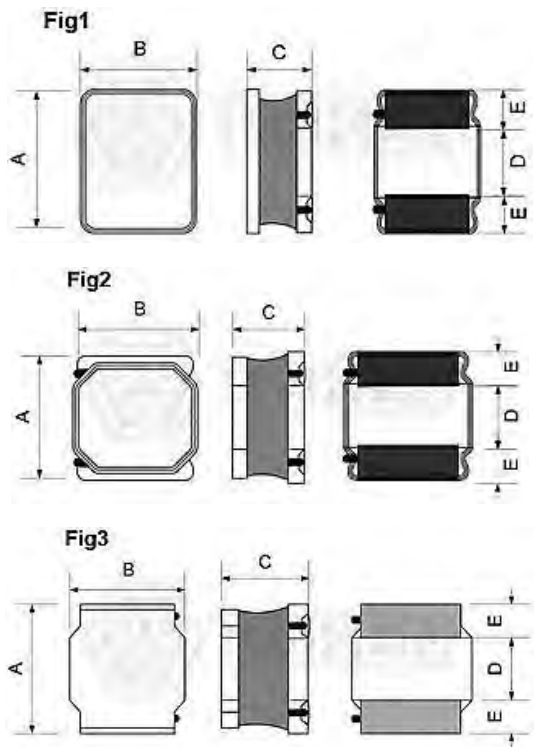

▶ 201610

Electrical Specification (TPSME201610)

Part Number	L (μH)	Tolerance (±%)	DCR (Ω) Max.	IDC Typ. (A)	
				Heat Rating Current DC Amps. Idc (A) L↓30%	Saturation Current DC Amps. Isat (A) L↑40°C
TPSME201610-R24M	0.24	20	0.034	3.80	3.80
TPSME201610-R33M	0.33	20	0.052	3.70	3.50
TPSME201610-R47M	0.47	20	0.059	2.90	2.50
TPSME201610-R68M	0.68	20	0.078	2.20	2.40
TPSME201610-1R0M	1.00	20	0.104	1.90	2.00
TPSME201610-2R2M	2.20	20	0.120	1.00	1.40
TPSME201610-4R7M	4.70	20	0.396	0.90	1.00
TPSME201610-100M	10.00	20	0.956	0.70	0.70

Electrical Specification (TPSME201610 H Series)

Part Number	L (μH)	Tolerance (±%)	DCR (Ω) Max.	IDC Typ. (A)	
				Heat Rating Current DC Amps. Idc (A) L↓30%	Saturation Current DC Amps. Isat (A) L↑40°C
TPSME201610HR24M	0.24	20	0.032	4.20	4.30
TPSME201610HR33M	0.33	20	0.041	3.80	3.80
TPSME201610HR47M	0.47	20	0.059	2.90	2.50
TPSME201610HR68M	0.68	20	0.078	2.20	2.40
TPSME201610H1R0M	1.00	20	0.072	2.00	2.25
TPSME201610H2R2M	2.20	20	0.215	1.35	1.40
TPSME201610H4R7M	4.70	20	0.420	1.00	1.00
TPSME201610H100M	10.00	20	0.820	0.65	0.70

Electrical Specification (TPSME201610 E Series)

Part Number	L (μH)	Tolerance (±%)	DCR (Ω) Max.	IDC Typ. (A)	
				Heat Rating Current DC Amps. Idc (A) L↓30%	Saturation Current DC Amps. Isat (A) L↑40°C
TPSME201610ER24M	0.24	20	0.032	4.85	4.30
TPSME201610ER47M	0.47	20	0.042	3.60	3.00
TPSME201610ER68M	0.68	20	0.058	3.00	3.00
TPSME201610E1R0M	1.00	20	0.070	2.20	2.60
TPSME201610E1R5M	1.50	20	0.120	1.70	2.00
TPSME201610E2R2M	2.20	20	0.150	1.60	1.60

Electrical Specification (TPSME201610 A Series)

Part Number	L (μH)	Tolerance (±%)	DCR (Ω) Max.	IDC Typ. (A)	
				Heat Rating Current DC Amps. Idc (A) L↓30%	Saturation Current DC Amps. Isat (A) L↑40°C
TPSME201610AR24M	0.24	20	0.032	5.50	4.30
TPSME201610AR33M	0.33	20	0.032	4.60	3.80
TPSME201610AR47M	0.47	20	0.042	4.40	3.50
TPSME201610AR68M	0.68	20	0.057	3.40	3.00
TPSME201610A1R0M	1.00	20	0.090	3.15	2.40
TPSME201610A1R5M	1.50	20	0.130	2.20	2.00
TPSME201610A2R2M	2.20	20	0.165	2.10	1.45

Electrical Specification (TPSME201610 IH Series)

Part Number	L (μH)	Tolerance (±%)	DCR (Ω) Max.	IDC Typ. (A)	
				Heat Rating Current DC Amps. Idc (A) L↓30%	Saturation Current DC Amps. Isat (A) L↑40°C
TPSME201610IHR24M	0.24	20	0.026	7.00	4.50
TPSME201610IHR33M	0.33	20	0.029	6.00	4.00
TPSME201610IHR47M	0.47	20	0.036	4.50	3.80
TPSME201610IHR68M	0.68	20	0.050	4.00	3.10
TPSME201610IH1R0M	1.00	20	0.072	3.40	2.85
TPSME201610IH1R5M	1.50	20	0.120	2.20	2.10
TPSME201610IH2R2M	2.20	20	0.155	2.20	1.70

Remark:

- The part temperature (ambient +temp rise) should not exceed 125°C under the worst case operating conditions. Circuit Design, component placement, PWB trace size and thickness, airflow and other cooling provision all affect the part Temperature. Part temperature should be verified in the application. The rated current as listed is either the saturation current or the heating current depending on which value is lower.

Note TPSME201610 All Series:

- All test data is referenced to 25°C ambient. Test condition: 100KHZ, 0.1Vrms.
- Irms: DC current(A) that will cause an approximate Δt of 40°C.
- Isat: DC current(A) that will cause L0 to drop approximately 30%.
- Operating Temperature Range -55°C to +125°C.



▶ 252010

Electrical Specification (TPSME252010)

Part Number	L (μH)	Tolerance (±%)	DCR (Ω) Max.	IDC Typ. (A)	
				Heat Rating Current DC Amps. Idc (A) L↓30%	Saturation Current DC Amps. Isat (A) L↑40°C
TPSME252010-R47M	0.47	20	0.056	3.40	2.70
TPSME252010-R68M	0.68	20	0.056	2.90	2.70
TPSME252010-1R0M	1.00	20	0.078	2.55	2.30
TPSME252010-2R2M	2.20	20	0.186	1.70	1.65
TPSME252010-3R3M	3.30	20	0.300	1.30	1.45
TPSME252010-4R7M	4.70	20	0.456	1.20	0.90
TPSME252010-6R8M	6.80	20	0.540	1.00	0.85
TPSME252010-100M	10.00	20	0.660	0.90	0.70
TPSME252010-220M	22.00	20	1.600	0.60	0.55
TPSME252010-470M	47.00	20	2.400	0.35	0.35

Electrical Specification (TPSME252010 H Series)

Part Number	L (μH)	Tolerance (±%)	DCR (Ω) Max.	IDC Typ. (A)	
				Heat Rating Current DC Amps. Idc (A) L↓30%	Saturation Current DC Amps. Isat (A) L↑40°C
TPSME252010HR47M	0.47	20	0.042	3.60	3.50
TPSME252010HR68M	0.68	20	0.058	3.20	3.20
TPSME252010H1R0M	1.00	20	0.072	2.70	2.70
TPSME252010H2R2M	2.20	20	0.142	1.70	1.75
TPSME252010H3R3M	3.30	20	1.50	1.50	1.25

Electrical Specification (TPSME252010 E Series)

Part Number	L (μH)	Tolerance (±%)	DCR (Ω) Max.	IDC Typ. (A)	
				Heat Rating Current DC Amps. Idc (A) L↓30%	Saturation Current DC Amps. Isat (A) L↑40°C
TPSME252010ER24M	0.24	20	0.030	5.50	4.30
TPSME252010ER33M	0.33	20	0.038	4.05	3.90
TPSME252010ER47M	0.47	20	0.038	3.90	3.90
TPSME252010ER68M	0.68	20	0.053	3.50	3.20
TPSME252010E1R0M	1.00	20	0.072	2.60	2.60
TPSME252010E1R5M	1.50	20	0.103	2.20	2.10
TPSME252010E2R2M	2.20	20	0.155	1.90	1.90
TPSME252010E3R3M	3.30	20	0.210	1.60	1.50
TPSME252010E4R7M	4.70	20	0.318	1.30	1.20
TPSME252010E6R8M	6.80	20	0.470	0.10	1.10
TPSME252010E100M	10.00	20	0.600	0.80	0.80

Electrical Specification (TPSME252010 A Series)

Part Number	L (μH)	Tolerance (±%)	DCR (Ω) Max.	IDC Typ. (A)	
				Heat Rating Current DC Amps. Idc (A) L↓30%	Saturation Current DC Amps. Isat (A) L↑40°C
TPSME252010AR24M	0.24	20	0.030	6.55	4.20
TPSME252010AR33M	0.33	20	0.026	6.50	5.00
TPSME252010AR47M	0.47	20	0.038	5.50	4.00
TPSME252010AR68M	0.68	20	0.050	4.15	3.90
TPSME252010A1R0M	1.00	20	0.065	3.55	3.00
TPSME252010A1R5M	1.50	20	0.100	3.00	2.35
TPSME252010A2R2M	2.20	20	0.130	2.30	2.00
TPSME252010A4R7M	4.70	20	0.310	1.60	1.35

Electrical Specification (TPSME252010 IH Series)

Part Number	L (μH)	Tolerance (±%)	DCR (Ω) Max.	IDC Typ. (A)	
				Heat Rating Current DC Amps. Idc (A) L↓30%	Saturation Current DC Amps. Isat (A) L↑40°C
TPSME252010IHR24M	0.24	20	0.018	8.90	6.50
TPSME252010IHR33M	0.33	20	0.024	7.50	5.50
TPSME252010IHR47M	0.47	20	0.030	6.50	4.70
TPSME252010IHR68M	0.68	20	0.040	5.60	4.20
TPSME252010IH1R0M	1.00	20	0.053	4.60	4.00
TPSME252010IH1R5M	1.50	20	0.075	3.80	3.30
TPSME252010IH2R2M	2.20	20	0.097	3.00	2.70
TPSME252010IH4R7M	4.70	20	0.250	1.70	1.50

Electrical Specification (TPSME252010 AH Series)

Part Number	L (μH)	Tolerance (±%)	DCR (Ω) Max.	IDC Typ. (A)	
				Heat Rating Current DC Amps. Idc (A) L↓30%	Saturation Current DC Amps. Isat (A) L↑40°C
TPSME252010AHR24M	0.24	20	0.027	7.10	4.60
TPSME252010AHR33M	0.33	20	0.027	5.30	4.40
TPSME252010AHR47M	0.47	20	0.035	6.00	4.50
TPSME252010AHR68M	0.68	20	0.045	4.70	4.00
TPSME252010AH1R0M	1.00	20	0.060	3.70	3.50
TPSME252010AH1R5M	1.50	20	0.085	3.00	2.90
TPSME252010AH2R2M	2.20	20	0.110	2.50	2.40
TPSME252010AH4R7M	4.70	20	0.276	1.70	1.35

Remark:

- The part temperature (ambient +temp rise) should not exceed 125°C under the worst case operating conditions. Circuit Design, component placement, PWB trace size and thickness, airflow and other cooling provision all affect the part Temperature. Part temperature should be verified in the application. The rated current as listed is either the saturation current or the heating current depending on which value is lower.

Note TPSME252010 All Series:

- All test data is referenced to 25°C ambient. Test condition: 100KHZ, 0.1Vrms.
- Irms: DC current(A) that will cause an approximate Δt of 40°C.
- Isat: DC current(A) that will cause L0 to drop approximately 30%.
- Operating Temperature Range -55°C to +125°C.



▶ 252012

Electrical Specification (TPSME252012)

Part Number	L (μH)	Tolerance (±%)	DCR (Ω) Max.	IDC Typ. (A)	
				Heat Rating Current DC Amps. Idc (A) L↓30%	Saturation Current DC Amps. Isat (A) L↑40°C
TPSME252012-R47M	0.47	20	0.035	3.80	3.00
TPSME252012-R68M	0.68	20	0.048	3.00	2.50
TPSME252012-1R0M	1.00	20	0.065	2.60	2.43
TPSME252012-1R5M	1.50	20	0.088	1.80	1.95
TPSME252012-2R2M	2.20	20	0.144	1.55	1.70
TPSME252012-3R3M	3.30	20	0.174	1.30	1.35
TPSME252012-4R7M	4.70	20	0.252	1.25	1.12
TPSME252012-6R8M	6.80	20	0.360	0.90	0.85
TPSME252012-100M	10.00	20	0.600	0.75	0.70
TPSME252012-220M	22.00	20	1.150	0.50	0.50

Electrical Specification (TPSME252012 H Series)

Part Number	L (μH)	Tolerance (±%)	DCR (Ω) Max.	IDC Typ. (A)	
				Heat Rating Current DC Amps. Idc (A) L↓30%	Saturation Current DC Amps. Isat (A) L↑40°C
TPSME252012HR33M	0.33	20	0.030	5.05	5.25
TPSME252012HR47M	0.47	20	0.032	4.50	3.75
TPSME252012HR68M	0.68	20	0.042	3.90	3.50
TPSME252012H1R0M	1.00	20	0.056	3.00	3.50
TPSME252012H2R2M	2.20	20	0.100	1.90	2.20
TPSME252012H3R3M	3.30	20	0.144	1.70	1.60
TPSME252012H4R7M	4.70	20	0.216	1.40	1.35
TPSME252012H6R8M	6.80	20	0.300	1.20	1.05
TPSME252012H100M	10.00	20	0.462	1.00	0.90

Electrical Specification (TPSME252012 E Series)

Part Number	L (μH)	Tolerance (±%)	DCR (Ω) Max.	IDC Typ. (A)	
				Heat Rating Current DC Amps. Idc (A) L↓30%	Saturation Current DC Amps. Isat (A) L↑40°C
TPSME252012ER24M	0.24	20	0.025	5.00	4.30
TPSME252012ER47M	0.47	20	0.038	5.00	3.75
TPSME252012ER68M	0.68	20	0.045	4.10	3.60
TPSME252012E1R0M	1.00	20	0.054	3.50	3.50
TPSME252012E1R5M	1.50	20	0.072	2.50	2.25
TPSME252012E2R2M	2.20	20	0.105	2.30	2.40

Electrical Specification (TPSME252012 I Series)

Part Number	L (μH)	Tolerance (±%)	DCR (Ω) Max.	IDC Typ. (A)	
				Heat Rating Current DC Amps. Idc (A) L↓30%	Saturation Current DC Amps. Isat (A) L↑40°C
TPSME252012IR24M	0.24	20	0.025	5.00	4.30
TPSME252012IR47M	0.47	20	0.035	6.00	3.80
TPSME252012IR68M	0.68	20	0.045	4.80	3.80
TPSME252012I1R0M	1.00	20	0.057	4.00	3.60
TPSME252012I1R5M	1.50	20	0.095	4.00	3.00
TPSME252012I2R2M	2.20	20	0.100	3.00	2.40

Remark:

- The part temperature (ambient +temp rise) should not exceed 125°C under the worst case operating conditions. Circuit Design, component placement, PWB trace size and thickness, airflow and other cooling provision all affect the part Temperature. Part temperature should be verified in the application. The rated current as listed is either the saturation current or the heating current depending on which value is lower.

Note TPSME252012 All Series:

- All test data is referenced to 25°C ambient. Test condition: 100KHZ, 0.1Vrms.
- Irms: DC current(A) that will cause an approximate Δt of 40°C.
- Isat: DC current(A) that will cause L0 to drop approximately 30%.
- Operating Temperature Range -55°C to +125°C.



▶ **3010**

Electrical Specification (TPSME3010)

Part Number	L (μH)	Tolerance (±%)	DCR (Ω) Max.	IDC Typ. (A)	
				Heat Rating Current DC Amps. Idc (A) L↓30%	Saturation Current DC Amps. Isat (A) L↑40°C
TPSME3010-R56M	0.56	20	0.048	2.80	2.15
TPSME3010-R68M	0.68	20	0.048	2.50	2.15
TPSME3010-1R0M	1.00	20	0.066	2.15	2.00
TPSME3010-1R5M	1.50	20	0.078	1.65	1.70
TPSME3010-2R2M	2.20	20	0.096	1.35	1.55
TPSME3010-3R3M	3.30	20	0.145	1.20	1.25
TPSME3010-4R7M	4.70	20	0.222	1.10	1.05
TPSME3010-6R8M	6.80	20	0.330	0.85	0.70
TPSME3010-8R2M	8.20	20	0.348	0.80	0.80
TPSME3010-100M	10.00	20	0.480	0.70	0.70
TPSME3010-150M	15.00	20	0.624	0.60	0.60
TPSME3010-220M	22.00	20	1.000	0.50	0.50
TPSME3010-330M	10.00	20	0.480	0.70	0.70

Remark:

- The part temperature (ambient +temp rise) should not exceed 125°C under the worst case operating conditions. Circuit Design, component placement, PWB trace size and thickness, airflow and other cooling provision all affect the part Temperature. Part temperature should be verified in the application. The rated current as listed is either the saturation current or the heating current depending on which value is lower.

Note TPSME3010 All Series:

- All test data is referenced to 25°C ambient. Test condition: 100KHZ, 0.1Vrms.
- Irms: DC current(A) that will cause an approximate Δt of 40°C.
- Isat: DC current(A) that will cause L0 to drop approximately 30%.
- Operating Temperature Range -55°C to +125°C.



▶ 3012

Electrical Specification (TPSME3012)

Part Number	L (μH)	Tolerance (±%)	DCR (Ω) Max.	IDC Typ. (A)	
				Heat Rating Current DC Amps. Idc (A) L↓30%	Saturation Current DC Amps. Isat (A) L↑40°C
TPSME3012-R82M	0.82	20	0.039	2.60	3.30
TPSME3012-1R0M	1.00	20	0.048	2.50	3.30
TPSME3012-1R2M	1.20	20	0.048	2.15	2.60
TPSME3012-1R5M	1.50	20	0.060	2.10	2.30
TPSME3012-2R2M	2.20	20	0.075	1.65	2.10
TPSME3012-3R3M	3.30	20	0.108	1.45	1.70
TPSME3012-4R7M	4.70	20	0.144	1.15	1.50
TPSME3012-6R8M	6.80	20	0.210	1.05	1.15
TPSME3012-100M	10.00	20	0.312	0.75	1.00
TPSME3012-150M	15.00	20	0.420	0.60	0.85
TPSME3012-180M	18.00	20	0.576	0.60	0.78
TPSME3012-220M	22.00	20	0.588	0.50	0.75
TPSME3012-330M	33.00	20	0.960	0.47	0.55
TPSME3012-470M	47.00	20	1.560	0.45	0.45

Electrical Specification (TPSME3012 I Series)

Part Number	L (μH)	Tolerance (±%)	DCR (Ω) Max.	IDC Typ. (A)	
				Heat Rating Current DC Amps. Idc (A) L↓30%	Saturation Current DC Amps. Isat (A) L↑40°C
TPSME3012I1R0M	1.00	20	0.055	6.00	3.10
TPSME3012I2R2M	2.20	20	0.108	3.35	2.35
TPSME3012I4R7M	4.70	20	0.235	2.50	1.50
TPSME3012I100M	10.00	20	0.415	1.10	0.90
TPSME3012I220M	22.00	20	0.800	0.75	0.70

Remark:

- The part temperature (ambient +temp rise) should not exceed 125°C under the worst case operating conditions. Circuit Design, component placement, PWB trace size and thickness, airflow and other cooling provision all affect the part Temperature. Part temperature should be verified in the application. The rated current as listed is either the saturation current or the heating current depending on which value is lower.

Note TPSME3012 All Series:

- All test data is referenced to 25°C ambient. Test condition: 100KHZ, 0.1Vrms.
- Irms: DC current(A) that will cause an approximate Δt of 40°C.
- Isat: DC current(A) that will cause L0 to drop approximately 30%.
- Operating Temperature Range -55°C to +125°C.



▶ 3015

Electrical Specification (TPSME3015)

Part Number	L (μH)	Tolerance (±%)	DCR (Ω) Max.	IDC Typ. (A)	
				Heat Rating Current DC Amps. Idc (A) L↓30%	Saturation Current DC Amps. Isat (A) L↑40°C
TPSME3015-1R0M	1.00	20	0.040	2.80	2.85
TPSME3015-1R2M	1.20	20	0.048	2.80	2.65
TPSME3015-1R5M	1.50	20	0.055	2.75	2.60
TPSME3015-2R2M	2.20	20	0.072	2.10	2.25
TPSME3015-3R3M	3.30	20	0.102	1.75	1.85
TPSME3015-3R9M	3.90	20	0.132	1.50	1.70
TPSME3015-4R7M	4.70	20	0.145	1.45	1.50
TPSME3015-5R6M	5.60	20	0.156	1.20	1.50
TPSME3015-6R8M	6.80	20	0.200	1.15	1.30
TPSME3015-8R2M	8.20	20	0.228	1.05	1.20
TPSME3015-100M	10.00	20	0.300	1.10	1.05
TPSME3015-120M	12.00	20	0.300	0.85	1.05
TPSME3015-150M	15.00	20	0.420	0.80	0.95
TPSME3015-220M	22.00	20	0.545	0.65	0.85
TPSME3015-330M	33.00	20	0.852	0.50	0.65
TPSME3015-470M	47.00	20	1.200	0.45	0.55
TPSME3015-680M	68.00	20	2.400	0.34	0.40

Remark:

- The part temperature (ambient +temp rise) should not exceed 125°C under the worst case operating conditions. Circuit Design, component placement, PWB trace size and thickness, airflow and other cooling provision all affect the part Temperature. Part temperature should be verified in the application. The rated current as listed is either the saturation current or the heating current depending on which value is lower.

Note TPSME3015 All Series:

- All test data is referenced to 25°C ambient. Test condition: 100KHZ, 0.1Vrms.
- Irms: DC current(A) that will cause an approximate Δt of 40°C.
- Isat: DC current(A) that will cause L0 to drop approximately 30%.
- Operating Temperature Range -55°C to +125°C.

▶ 4012

Electrical Specification (TPSME4012)

Part Number	L (μH)	Tolerance (±%)	DCR (Ω) Max.	IDC Typ. (A)	
				Heat Rating Current DC Amps. Idc (A) L↓30%	Saturation Current DC Amps. Isat (A) L↑40°C
TPSME4012-R82M	0.82	20	0.065	3.65	2.20
TPSME4012-1R0M	1.00	20	0.065	3.20	2.20
TPSME4012-1R5M	1.50	20	0.078	2.50	2.00
TPSME4012-2R2M	2.20	20	0.104	2.10	2.10
TPSME4012-3R3M	3.30	20	0.143	1.95	1.70
TPSME4012-4R7M	4.70	20	0.182	1.55	1.50
TPSME4012-5R6M	5.60	20	0.215	1.60	1.35
TPSME4012-6R8M	6.80	20	0.257	1.40	1.30
TPSME4012-100M	10.00	20	0.312	1.05	1.05
TPSME4012-150M	15.00	20	0.494	0.90	0.90
TPSME4012-220M	22.00	20	0.741	0.70	0.75
TPSME4012-470M	47.00	20	1.760	0.45	0.45
TPSME4012-101M	100.00	20	3.600	0.35	0.30

Remark:

- The part temperature (ambient +temp rise) should not exceed 125°C under the worst case operating conditions. Circuit Design, component placement, PWB trace size and thickness, airflow and other cooling provision all affect the part Temperature. Part temperature should be verified in the application. The rated current as listed is either the saturation current or the heating current depending on which value is lower.

Note TPSME4012 All Series:

- All test data is referenced to 25°C ambient. Test condition: 100KHZ, 0.1Vrms.
- Irms: DC current(A) that will cause an approximate Δt of 40°C.
- Isat: DC current(A) that will cause L0 to drop approximately 30%.
- Operating Temperature Range -55°C to +125°C.



▶ 4018

Electrical Specification (TPSME4018)

Part Number	L (μH)	Tolerance (±%)	DCR (Ω) Max.	IDC Typ. (A)	
				Heat Rating Current DC Amps. Idc (A) L↓30%	Saturation Current DC Amps. Isat (A) L↑40°C
TPSME4018-1R0M	1.00	20	0.030	4.85	3.80
TPSME4018-1R2M	1.20	20	0.030	4.80	3.80
TPSME4018-1R5M	1.50	20	0.036	4.25	3.20
TPSME4018-2R2M	2.20	20	0.048	3.40	2.90
TPSME4018-3R3M	3.30	20	0.060	3.00	2.50
TPSME4018-3R9M	3.90	20	0.078	2.80	2.20
TPSME4018-4R7M	4.70	20	0.078	2.30	2.20
TPSME4018-6R8M	6.80	20	0.108	1.85	1.90
TPSME4018-100M	10.00	20	0.168	1.55	1.30
TPSME4018-150M	15.00	20	0.228	1.25	1.20
TPSME4018-220M	22.00	20	0.336	1.10	1.10
TPSME4018-330M	33.00	20	0.480	0.90	0.85
TPSME4018-470M	47.00	20	0.720	0.80	0.70
TPSME4018-101M	100.00	20	1.740	0.55	0.35

Remark:

- The part temperature (ambient +temp rise) should not exceed 125°C under the worst case operating conditions. Circuit Design, component placement, PWB trace size and thickness, airflow and other cooling provision all affect the part Temperature. Part temperature should be verified in the application. The rated current as listed is either the saturation current or the heating current depending on which value is lower.

Note TPSME4018 All Series:

- All test data is referenced to 25°C ambient. Test condition: 100KHZ, 0.1Vrms.
- Irms: DC current(A) that will cause an approximate Δt of 40°C.
- Isat: DC current(A) that will cause L0 to drop approximately 30%.
- Operating Temperature Range -55°C to +125°C.



▶ 4030

Electrical Specification (TPSME4030)

Part Number	L (μH)	Tolerance (±%)	DCR (Ω) Max.	IDC Typ. (A)	
				Heat Rating Current DC Amps. Idc (A) L↓30%	Saturation Current DC Amps. Isat (A) L↑40°C
TPSME4030-R91M	0.91	20	0.029	7.30	3.50
TPSME4030-1R0M	1.00	20	0.034	6.50	3.30
TPSME4030-1R2M	1.20	20	0.038	6.00	3.25
TPSME4030-1R5M	1.50	20	0.039	5.50	3.20
TPSME4030-2R2M	2.20	20	0.046	4.70	2.85
TPSME4030-3R3M	3.30	20	0.052	3.70	2.65
TPSME4030-4R7M	4.70	20	0.078	3.20	2.20
TPSME4030-6R8M	6.80	20	0.109	2.80	1.80
TPSME4030-100M	10.00	20	0.125	2.20	1.65
TPSME4030-120M	12.00	20	0.170	2.10	1.45
TPSME4030-150M	15.00	20	0.245	1.90	1.20
TPSME4030-220M	22.00	20	0.295	1.50	1.10
TPSME4030-330M	33.00	20	0.415	1.30	0.95
TPSME4030-390M	39.00	20	0.450	1.10	0.90
TPSME4030-470M	47.00	20	0.580	1.05	0.80
TPSME4030-560M	56.00	20	0.720	0.95	0.70
TPSME4030-620M	62.00	20	1.080	0.85	0.60
TPSME4030-680M	68.00	20	1.130	0.85	0.55
TPSME4030-101M	100.00	20	1.450	0.75	0.50
TPSME4030-121M	120.00	20	1.630	0.60	0.47
TPSME4030-151M	150.00	20	1.720	0.60	0.46
TPSME4030-331M	330.00	20	4.080	0.38	0.30

Remark:

- The part temperature (ambient +temp rise) should not exceed 125°C under the worst case operating conditions. Circuit Design, component placement, PWB trace size and thickness, airflow and other cooling provision all affect the part Temperature. Part temperature should be verified in the application. The rated current as listed is either the saturation current or the heating current depending on which value is lower.

Note TPSME4030 All Series:

- All test data is referenced to 25°C ambient. Test condition: 100KHZ, 0.1Vrms.
- Irms: DC current(A) that will cause an approximate Δt of 40°C.
- Isat: DC current(A) that will cause L0 to drop approximately 30%.
- Operating Temperature Range -55°C to +125°C.



▶ 5020

Electrical Specification (TPSME5020)

Part Number	L (μH)	Tolerance (±%)	DCR (Ω) Max.	IDC Typ. (A)	
				Heat Rating Current DC Amps. Idc (A) L↓30%	Saturation Current DC Amps. Isat (A) L↑40°C
TPSME5020-R47M	0.47	20	0.017	6.15	4.60
TPSME5020-R75M	0.75	20	0.022	5.50	4.00
TPSME5020-1R0M	1.00	20	0.026	4.10	3.80
TPSME5020-1R2M	1.20	20	0.029	4.50	3.55
TPSME5020-1R5M	1.50	20	0.034	4.10	3.20
TPSME5020-2R2M	2.20	20	0.042	3.20	2.90
TPSME5020-2R7M	2.70	20	0.049	2.90	2.70
TPSME5020-3R0M	3.00	20	0.049	2.55	2.70
TPSME5020-3R3M	3.30	20	0.056	2.55	2.50
TPSME5020-3R6M	3.60	20	0.056	2.80	2.50
TPSME5020-3R9M	3.90	20	0.056	2.30	2.50
TPSME5020-4R3M	4.30	20	0.074	2.50	2.20
TPSME5020-4R7M	4.70	20	0.074	2.50	2.20
TPSME5020-5R1M	5.10	20	0.083	2.25	2.05
TPSME5020-5R6M	5.60	20	0.083	2.30	2.05
TPSME5020-6R8M	6.80	20	0.108	2.05	1.80
TPSME5020-7R5M	7.50	20	0.117	1.85	1.75
TPSME5020-8R2M	8.20	20	0.127	1.85	1.65
TPSME5020-9R1M	9.10	20	0.143	1.70	1.55
TPSME5020-100M	10.00	20	0.143	1.70	1.55
TPSME5020-120M	12.00	20	0.182	1.50	1.40
TPSME5020-150M	15.00	20	0.215	1.35	1.25
TPSME5020-180M	18.00	20	0.260	1.25	1.15
TPSME5020-220M	22.00	20	0.294	1.15	1.10

Remark:

- The part temperature (ambient +temp rise) should not exceed 125°C under the worst case operating conditions. Circuit Design, component placement, PWB trace size and thickness, airflow and other cooling provision all affect the part Temperature. Part temperature should be verified in the application. The rated current as listed is either the saturation current or the heating current depending on which value is lower.

Note TPSME5020 All Series:

- All test data is referenced to 25°C ambient. Test condition: 100KHZ, 0.1Vrms.
- Irms: DC current(A) that will cause an approximate Δt of 40°C.
- Isat: DC current(A) that will cause L0 to drop approximately 30%.
- Operating Temperature Range -55°C to +125°C.



▶ 6020

Electrical Specification (TPSME6020)

Part Number	L (μH)	Tolerance (±%)	DCR (Ω) Max.	IDC Typ. (A)	
				Heat Rating Current DC Amps. Idc (A) L↓30%	Saturation Current DC Amps. Isat (A) L↑40°C
TPSME6020-1R0M	1.0	20	0.028	4.10	3.40
TPSME6020-1R5N	1.5	30	0.028	3.90	3.10
TPSME6020-2R2N	2.2	30	0.047	3.55	2.60
TPSME6020-3R3N	3.3	30	0.061	2.90	2.50
TPSME6020-4R7N	4.7	30	0.078	2.80	1.90
TPSME6020-5R6N	5.6	30	0.094	2.20	1.80
TPSME6020-6R8N	6.80	30	0.114	2.00	1.70
TPSME6020-100M	10	20	0.162	1.55	1.30
TPSME6020-150M	15	20	0.216	1.30	1.10
TPSME6020-220M	22	20	0.324	1.05	0.90
TPSME6020-470M	47	20	0.675	0.80	0.70

Remark:

- The part temperature (ambient +temp rise) should not exceed 125°C under the worst case operating conditions. Circuit Design, component placement, PWB trace size and thickness, airflow and other cooling provision all affect the part Temperature. Part temperature should be verified in the application. The rated current as listed is either the saturation current or the heating current depending on which value is lower.

Note TPSME5020 All Series:

- All test data is referenced to 25°C ambient. Test condition: 100KHZ, 0.1Vrms.
- Irms: DC current(A) that will cause an approximate Δt of 40°C.
- Isat: DC current(A) that will cause L0 to drop approximately 30%.
- Operating Temperature Range -55°C to +125°C.



▶ 6028

Electrical Specification (TPSME6028)

Part Number	L (μH)	Tolerance (±%)	DCR (Ω) Max.	IDC Typ. (A)	
				Heat Rating Current DC Amps. Idc (A) L↓30%	Saturation Current DC Amps. Isat (A) L↑40°C
TPSME6028-1R0N	1.0	30	0.016	6.50	4.50
TPSME6028-1R5N	1.5	30	0.021	5.70	4.20
TPSME6028-2R2N	2.2	30	0.027	4.90	3.60
TPSME6028-3R3M	3.30	20	0.034	3.50	3.30
TPSME6028-4R7M	4.70	20	0.045	2.90	2.70
TPSME6028-5R6M	5.60	20	0.060	2.70	2.40
TPSME6028-6R8M	6.80	20	0.076	2.60	2.30
TPSME6028-8R2M	8.20	20	0.092	2.30	2.10
TPSME6028-100M	10.0	20	0.099	1.90	1.70
TPSME6028-120M	12.0	20	0.119	1.70	1.50
TPSME6028-150M	15.0	20	0.168	1.60	1.40
TPSME6028-180M	18.0	20	0.175	1.40	1.20
TPSME6028-220M	22.0	20	0.189	1.30	1.10
TPSME6028-270M	27.0	20	0.243	1.20	1.05
TPSME6028-330M	33.0	20	0.297	1.10	1.00
TPSME6028-470M	47.0	20	0.378	1.00	0.80
TPSME6028-680M	68.0	20	0.607	0.80	0.70
TPSME6028-820M	82.0	20	0.702	0.70	0.60
TPSME6028-101M	100.0	20	0.887	0.50	0.50

Remark:

- The part temperature (ambient +temp rise) should not exceed 125°C under the worst case operating conditions. Circuit Design, component placement, PWB trace size and thickness, airflow and other cooling provision all affect the part Temperature. Part temperature should be verified in the application. The rated current as listed is either the saturation current or the heating current depending on which value is lower.

Note TPSME5020 All Series:

- All test data is referenced to 25°C ambient. Test condition: 100KHZ, 0.1Vrms.
- Irms: DC current(A) that will cause an approximate Δt of 40°C.
- Isat: DC current(A) that will cause L0 to drop approximately 30%.
- Operating Temperature Range -55°C to +125°C.



▶ 6045

Electrical Specification (TPSME6045)

Part Number	L (μH)	Tolerance (±%)	DCR (Ω) Max.	IDC Typ. (A)	
				Heat Rating Current DC Amps. Idc (A) L↓30%	Saturation Current DC Amps. Isat (A) L↑40°C
TPSME6045-1R0M	1.00	20	0.010	15.00	6.35
TPSME6045-1R2M	1.20	20	0.013	12.50	6.05
TPSME6045-1R5M	1.50	20	0.013	11.50	6.05
TPSME6045-2R2M	2.20	20	0.018	10.50	5.00
TPSME6045-3R3M	3.30	20	0.024	9.00	4.40
TPSME6045-4R7M	4.70	20	0.026	7.50	4.20
TPSME6045-6R8M	6.80	20	0.040	6.20	3.30
TPSME6045-100M	10.00	20	0.056	4.80	3.00
TPSME6045-120M	12.00	20	0.065	4.50	2.75
TPSME6045-150M	15.00	20	0.085	3.80	2.30
TPSME6045-220M	22.00	20	0.116	3.50	2.00
TPSME6045-330M	33.00	20	0.175	2.60	1.60
TPSME6045-470M	47.00	20	0.260	2.30	1.30
TPSME6045-560M	56.00	20	0.286	1.90	1.25
TPSME6045-680M	68.00	20	0.325	1.80	1.20
TPSME6045-101M	100.00	20	0.468	1.40	1.10

Remark:

- The part temperature (ambient +temp rise) should not exceed 125°C under the worst case operating conditions. Circuit Design, component placement, PWB trace size and thickness, airflow and other cooling provision all affect the part Temperature. Part temperature should be verified in the application. The rated current as listed is either the saturation current or the heating current depending on which value is lower.

Note TPSME6045 All Series:

- All test data is referenced to 25°C ambient. Test condition: 100KHZ, 0.1Vrms.
- Irms: DC current(A) that will cause an approximate Δt of 40°C.
- Isat: DC current(A) that will cause L0 to drop approximately 30%.
- Operating Temperature Range -55°C to +125°C.



▶ 8040

Electrical Specification (TPSME8040)

Part Number	L (μH)	Tolerance (±%)	DCR (Ω) Max.	IDC Typ. (A)	
				Heat Rating Current DC Amps. Idc (A) L↓30%	Saturation Current DC Amps. Isat (A) L↑40°C
TPSME8040-0R9M	0.9	30	0.008	11.0	7.8
TPSME8040-1R4M	1.4	30	0.010	9.0	7.0
TPSME8040-2R0M	2.0	30	0.012	7.4	6.3
TPSME8040-3R6M	3.6	30	0.020	5.3	4.9
TPSME8040-4R7M	4.7	30	0.024	4.7	4.1
TPSME8040-6R8M	6.8	30	0.033	4.0	3.7
TPSME8040-100M	10.0	20	45	3.4	3.1
TPSME8040-150M	15.0	20	0.065	2.7	2.4
TPSME8040-220M	22.0	20	0.086	2.2	2.2
TPSME8040-330M	33.0	20	0.130	1.9	1.7
TPSME8040-470M	47.0	20	0.195	1.5	1.4
TPSME8040-680M	68.0	20	0.299	1.2	1.1
TPSME8040-101M	100.0	20	0.377	1.0	1.0

Remark:

- The part temperature (ambient +temp rise) should not exceed 125°C under the worst case operating conditions. Circuit Design, component placement, PWB trace size and thickness, airflow and other cooling provision all affect the part Temperature. Part temperature should be verified in the application. The rated current as listed is either the saturation current or the heating current depending on which value is lower.

Note TPSME8040 All Series:

- All test data is referenced to 25°C ambient. Test condition: 100KHZ, 0.1Vrms.
- Irms: DC current(A) that will cause an approximate Δt of 40°C.
- Isat: DC current(A) that will cause L0 to drop approximately 30%.
- Operating Temperature Range -55°C to +125°C.



▶ **Order Codes**

Order Codes (TPSME)

TPSME	3010		-	R10		M	
Part Number	Dimensions (L×M)(mm)			Inductance		Tolerance	
TPSME	201610	2.0×1.6		R24	0.24μH	J	± 5%
	252010	2.5×2.0		1R0	1.00μH	K	± 10%
	252012	2.5×2.0		100	10.00μH	L	± 15%
	3010	3.0×3.0		101	100.00μH	M	± 20%
	3012	3.0×3.0				P	± 25%
	3015	3.0×3.0				N	± 30%
	4012	4.0×4.0					
	4018	4.0×4.0					
	4030	4.0×4.0					
	5020	5.0×5.0					
	5040	5.0×5.0					
	6020	6.0×6.0					
	6028	6.0×6.0					
	6045	6.0×6.0					
	8040	8.0×8.0					

► General Information

How to Quickly Search Inductor for all of the Characteristics?

Quickly Search Inductor Finder

Searching and comparing data sheets of inductor manufacturers can be time consuming. Token's Parameter Sorting Search Mode allows selection of inductors based on different parameters.

By entering just the inductance value,

By sorting parameter to narrow down searching range,

Or by enter keyword / part number / size dimensions L*W*H to partial or exact searching.

Leading-Edge Technology

Token Electronics brand passive component specializes in standard and custom solutions offering the latest in state-of-the-art low profile high power density inductor components. Token provides cost-effective, comprehensive solutions that meet the evolving needs of technology-driven markets. In working closely with the industry leaders in chipset and core development, we remain at the forefront of innovation and new technology to deliver the optimal mix of packaging, high efficiency and unbeatable reliability. Our designs utilize high frequency, low core loss materials, new and custom core shapes in combination with innovative construction and packaging to provide designers with the highest performance parts available on the market.

Find Inductor Solutions Faster

Find Your Inductor - rfq@token.com.tw

Only timely and accurate information can help manage the changing needs of your customers. The Token Inductor Finder puts you only a click away from all of the inductor information you need.

Find Your Solution - rfq@token.com.tw

Selecting the correct inductor solution will not only save you time, but it will give you a competitive edge. At Token, we are committed to helping you find the most efficient alternative for your power design. Our inductor and power supply design experts can help you make that selection.

Please forward us:

- A brief description of your particular application's requirements.
- Details of an existing solution that you'd like to replace, enhance or find an alternative.
- Inquiries for feasibility to tailor a power transformer or inductor to your specific application.

We can also help you with any additional technical information you might need relating to any of our products.

Ask Us Today

