



# 諧振器濾波器 帶裝尺寸

[Web: www.token.com.tw](http://www.token.com.tw)

<mailto:rfq@token.com.tw>

## 德鍵電子工業股份有限公司

台灣： 台灣省新北市五股區中興路一段 137 號  
電話： +886 2981 0109 傳真： +886 2988 7487

大陸： 廣東省深圳市南山區創業路中興工業城綜合樓 12 樓  
電話： +86 755 26055363; 傳真： +86 755 26055365



## ▶ 徑向編帶尺寸

### 陶瓷諧振器濾波器徑向編帶尺寸

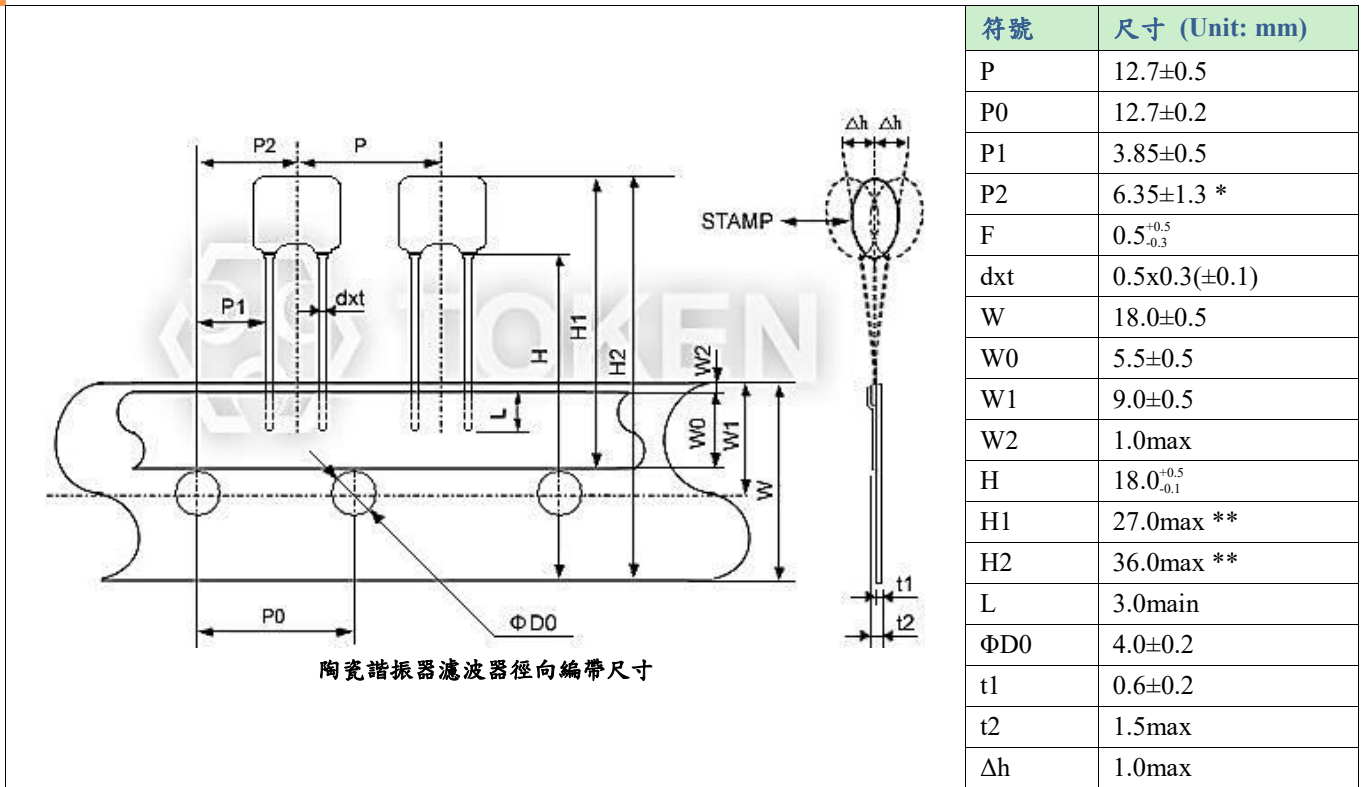

- Notes:
- \* Include the slant of products.
- \*\* Varies with part number.

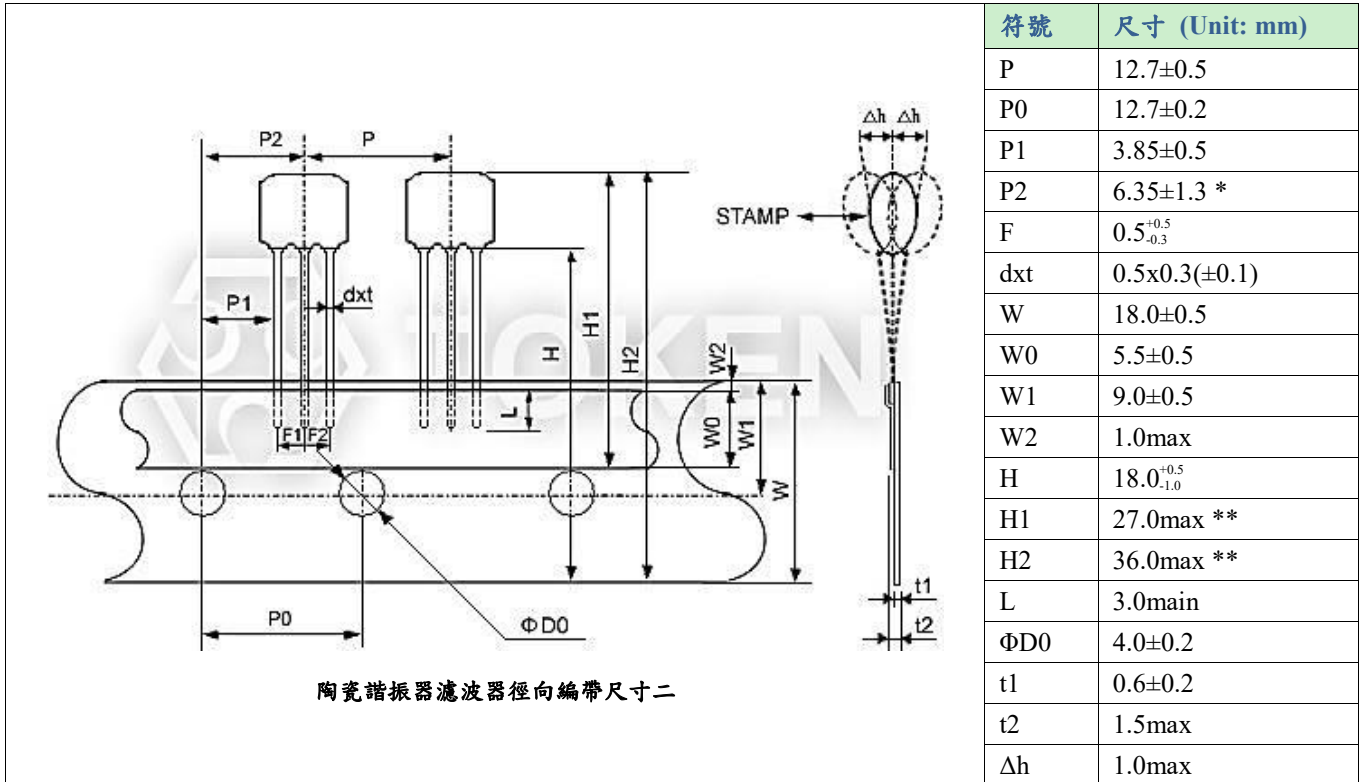

- Notes:
- \* Include the slant of products.
- \*\* Varies with part number.

## ▶ 編帶包裝方法

### 陶瓷諧振器濾波器編帶包裝方法

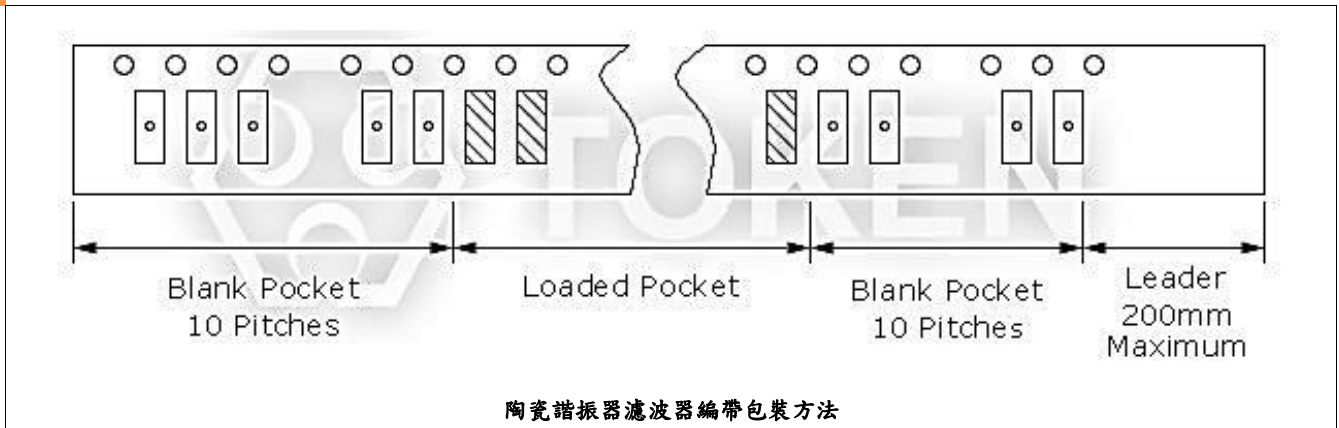

### 編帶盤尺寸(單位：mm)

ΦA	ΦB	W	T	數量每卷	載帶尺寸
179±2	60 typ	8.4 min	14.0max	3000typ	8
179±2	60 typ	12.4 min	19.4max	3000typ	12
179±2	60 typ	12.4 min	19.4max	1000typ	12
179±2	60 typ	16.4 min	22.4max	1000typ	16
330±3	80 min	12.4 min	19.4max	4000typ	12
330±3	80 min	16.4 min	22.4max	4000typ	16

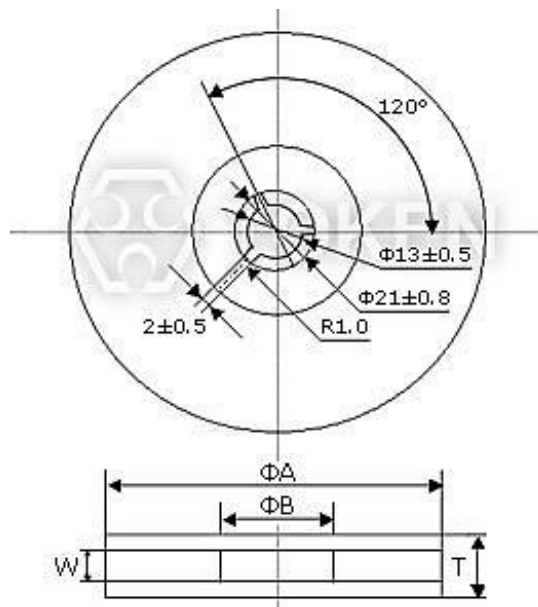

陶瓷諧振器濾波器編帶盤尺寸

## 編帶尺寸(單位：mm)

Code Tolerance Part Num.	A ±0.2	B ±0.2	C ±0.3	D ±0.1	E ±0.1	F ±0.1	G ±0.1	H ±0.1	ΦJ ±0.1	ΦN ±0.1	M max	R max	K ±0.2	T ±0.1
ZTACC MG ZTCC MG	3.8	7.8	16.0	7.5	1.75	8.0	4.0	2.0	1.5	1.6	10°	0.3	2.1	0.3
ZTACR MG ZTTCR MG	2.2	4.7	12.0	5.5	1.75	4.0	4.0	2.0	1.6	1.6	3°	0.3	1.3	0.3
ZTACS MT/MX ZTTCS MT/MX	5.0	4.4	12.0	5.5	1.75	8.0	4.0	2.0	1.5	1.6	10°	0.3	1.8	0.3
ZTACV MT/MX ZTTCV MT/MX	3.4	4.0	12.0	5.5	1.75	8.0	4.0	2.0	1.5	1.6	10°	0.3	1.3	0.3
ZTACW MX ZTTCW MX	2.2	2.8	8.0	3.5	1.75	4.0	4.0	2.0	1.6	1.1	3°	0.3	1.3	0.2

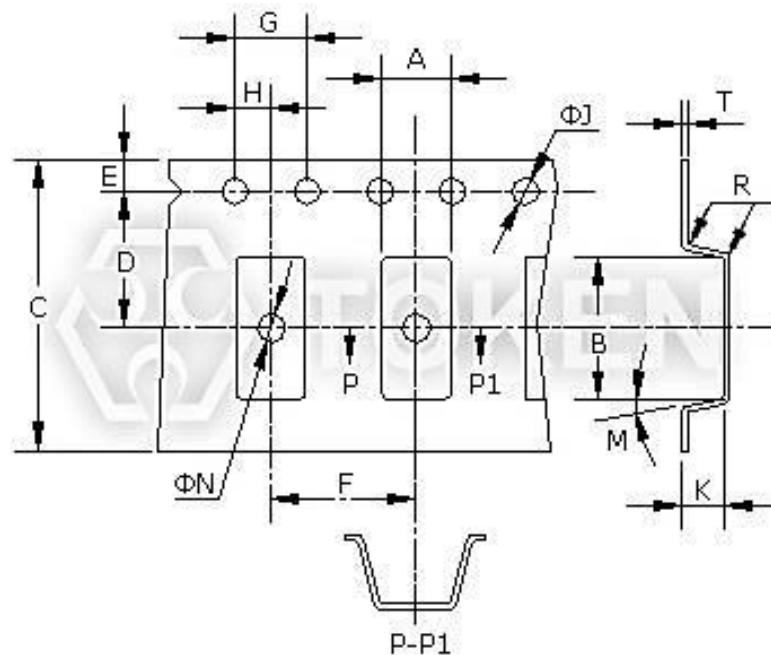

陶瓷諧振器濾波器編帶尺寸

▶ 測試條件及焊接條件

剝離強度測試條件

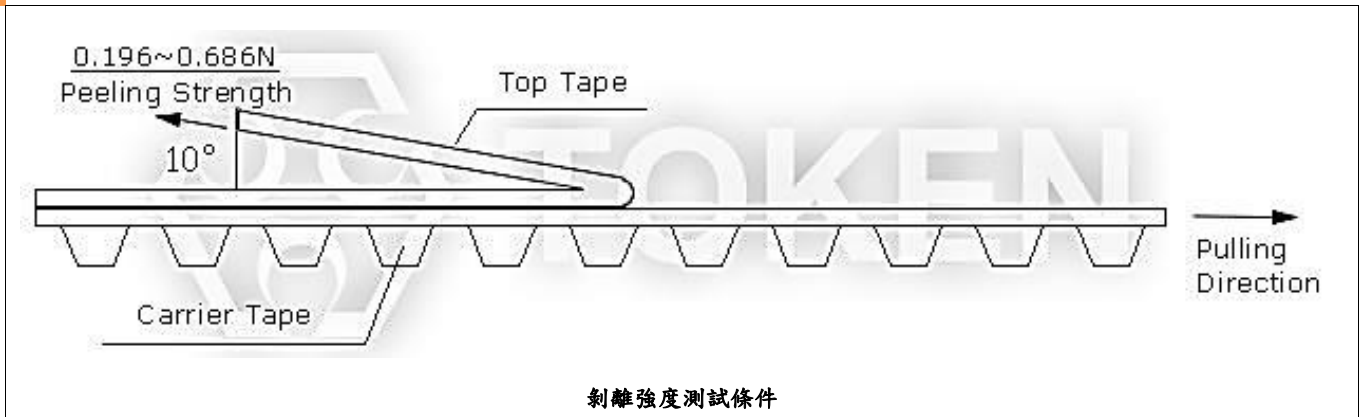

推薦使用再流焊，焊接條件

