

Version:
July 21, 2017



Ceramic Filter Series

Token Electronics Industry Co., Ltd.

Taiwan: No.137, Sec. 1, Zhongxing Rd., Wugu District,
New Taipei City, Taiwan, R.O.C. 24872
Tel: +886 2981 0109 Fax: +886 2988 7487

China: 12F, Zhong Xing Industry Bld., Chuang Ye Road,
Nan Shan District, Shen Zhen City,
Guang Dong, China 518054
Tel: +86 755 26055363; Fax: +86 755 26055365

[Web: www.token.com.tw](http://www.token.com.tw)

[Email: rfq@token.com.tw](mailto:rfq@token.com.tw)

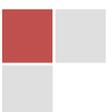

Production Index

Ceramic Filter Series

Filter Terminologies	1
Filter Terminologies	1
Ceramic Filters (LTA)	3
Product Introduction.....	3
Dimensions	4
Technical Characteristics	5
Test Circuit.....	6
Order Codes	6
General Information	7
Ceramic Filters (LT10.7M).....	8
Product Introduction.....	8
Dimensions	9
Technical Characteristics	10
Test Circuit.....	11
Standard Marking Color	11
Order Codes	12
General Information	13
Communication Ceramic Filters (LT 455/450 U/W)	14
Product Introduction.....	14
Dimensions	15
Technical Characteristics	16
Test Circuit.....	17
Order Codes	17
General Information	18
Ceramic Filters (LTB)	19
Product Introduction.....	19
Dimensions	20
Technical Characteristics	21
Test Circuit.....	22
Order Codes	22
General Information	23
Communication Ceramic Chip Filters (LTC455/450 U/W).....	24
Product Introduction.....	24
Dimensions	25
Technical Characteristics	26
Test Circuit.....	27
Order Codes	27
General Information	28
SMD Ceramic Filters (LTCA/CV10.7M).....	29
Product Introduction.....	29
Dimensions	30
Technical Characteristics	31
Order Codes	31
General Information	32



Ceramic Chip Filters (LTCS10.7M).....	33
Product Introduction.....	33
Dimensions.....	34
Technical Characteristics.....	34
Test Circuit.....	35
Order Codes.....	35
General Information.....	36
Communication Ceramic Filters (LTM 455/450 U/W).....	37
Product Introduction.....	37
Dimensions.....	38
Technical Characteristics.....	39
Test Circuit.....	40
Order Codes.....	40
General Information.....	41
Ceramic Filters (LT MB).....	42
Product Introduction.....	42
Dimensions.....	43
Technical Characteristics.....	44
Test Circuit.....	45
Order Codes.....	45
General Information.....	46
Ceramic Filters (LTP).....	47
Product Introduction.....	47
Dimensions.....	48
Technical Characteristics.....	49
Recommended IFT.....	50
Test Circuit.....	50
Order Codes.....	50
General Information.....	51
Ceramic Filters (LTS MCB/MDB).....	52
Product Introduction.....	52
Dimensions.....	53
Technical Characteristics.....	54
Test Circuit.....	55
Order Codes.....	55
General Information.....	56
High-Selectivity Band-Pass Filters (LTT MA).....	57
Product Introduction.....	57
Dimensions.....	58
Technical Characteristics.....	59
Test Circuit.....	60
Order Codes.....	60
General Information.....	61
Ceramic Filters (LTZ).....	62
Product Introduction.....	62
Dimensions.....	63
Technical Characteristics.....	63



Test Circuit.....	64
Recommended IFT.....	64
Order Codes.....	64
General Information.....	65
Narrow Bandwidth Filters (LZU).....	66
Product Introduction.....	66
Dimensions.....	67
Technical Characteristics.....	67
Technical Test Circuit.....	68
Order Codes.....	68
General Information.....	69
Ceramic Miniature Filter (MLT).....	70
Product Introduction.....	70
Dimensions.....	71
Technical Characteristics.....	71
Recommended IFT.....	72
Order Codes.....	72
General Information.....	73

Filter Terminologies

► Filter Terminologies

Characteristics and Properties of Filter Terminologies

What is "Ceramic Filter"?

A filter which uses a piezoelectric ceramics as an electrical-mechanical transducer and as a mechanical resonator. It provides simultaneously the electrical and the mechanical system within a single element.

Filter Characteristic Properties

Center Frequency (Symbol: f_0 ; Unit: Hz)

It signifies the frequency in the center of the pass band width. However, the center frequency for some product is expressed at the point where the loss is minimum.

Pass Band Width (Symbol: PBW; Unit: Hz)

Signifies a difference between the two frequencies where the attenuation becomes 3dB from the level of the minimum loss point.

Insertion Loss (Symbol: IL; Unit: dB)

Expressed in the input and output level ratio at the point of minimum loss in dB. The insertion loss for some product is expressed in the input and output level ratio at the center frequency.

Ripple (Unit: dB)

If there are peaks and valleys in a pass band width, the ripple expressed the level difference of voltage between the maximum peak and minimum valley and it is expressed in dB.

Attenuation Band Width (Symbol: ABW; Unit: Hz)

Signifies a difference between the two frequencies where the attenuation becomes the specified values (dB) from the level of minimum loss.

(Example: Expressed at a point where the attenuation becomes 20 dB in case of 10.7 MHz filter.)

Selectivity (Unit: dB)

Expressed as the attenuation of the detuning point from the center frequency.

(Example: The attenuation that ± 9 kHz was detuned from the center frequency in case of 455 kHz filter.)

Spurious Response (Symbol: sp; Unit: dB)

Expressed as the difference of voltage ratio between minimum attenuation point in the stop band range and minimum loss point in the pass band width by using dB (The stopped range is specified with each filter).

Spurious

Signifies the frequency response based on the parasitic (unwanted) vibration against the frequency except the fundamental vibration.

Bottom Level (Unit: dB)

Signifies the minimum or average attenuation without both main response and spurious within the specified frequency range.



Input/Output Impedance (Unit: Ω)

Signifies the internal impedance value of the input and output side at the center frequency of ceramic piezoelectricity, and it is expressed in Ω . It causes no problem even if the input and the output are used in reverse with ceramic piezoelectricity, since the input and the output impedance are in symmetry of substantially almost same value.

Impedance Matching

When connecting one electric circuit to another, or a component to another, or one electric circuit to a component, the electric energy is supplied most efficiently from the signal source to the load if the signal source impedance and the load impedance are same.

If these impedances are mismatched, electric energy escapes in form of a reflection. To match the signal source impedance and the load impedance is called the impedance matching. This is very important for ceramic piezoelectricity, as an improper impedance matching may cause various troubles.

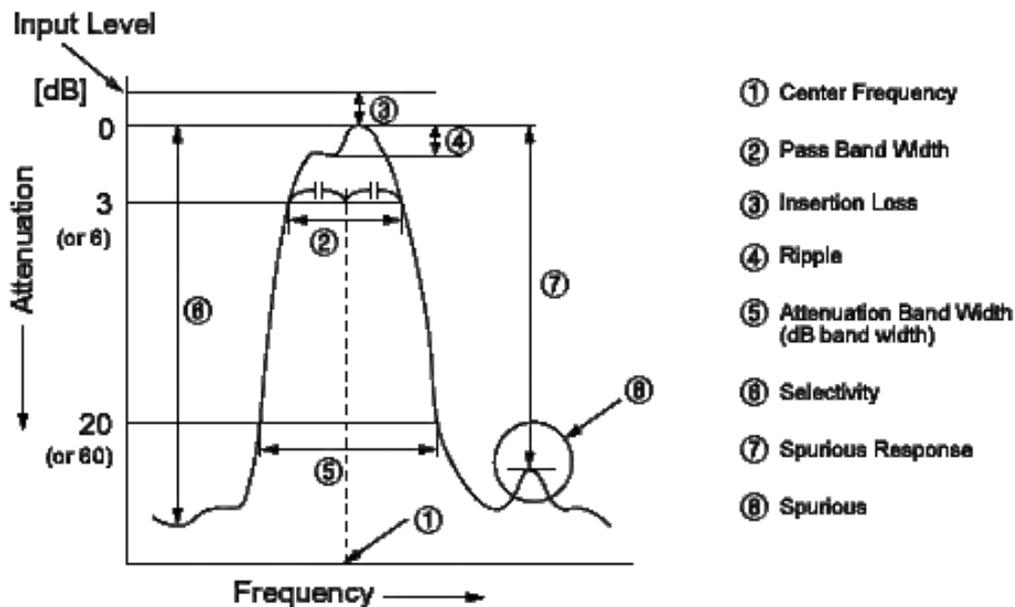

An example of filter Frequency characteristic

Ceramic Filters (LTA)

▶ Product Introduction

Introduction (LTA)

Token ceramic filters for radio-cassette recorder (LTA) series are designed to address the needs of standard radio cassette recorder requirements.

Recommend for use in low cost products where economically, efficient designs are critical. The nominal frequency tolerance is $\pm 2\text{KHz}$.

Token ceramic (LTA) filters conform to the RoHS directive.

Ceramic (LTA) filter for radio cassette recorder can be customized designs and tighter tolerances available on request.

Application of specific designs also available including different piezo band-pass devices and Q specifications adjusted to frequency requirements.

Contact us with your specific needs. For more information, please link to Token official website "[Ceramic Filters](#)".



► Dimensions

Dimensions (Unit: mm) (LTA)

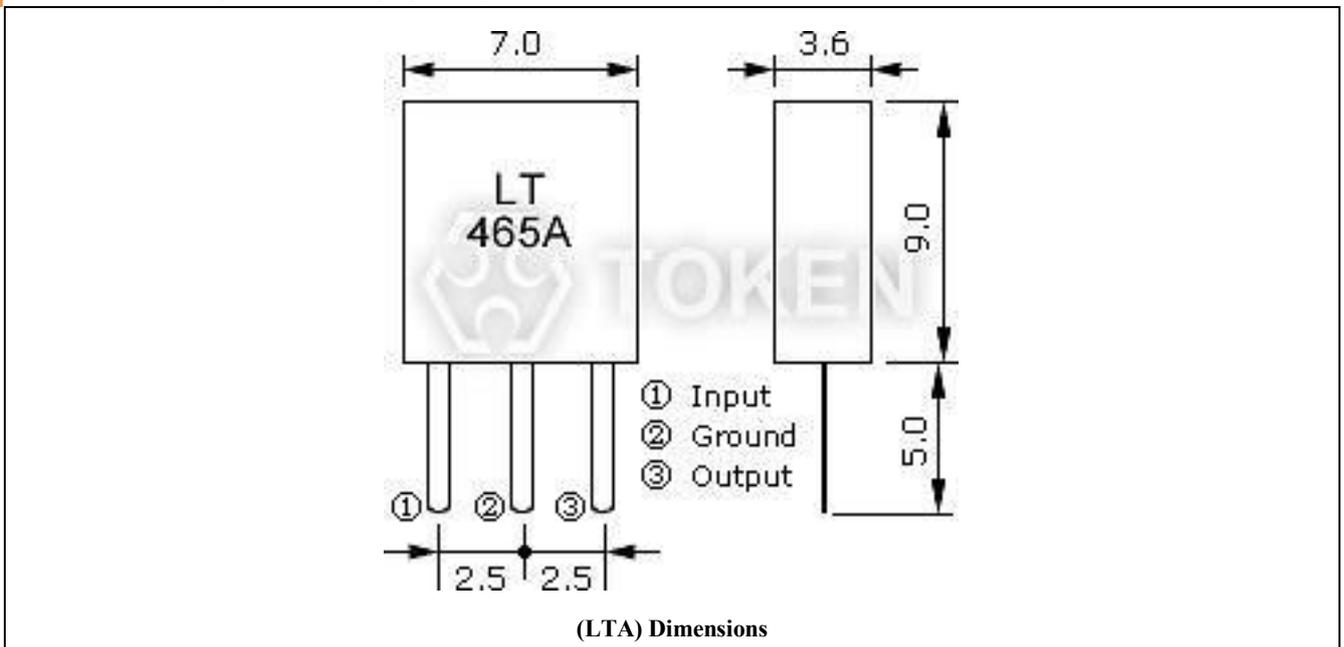

► Technical Characteristics

Technical Characteristics (LT)

Part Number	Center Frequency (fo)(kHz)	Insertion Loss (dB)max	6dB Band Width (kHz)min	Spurious Attenuation (fo±100kHz)(dB)min	Selectivity ±9kHz off (dB)min	Pass Band Ripple (dB)max	Input/Output Impedance (Ω)
LT450A	450±2	3	8	12	11	1	2
LT455A	455±2	3	8	12	11	1	2
LT465A	465±2	3	8	12	11	1	2

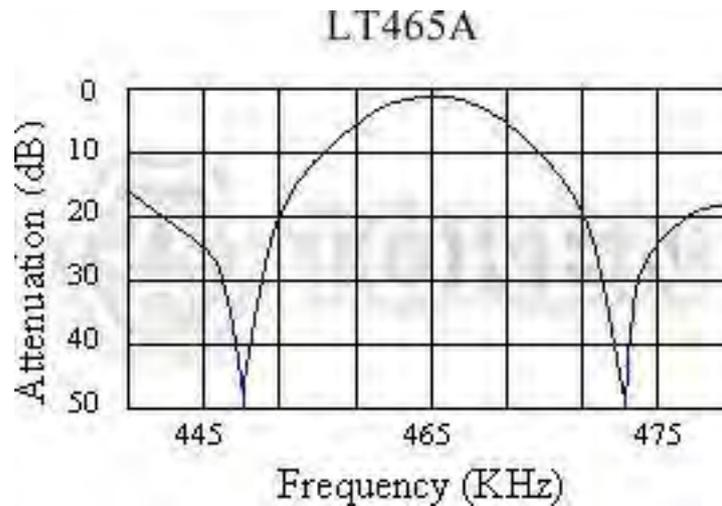

- Center Frequency (fo) is available in a range of 450kHz ~ 470kHz.
The nominal frequency tolerance is ± 2kHz.

▶ Test Circuit

Test Circuit (LT)

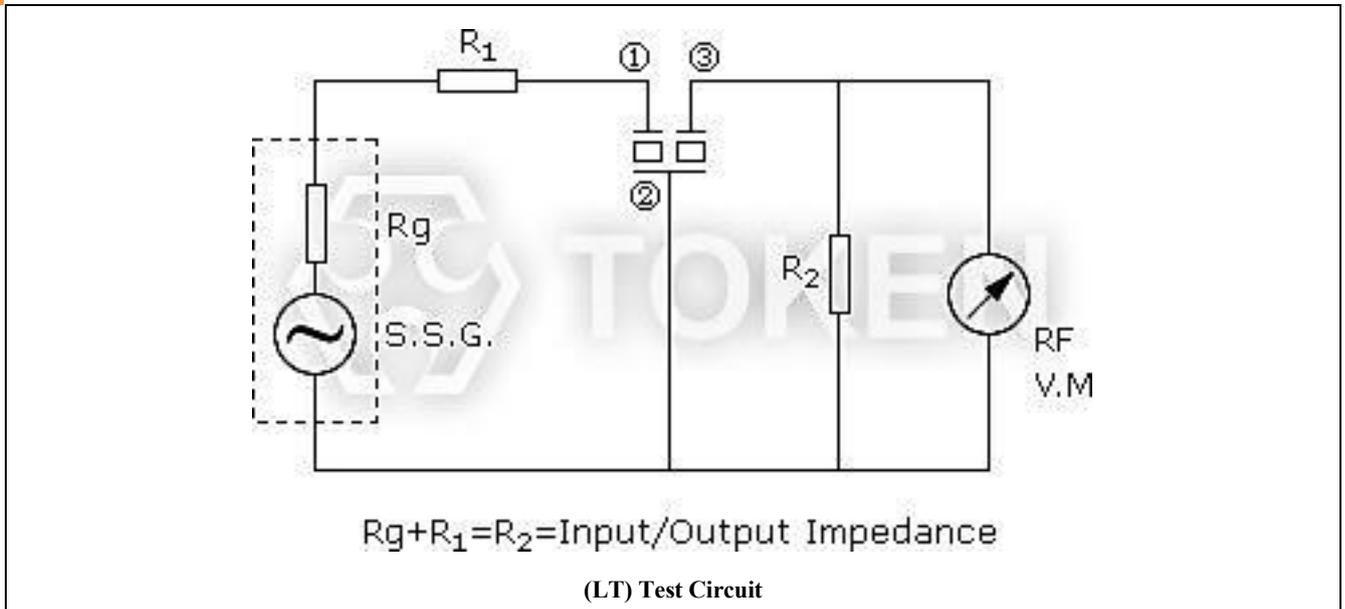

▶ Order Codes

Order Codes (LT)

LT455A	P
Part Number	Package

▶ General Information

Introduction of Filters

For more than two decades, piezo technology has been instrumental in the proliferation of solid state electronics. A view of the future reveals that even greater expectations will be placed on piezoelectric material in the area of new applications and for more stringent performance criteria in modern products.

Token sophisticated ceramics technology has greatly increased selectivity and wide-band characteristics, and has stabilized the characteristics of ceramic filters. The series covers a wide range of attenuation and bandwidths to allow selection of the most optimum filter characteristics for each application.

Token filters are band pass filters consisting of one or more ceramic resonators connected in a ladder network configuration. Pass band characteristics are determined by the relative resonant and anti-resonant frequencies of the resonators. Both narrow and wide pass band configurations are manufactured by adjusting the resonator frequency characteristics.

The IC (Integrated Circuit) has found wide use in the field of commercial equipment, such as automotive radios, stereo systems, 2-way communications, TV sets, etc. Thus, new miniature integrated filters, with high performance, are extremely desirable for use in IF circuits.

Furthermore, radio wave disturbance due to rapid progress of data transmitting rate and remarkable sophistication of communication network have become significant traffic conflicts. Accordingly, the demand for filters with high selectivity and wide pass band width has boosted.

The IC application of the active elements will continue its progress, and there will be a growing demand for highly selective, non-adjustable, miniature and wide pass band width IF circuit.

Advantage of Token Piezoelectric Filters

Token Electronics had been able to develop specialized piezo materials which when combined with an advance design have resulted in a complete line of practical, inexpensive piezo devices for entertainment and communications applications.

Token reliably deliver high-quality components according to the each customer special needs with respect to performance, costs, and technology modifications.

For marketing discontinuations or sourcing activities concerning Piezoelectric Filter products, you are encouraged to contact our Sales Department so the request can be properly directed within Token.



Ceramic Filters (LT10.7M)

► Product Introduction

Token (LT10.7M) ceramic filters are compatible with Murata SFELF10M7.

Features :

- Change in center frequency is typically within $\pm 30\text{ppm}/^\circ\text{C}$ at -20°C to $+80^\circ\text{C}$.
- Various band widths are available for applications in wide to narrow bands.
- Low loss, favorable waveform symmetry, and high selectivity.
- These miniature filters have high mechanical strength.
- Excellent shape factor of frequency response.
- Small dispersion and stable characteristics.
- Good waveform symmetry.
- High reliability.

Token LT10.7M series are monolithic devices which utilize the energy-trapped thickness vibration-mode. This principle of operation is based upon the fact that an excellent resonating element with low spurious vibration can be obtained by adhering to certain theoretical parameters of design. These parameters include the physical dimensions of the peizo element, the electrode pattern, and the associated mass loading effect of the electrodes.



Token categorizes the LT 10.7 family according to rank of center frequency. This ranking indicates that a given LT 10.7 will be marked with one of the colors listed in the following chart and will exhibit the center frequency in Technical Characteristics Table.

The (LT10.7M) offers three series: LT10.7M for FM Receiver (Compatible Murata SFELF10M7), LT10.7M A10 Insertion Loss $2.5\pm 2.0\text{ dB} \sim 4.5\pm 2.0\text{ dB}$ (Compatible Murata SFELF10M7 A10), and LT10.7M Wide Band-width 950 kHz at 20dB/Narrow Band-width 95 kHz at 20dB (Compatible Murata Filter SFELF10M7 DBS Receiver).

(LT10.7M) Narrow Band-width series features stable low spurious and temperature characteristics. This series is suitable for European car-audio or AM up conversion use that needs narrow band characteristics are stable. LT10.7M Wide Band-width series are specified to make up conventional ceramic filters which wider band characteristics not obtained.

Custom parts are available on request. Token will also produce devices outside these specifications to meet specific customer requirements, please contact our sales or link to Token official website "[Ceramic Filters](#)" for more information.



► Dimensions

Dimensions (Unit: mm) (LT10.7M)

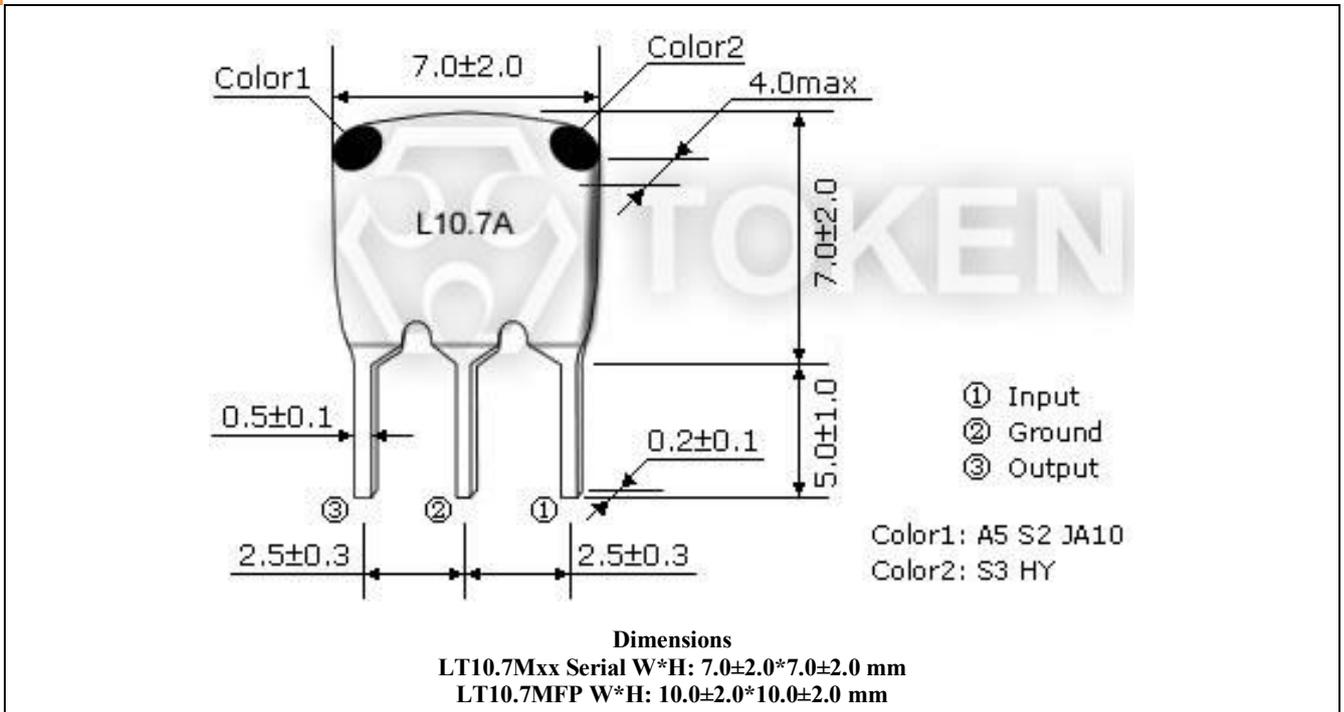

► Technical Characteristics

(LT10.7M) For FM Receiver (Murata SFE10M7 FM-IF Compatible)

Part Number	3dB Band Width (kHz)	20dB Band Width (kHz) max	Insertion Loss (dB) max	Spurious Attenuation (9-12MHz)(dB)min
LT10.7MA5	280±50	650	6	30
LT10.7MS2	230±50	600	6	40
LT10.7MS3	180±40	520	7	40

- Input/Ouput Impedance: 330Ω

(LT10.7M A10) Low Insertion Loss (Murata SFE10M7 A10 Compatible)

Part Number	3dB Band Width (kHz)	20dB Band Width (kHz) max	Insertion Loss (dB)	Spurious Attenuation (9-12MHz)(dB)min
LT10.7MA5A10	280±50	590	2.5±2.0	30
LT10.7MS2A10	230±50	520	3.0±2.0	35
LT10.7MS3A10	180±40	470	3.5±1.5	35
LT10.7MJA10	150±40	360	4.5±2.0	35

- Input/Ouput Impedance: 330Ω

(LT10.7M) Wide/Narrow Band-width (Murata SFE10M7 DBS Receiver Compatible)

Part Number	3dB Band Width (kHz)	20dB Band Width (kHz) max	Insertion Loss (dB)	Spurious Attenuation (9-12MHz)(dB)min
LT10.7MA19	350min	950	3.0±2.0	20
LT10.7MA20	330±50	680	4.0±2.0	30
LT10.7MHY	110±30	350	7.0±2.0	30
LT10.7MFP	20min	95	6.0max	24(10.7±1.0MHz)

- Input/Ouput Impedance: 470Ω(MA19), 330Ω(MA20,MHY), 600Ω(MFP)

Characteristics (LT10.7M)

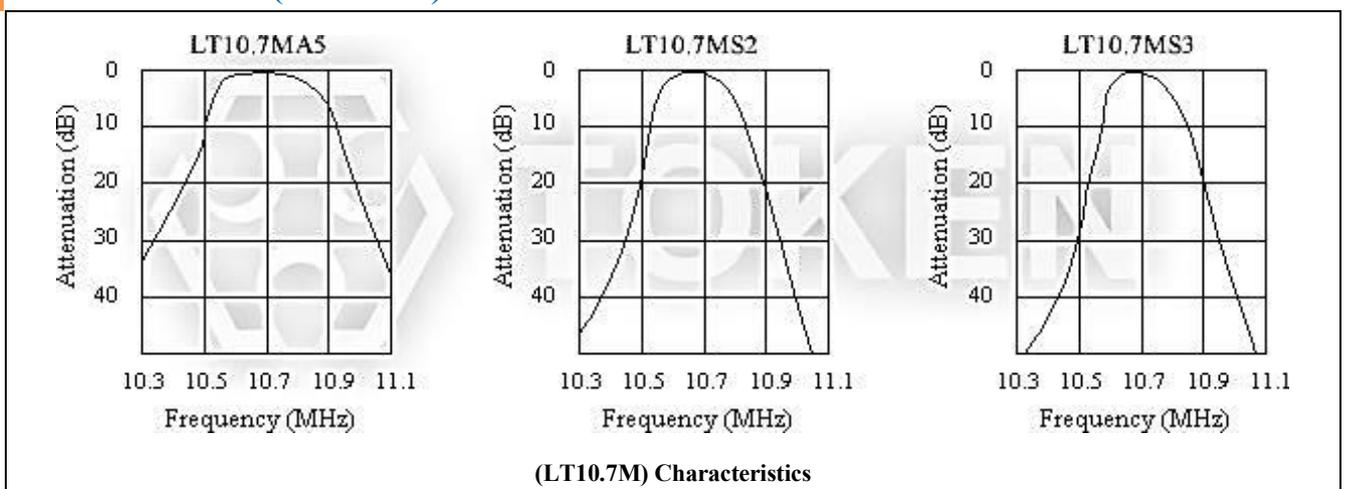

▶ Test Circuit

Matching Conditions & Test Circuit (LT10.7M)

- When using filters, it is most important to match the input/output load to impedance 330 ohm (LT10.7MA19 is 470 ohm matching). Waveform symmetry is damaged when reactance is added to the input/output load.
- Two filters directly connected can be used for high selectivity. For reducing waveform variation, it is recommended to input a buffer AMP between filters.
- The LT10.7M series are of input/output symmetric structure so that in theory there is no input/output directionality. Actual circuits may use different input/output loading conditions (for example, mismatched impedance) or capacitance load. In such cases, the waveform will be a little changed by the direction of the input/output of the filter.

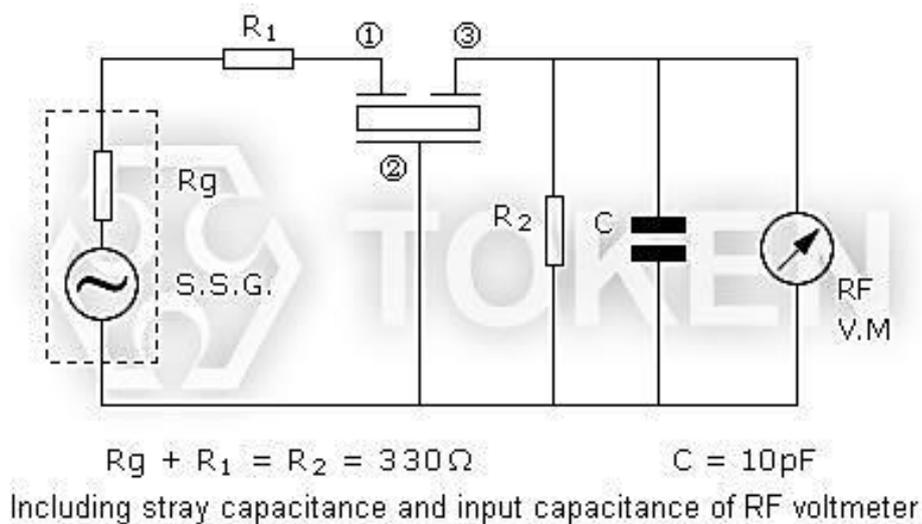

(LT10.7M) Test Circuit

▶ Standard Marking Color

Standard Marking Color (LT10.7M)

Center Frequency	Color
D:10.64MHz±30kHz	Black
B:10.67MHz±30kHz	Blue
A:10.70MHz±30kHz	Red
C:10.73MHz±30kHz	Orange
E:10.76MHz±30kHz	White

Order Codes

Order Codes (LT10.7M)

LT10.7MA5	-	A	P
Part Number		Center Frequency color code	Package
LT10.7MA5		A 10.70MHz±30kHz Red	P Bulks
LT10.7MS2		B 10.67MHz±30kHz Blue	TB Tab Box
LT10.7MS3		C 10.73MHz±30kHz Orange	
LT10.7MA5A10		D 10.64MHz±30kHz Black	
LT10.7MS2A10		E 10.76MHz±30kHz White	
LT10.7MS3A10			
LT10.7MJA10			
LT10.7MA19			
LT10.7MA20			
LT10.7MHY			
LT10.7MFP			

▶ General Information

Introduction of Filters

For more than two decades, piezo technology has been instrumental in the proliferation of solid state electronics. A view of the future reveals that even greater expectations will be placed on piezoelectric material in the area of new applications and for more stringent performance criteria in modern products.

Token sophisticated ceramics technology has greatly increased selectivity and wide-band characteristics, and has stabilized the characteristics of ceramic filters. The series covers a wide range of attenuation and bandwidths to allow selection of the most optimum filter characteristics for each application.

Token filters are band pass filters consisting of one or more ceramic resonators connected in a ladder network configuration. Pass band characteristics are determined by the relative resonant and anti-resonant frequencies of the resonators. Both narrow and wide pass band configurations are manufactured by adjusting the resonator frequency characteristics.

The IC (Integrated Circuit) has found wide use in the field of commercial equipment, such as automotive radios, stereo systems, 2-way communications, TV sets, etc. Thus, new miniature integrated filters, with high performance, are extremely desirable for use in IF circuits.

Furthermore, radio wave disturbance due to rapid progress of data transmitting rate and remarkable sophistication of communication network have become significant traffic conflicts. Accordingly, the demand for filters with high selectivity and wide pass band width has boosted.

The IC application of the active elements will continue its progress, and there will be a growing demand for highly selective, non-adjustable, miniature and wide pass band width IF circuit.

Advantage of Token Piezoelectric Filters

Token Electronics had been able to develop specialized piezo materials which when combined with an advance design have resulted in a complete line of practical, inexpensive piezo devices for entertainment and communications applications.

Token reliably deliver high-quality components according to the each customer special needs with respect to performance, costs, and technology modifications.

For marketing discontinuations or sourcing activities concerning Piezoelectric Filter products, you are encouraged to contact our Sales Department so the request can be properly directed within Token.



Communication Ceramic Filters

(LT 455/450 U/W)

▶ Product Introduction

Introduction (LT 455/450 U/W)

Features :

- LT455 EU Dimensions: (7.0 × 8.0 × 8.0 mm).
- LT455 EW Dimensions: (7.0 × 11.0 × 8.0 mm).
- Center frequency: 450kHz, 455kHz.
- Pass Band Ripple (dB) max: 2 db.
- Insertion Loss (dB) max: 4 db, 6 db.
- Input / Output Impedance: 1000Ω ~ 2000Ω.

Token Ceramic Filters Address the G.D.T. Characteristics for Communication (Murata CF, SF Compatible). Token ceramic filters for communication LT 455/450 U/W series are 4-element and 6-element devices connected in ladder form. These highly selective filters are designed to address the G.D.T. characteristics required in digital communications.

The excellent G.D.T. characteristics allow these filters to be utilized in areas such as the mobile cellular markets as well as a variety of stereo applications. (Also available in 450 kHz version.)

Custom parts are available on request. Token will also produce devices outside these specifications to meet specific customer requirements, please contact our sales or link to Token official website "[Ceramic Filters](#)" for more information.



► Dimensions

Dimensions (Unit: mm) (LT 455/450 U/W)

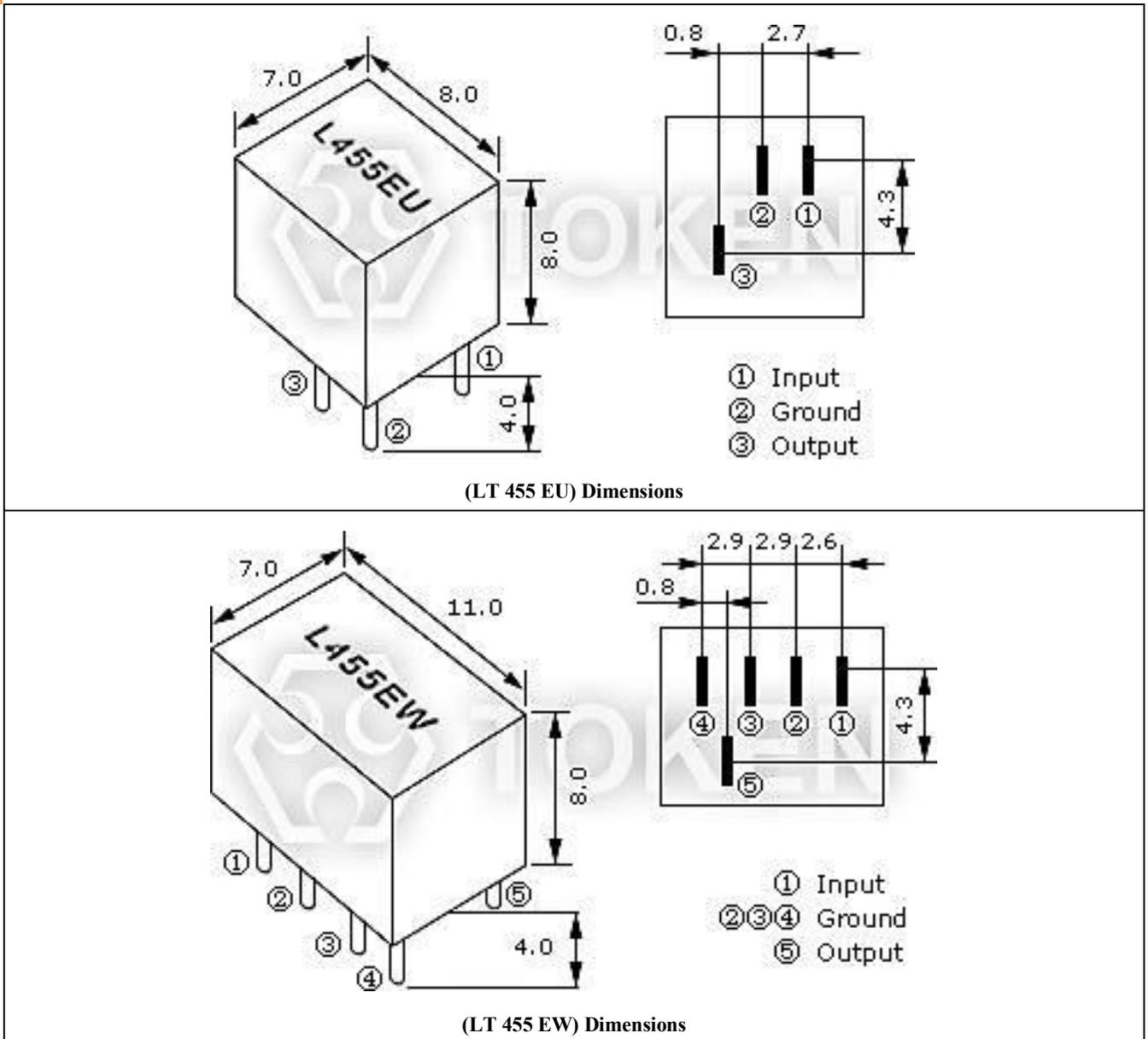

► Technical Characteristics

Technical Characteristics (LT 455/450 U/W)

Part Number		Center Frequency (kHz)	Insertion Loss (dB) max	Pass Band Ripple (dB) max	6dB Band Width (kHz) min	40dB Band Width (kHz) max (LT455 U)	50dB Band Width (kHz) max (LT455 W)	Spurious Attenuation fo±100kHz (dB) min		Input / Output Impedance (Ω)
								(LT455 U)	(LT455 W)	
LT455AU	LT455AW	455±2.0	4	2	±17.5	±40	±35	28	40	1000
LT455BU	LT455BW	455±2.0	4	2	±15	±30	±30	28	40	1500
LT455CU	LT455CW	455±2.0	4	2	±12.5	±24	±24	28	40	1500
LT455DU	LT455DW	455±1.5	4	2	±10	±20	±20	28	40	1500
LT455EU	LT455EW	455±1.5	6	2	±7.5	±15	±15	28	40	1500
LT455FU	LT455FW	455±1.5	6	2	±6	±12.5	±12.5	28	40	2000
LT455GU	LT455GW	455±1.5	6	2	±4.5	±10	±10	28	40	2000
LT455HU	LT455HW	455±1.0	6	2	±3	±9	±9	28	40	2000
LT455IU	LT455IW	455±1.0	6	2	±2	±7.5	±7.5	28	40	2000
LT455HTU	LT455HTW	455±1.0	6	2	±3	±9	±9	35	60	2000

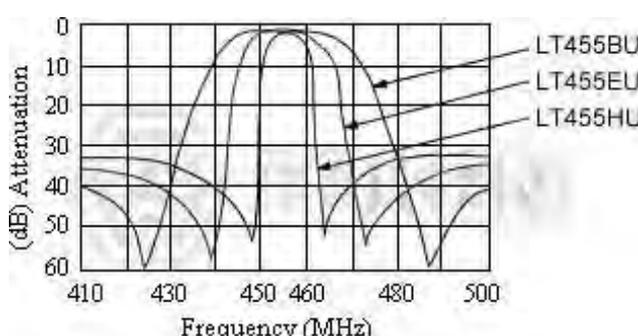

(LT 455 U) Characteristics

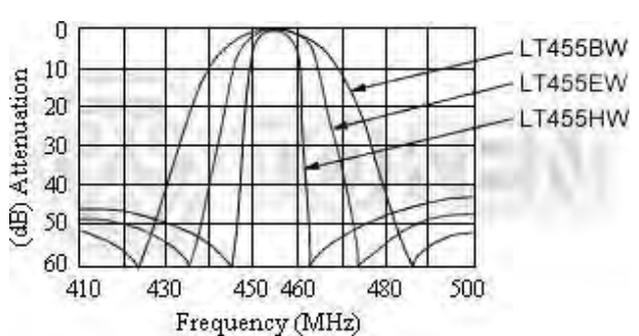

(LT 455 W) Characteristics

- Center frequency 450kHz is also available.



▶ Test Circuit

Test Circuit (LT 455/450 U/W)

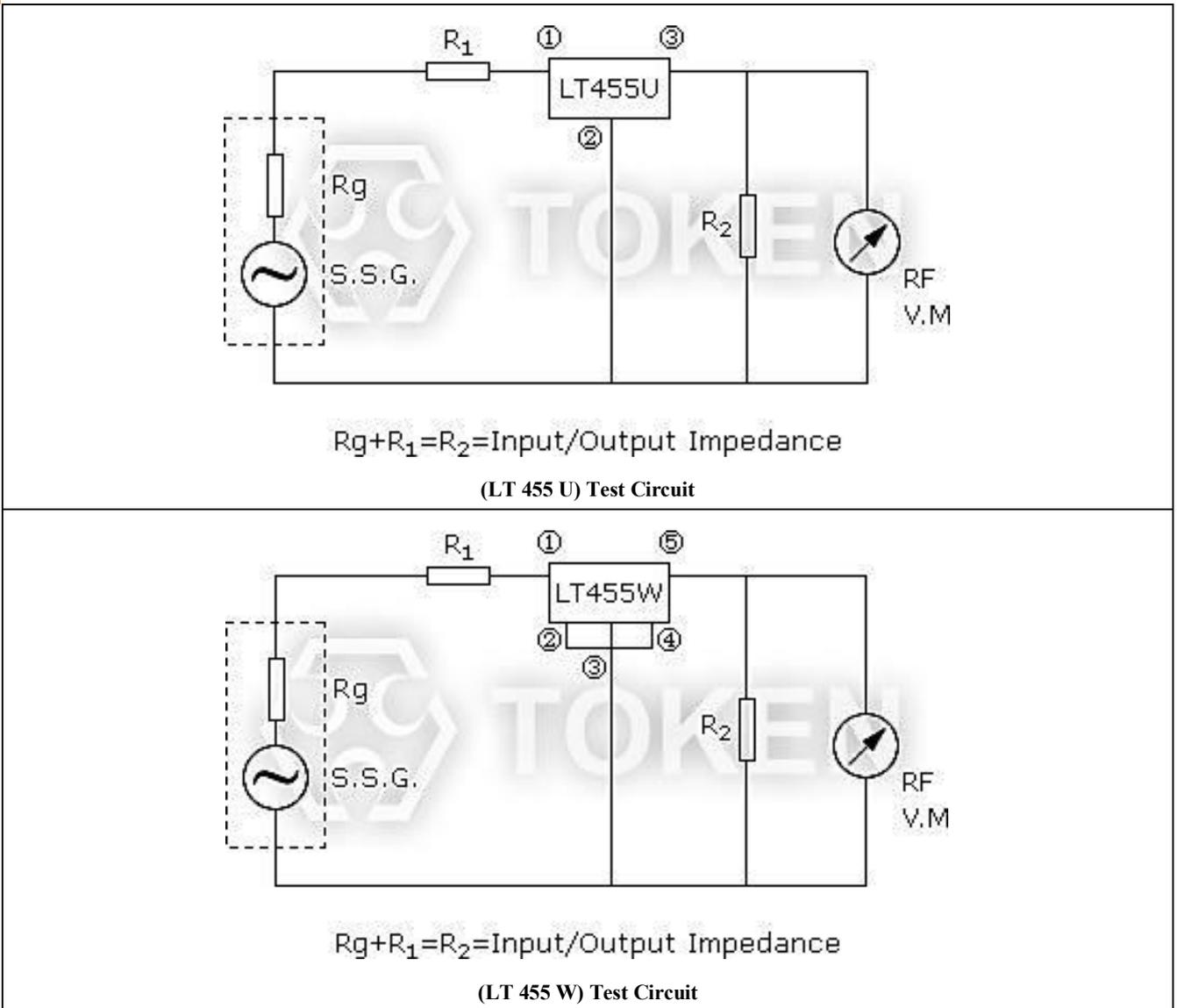

▶ Order Codes

Order Codes (LT 455/450 U/W)

LT455BU	P
Part Number	Package

▶ General Information

Introduction of Filters

For more than two decades, piezo technology has been instrumental in the proliferation of solid state electronics. A view of the future reveals that even greater expectations will be placed on piezoelectric material in the area of new applications and for more stringent performance criteria in modern products.

Token sophisticated ceramics technology has greatly increased selectivity and wide-band characteristics, and has stabilized the characteristics of ceramic filters. The series covers a wide range of attenuation and bandwidths to allow selection of the most optimum filter characteristics for each application.

Token filters are band pass filters consisting of one or more ceramic resonators connected in a ladder network configuration. Pass band characteristics are determined by the relative resonant and anti-resonant frequencies of the resonators. Both narrow and wide pass band configurations are manufactured by adjusting the resonator frequency characteristics.

The IC (Integrated Circuit) has found wide use in the field of commercial equipment, such as automotive radios, stereo systems, 2-way communications, TV sets, etc. Thus, new miniature integrated filters, with high performance, are extremely desirable for use in IF circuits.

Furthermore, radio wave disturbance due to rapid progress of data transmitting rate and remarkable sophistication of communication network have become significant traffic conflicts. Accordingly, the demand for filters with high selectivity and wide pass band width has boosted.

The IC application of the active elements will continue its progress, and there will be a growing demand for highly selective, non-adjustable, miniature and wide pass band width IF circuit.

Advantage of Token Piezoelectric Filters

Token Electronics had been able to develop specialized piezo materials which when combined with an advance design have resulted in a complete line of practical, inexpensive piezo devices for entertainment and communications applications.

Token reliably deliver high-quality components according to the each customer special needs with respect to performance, costs, and technology modifications.

For marketing discontinuations or sourcing activities concerning Piezoelectric Filter products, you are encouraged to contact our Sales Department so the request can be properly directed within Token.



Ceramic Filters (LTB)

▶ Product Introduction

Introduction (LTB)

(LTB) Ceramic Filter is perfect for Shrinking Mobile Communication Products. Token Ceramic Filter series conform to the RoHS directive and Lead-free.

Ceramic filters for communication (LTB) series can be customized designs and tighter tolerances available on request.

Application of ceramic filters specific designs also available including different piezo band-pass devices and Q specifications adjusted to frequency requirements.

Token ceramic filters for communication (LTB) series comprises small, high performance.

Their innovative construction is perfect for shrinking mobile communication products such as pocket pagers and cellular phones.

Operating temperature range: -20°C to $+80^{\circ}\text{C}$; Storage temperature range: -40°C to $+85^{\circ}\text{C}$.

Contact us with your specific needs. For more information, please link to Token official website "[Ceramic Filters](#)".



► Dimensions

Dimensions (Unit: mm) (LTB)

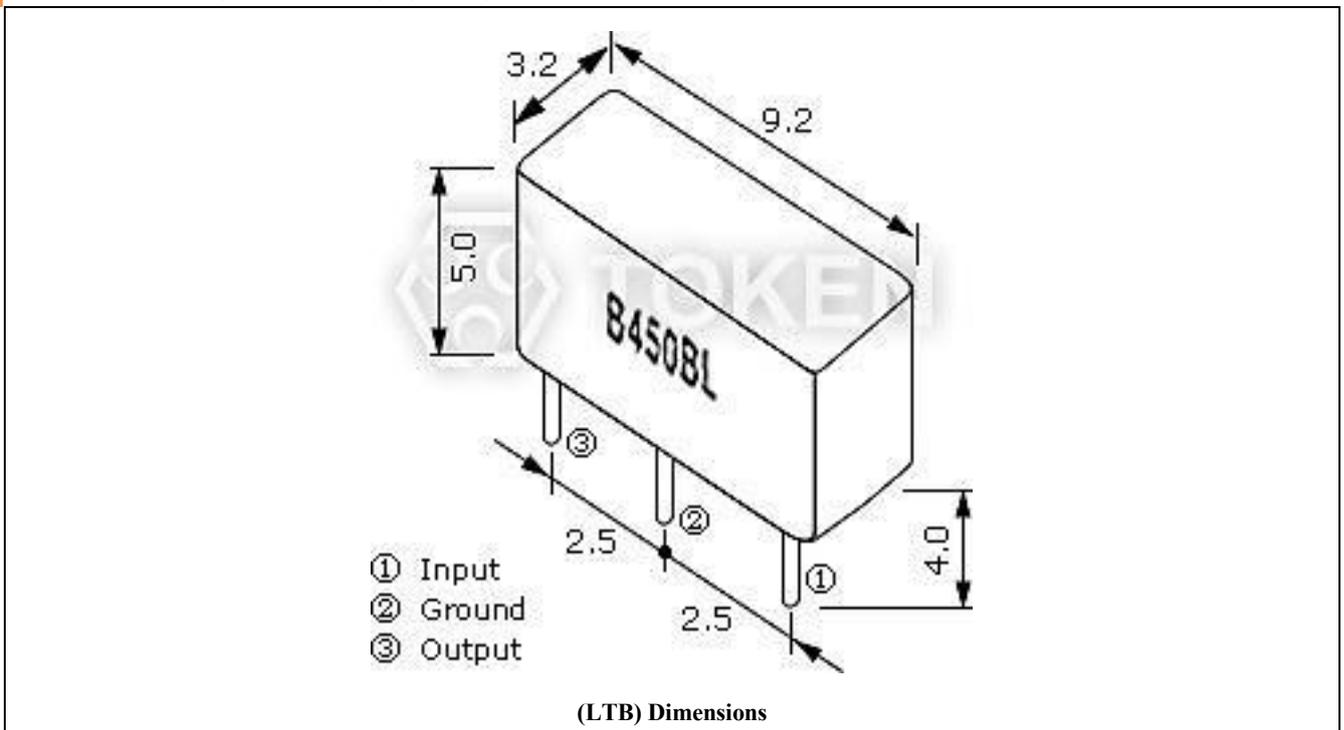

► Technical Characteristics

Technical Characteristics (LTB)

Part Number	Center Frequency (fo) (kHz)	6dB Band Width (kHz) min	Selectivity ± 9 kHz off (dB) min	Pass Band Ripple (dB) max	Insertion Loss (dB) max	Input / Output Impedance (Ω)
LTB450AL2	450 \pm 2	4	18	1.0	6.8	1.0/1.5
LTB455AL2	455 \pm 2					
LTB465AL2	465 \pm 2					
LTB450BL2	450 \pm 2	6	16	1.0	5.8	1.5/2.0
LTB455BL2	455 \pm 2					
LTB465BL2	465 \pm 2					

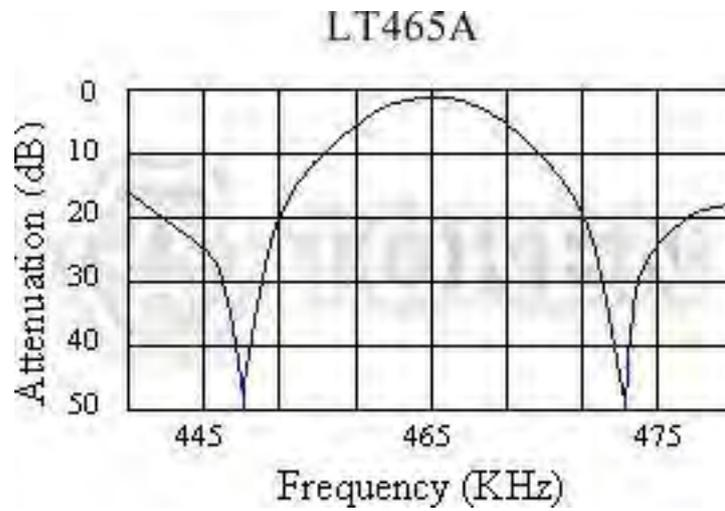

(LTB) Technical Characteristics

▶ Test Circuit

Test Circuit (LTB)

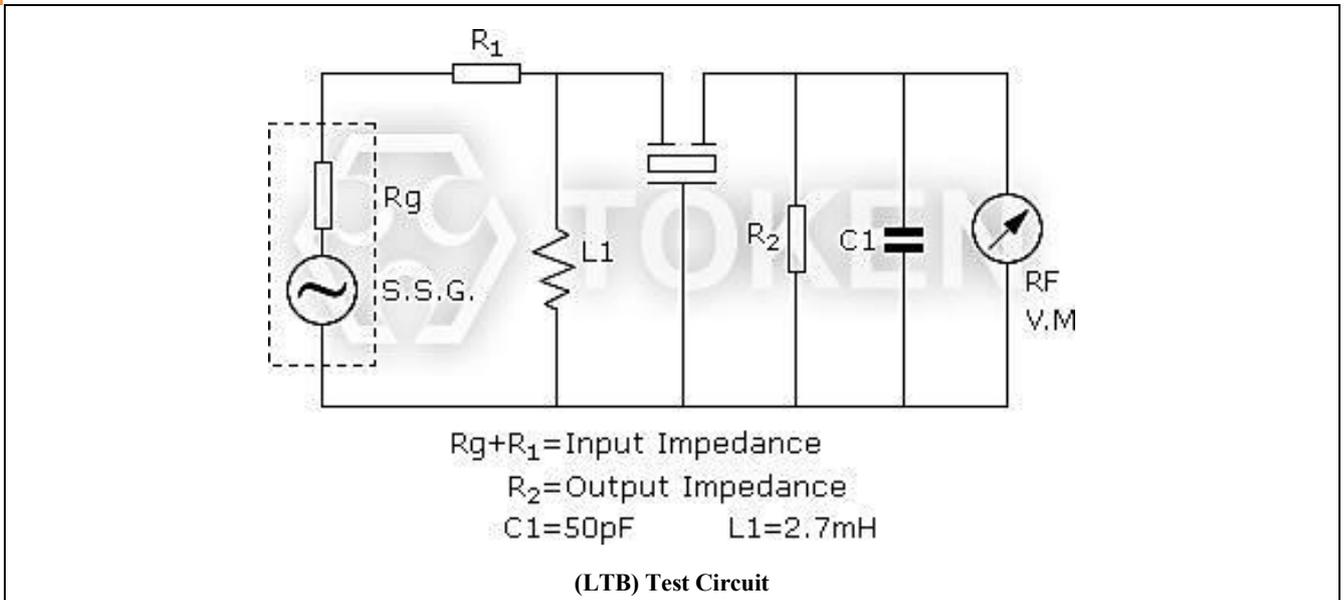

▶ Order Codes

Order Codes (LTB)

LTB450AL2	P
Part Number	Package

▶ General Information

Introduction of Filters

For more than two decades, piezo technology has been instrumental in the proliferation of solid state electronics. A view of the future reveals that even greater expectations will be placed on piezoelectric material in the area of new applications and for more stringent performance criteria in modern products.

Token sophisticated ceramics technology has greatly increased selectivity and wide-band characteristics, and has stabilized the characteristics of ceramic filters. The series covers a wide range of attenuation and bandwidths to allow selection of the most optimum filter characteristics for each application.

Token filters are band pass filters consisting of one or more ceramic resonators connected in a ladder network configuration. Pass band characteristics are determined by the relative resonant and anti-resonant frequencies of the resonators. Both narrow and wide pass band configurations are manufactured by adjusting the resonator frequency characteristics.

The IC (Integrated Circuit) has found wide use in the field of commercial equipment, such as automotive radios, stereo systems, 2-way communications, TV sets, etc. Thus, new miniature integrated filters, with high performance, are extremely desirable for use in IF circuits.

Furthermore, radio wave disturbance due to rapid progress of data transmitting rate and remarkable sophistication of communication network have become significant traffic conflicts. Accordingly, the demand for filters with high selectivity and wide pass band width has boosted.

The IC application of the active elements will continue its progress, and there will be a growing demand for highly selective, non-adjustable, miniature and wide pass band width IF circuit.

Advantage of Token Piezoelectric Filters

Token Electronics had been able to develop specialized piezo materials which when combined with an advance design have resulted in a complete line of practical, inexpensive piezo devices for entertainment and communications applications.

Token reliably deliver high-quality components according to the each customer special needs with respect to performance, costs, and technology modifications.

For marketing discontinuations or sourcing activities concerning Piezoelectric Filter products, you are encouraged to contact our Sales Department so the request can be properly directed within Token.



Communication Ceramic Chip Filters (LTC455/450 U/W)

▶ Product Introduction

Introduction (LTC455/450 U/W)

Features :

- They are slim, at only 4.0mm max. thickness, and have a small mounting area enabling flexible PCB design.
- Operating temperature range: -20°C to +80°C.
- Can be reflow soldered and withstand washing.
- The bandwidth ranges from D to G.
- Mountable by automatic placers.

Token (LTC455/450 U/W) surface mount communication ceramic chip filters are compatible with Murata filter CFUCG. The (LTC455/450 U/W) series for communication filter comprises small, high performance, thin (4.0mm) consisting of 4 ceramic elements. Their innovative construction is perfect for shrinking mobile communication products such as pocket pagers and cellular phones.

The surface mount LTC455/450 U/W series for AM use is one of the most recommendable intermediate filters, having such distinctive features as high selectivity, high stability and adjustment-free operation. Additionally its easy matching with IC helps create an easy circuit design.

With dimensions (7.5 × 6.0 mm) and 4.0 mm low profile, the LTC455/450 U/W filters have a small mounting area enabling flexible PCB design and are suitable for automatic placers. Standard Center Frequency is 455 kHz with tolerance ±1.5 and 450 kHz is also available. Pass Band Ripple (dB) max is 2db, Input / Output Impedance is 1000Ω and 1500Ω.

Custom parts are available on request. Token will also produce devices outside these specifications to meet specific customer requirements, please contact our sales or link to Token official website "[Ceramic Filters](#)" for more information.



► Dimensions

Dimensions (Unit: mm) (LTC 455/450 U/W)

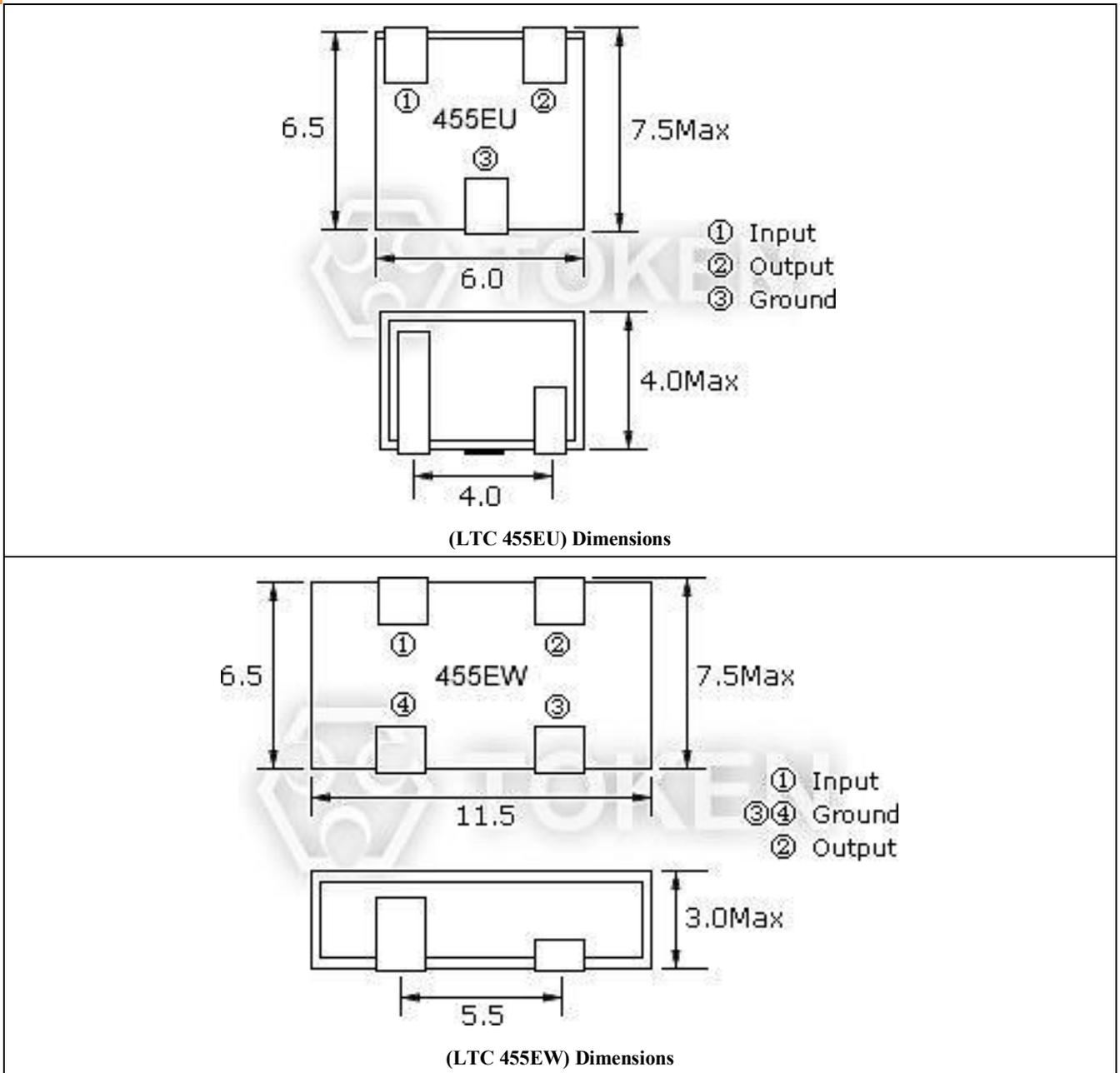

► Technical Characteristics

Technical Characteristics (LTC 455/450 U/W)

Part Number		Center Frequency (fo)(kHz)	Insertion Loss (dB)max		Pass Band Ripple (dB) max	6dB Band Width (kHz) min	40dB Band Width (kHz) max LTC455U	50dB Band Width (kHz) max LTC455W	Spurious Attenuation fo±100kHz (dB) min		Input / Output Impedance (Ω)
			LTC 455U	LTC 455W					LTC 455U	LTC 455W	
LTC455BU	LTC455BW	455±1.5	4	4	2	±15.0	±30	±30	27	50	1000
LTC455CU	LTC455CW	455±1.5	4	4	2	±12.5	±25	±25	27	50	1000
LTC455DU	LTC455DW	455±1.5	4	4	2	±10.0	±20	±20	27	50	1500
LTC455EU	LTC455EW	455±1.5	6	4	2	±7.5	±15	±15	27	50	1500
LTC455FU	LTC455FW	455±1.5	6	6	2	±6.0	±12	±12	27	47	1500
LTC455GU	LTC455GW	455±1.5	6	6	2	±4.5	±10	±10	25	47	1500
LTC455HU	LTC455HW	455±1.5	6	6	2	±3.0	±9.0	±9.0	25	47	1500
LTC455IU	LTC455IW	455±1.5	6	6	2	±2.0	±7.5	±7.5	25	47	1500

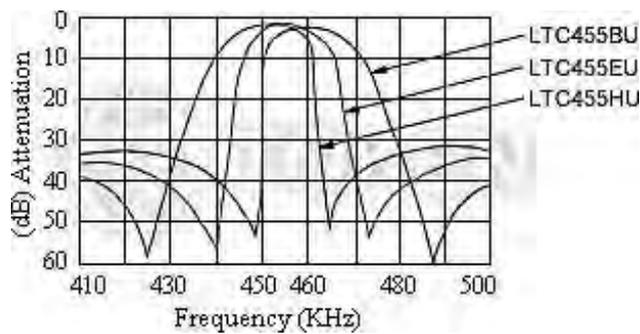

(LTC 455 U) Characteristics

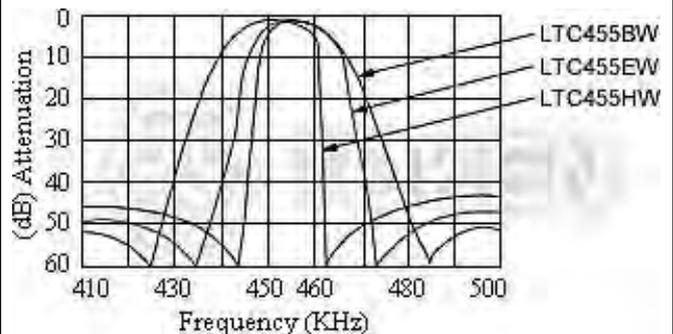

(LTC 455 W) Characteristics

- Center frequency 450kHz is also available.

▶ Test Circuit

Test Circuit (LTC 455/450 U/W)

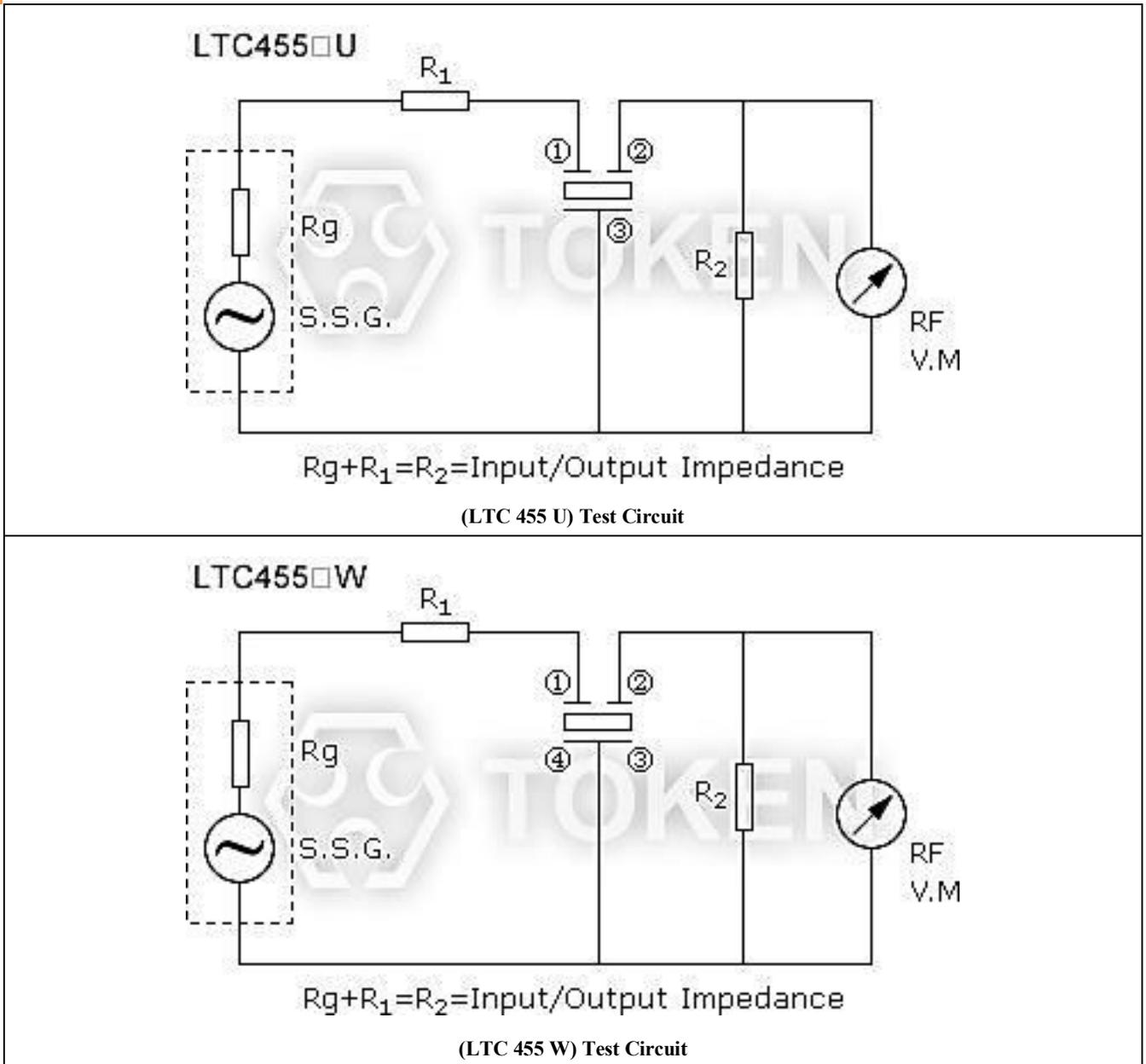

▶ Order Codes

Order Codes (LTC 455/450 U/W)

LTC455BU	P
Part Number	Package

► General Information

Introduction of Filters

For more than two decades, piezo technology has been instrumental in the proliferation of solid state electronics. A view of the future reveals that even greater expectations will be placed on piezoelectric material in the area of new applications and for more stringent performance criteria in modern products.

Token sophisticated ceramics technology has greatly increased selectivity and wide-band characteristics, and has stabilized the characteristics of ceramic filters. The series covers a wide range of attenuation and bandwidths to allow selection of the most optimum filter characteristics for each application.

Token filters are band pass filters consisting of one or more ceramic resonators connected in a ladder network configuration. Pass band characteristics are determined by the relative resonant and anti-resonant frequencies of the resonators. Both narrow and wide pass band configurations are manufactured by adjusting the resonator frequency characteristics.

The IC (Integrated Circuit) has found wide use in the field of commercial equipment, such as automotive radios, stereo systems, 2-way communications, TV sets, etc. Thus, new miniature integrated filters, with high performance, are extremely desirable for use in IF circuits.

Furthermore, radio wave disturbance due to rapid progress of data transmitting rate and remarkable sophistication of communication network have become significant traffic conflicts. Accordingly, the demand for filters with high selectivity and wide pass band width has boosted.

The IC application of the active elements will continue its progress, and there will be a growing demand for highly selective, non-adjustable, miniature and wide pass band width IF circuit.

Advantage of Token Piezoelectric Filters

Token Electronics had been able to develop specialized piezo materials which when combined with an advance design have resulted in a complete line of practical, inexpensive piezo devices for entertainment and communications applications.

Token reliably deliver high-quality components according to the each customer special needs with respect to performance, costs, and technology modifications.

For marketing discontinuations or sourcing activities concerning Piezoelectric Filter products, you are encouraged to contact our Sales Department so the request can be properly directed within Token.



SMD Ceramic Filters (LTCA/CV10.7M)

▶ Product Introduction

**SMD Ceramic Filters with Low Profile 1.5 ± 0.2 mm,
Murata SFECV10M7 Compatible.**

Applications :

- Small, thin radios, automotive radios.
- Headphone stereos.

Token surface mount ceramic (LTCA/CV10.7M) filter for AM/FM has been made smaller, thinner and in a chip configuration for surface mounting to be of help to the total chip circuit. This is one more example of Token's leadership in converting conventional electronic components to chip technology.

The LTCA/CV10.7M series for FM-receivers are monolithic type ceramic filters which utilize the thickness expander mode of the piezoelectric ceramic. Piezoelectric element is connected in the sandwich shape by heat resistant substrate, thus it has excellent mechanical strength, and it is suitable for automatic mounting.

The dimensions of LTCA/CV10.7M ceramic chip filter is small as $7.0\pm 0.3 \times 3.0\pm 0.3$ mm with low profile 1.5 ± 0.2 mm. Insertion Loss max(dB) is from 3.0 db ~ 10 db, Spurious Attenuation (9~12 MHz) min(dB) 30 db ~ 35 db with Input/Output Impedance: 330Ω . Various bandwidths are available. Select a suitable type in accordance with the desired selectivity.

The LTCA/CV10.7M series conform to the RoHS directive. Token will also produce devices outside these specifications to meet specific customer requirements, please contact our sales or link to Token official website "[Ceramic Filters](http://www.token.com.tw)" for more information.



► Dimensions

Dimensions (Unit: mm) (LTCA/CV10.7M)

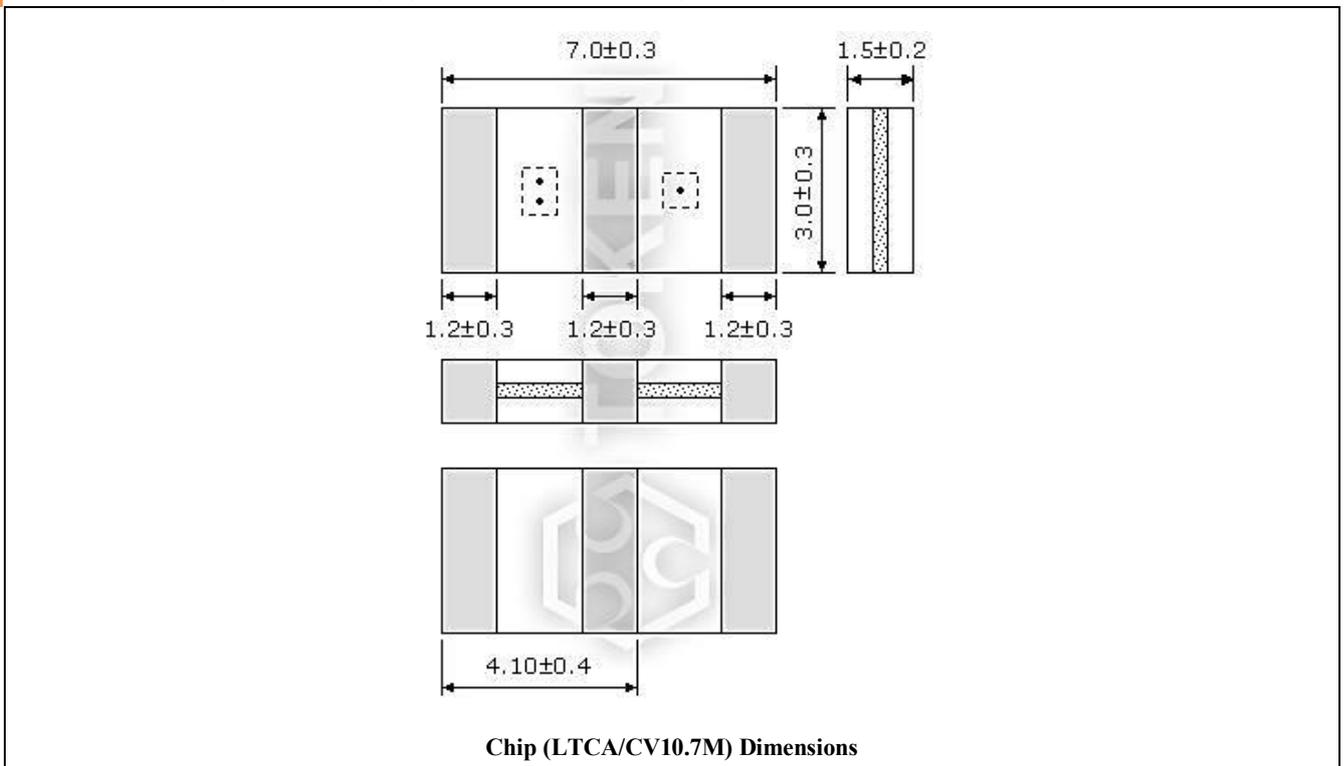

Chip (LTCA/CV10.7M) Dimensions

▶ Technical Characteristics

Technical Characteristics (LTCA/CV10.7M)

Part Number	3dB Band Width (kHz)	20dB Band Width (kHz) max	Insertion Loss (dB)max	Spurious Attenuation (9-12MHz)(dB)min
LTCA10.7MJ	150±40	430	10.0	30
LTCV10.7MJ	150±40	380	5.5±2.0	35
LTCA10.7MA5	280±50	650	6.0	30
LTCV10.7MA5	280±50	590	3.0±2.0	35
LTCA10.7MS2	230±50	570	6.0	30
LTCV10.7MS2	230±50	510	3.5±2.0	35
LTCA10.7MS3	180±40	520	6.0	30
LTCV10.7MS3	180±40	470	4.0±2.0	35

● Input/Output Impedance: 330Ω

▶ Order Codes

Order Codes (LTCA/CV10.7M)

LTCV10.7MA5	TR
Part Number	Package (TR:Taping Reel)

▶ General Information

Introduction of Filters

For more than two decades, piezo technology has been instrumental in the proliferation of solid state electronics. A view of the future reveals that even greater expectations will be placed on piezoelectric material in the area of new applications and for more stringent performance criteria in modern products.

Token sophisticated ceramics technology has greatly increased selectivity and wide-band characteristics, and has stabilized the characteristics of ceramic filters. The series covers a wide range of attenuation and bandwidths to allow selection of the most optimum filter characteristics for each application.

Token filters are band pass filters consisting of one or more ceramic resonators connected in a ladder network configuration. Pass band characteristics are determined by the relative resonant and anti-resonant frequencies of the resonators. Both narrow and wide pass band configurations are manufactured by adjusting the resonator frequency characteristics.

The IC (Integrated Circuit) has found wide use in the field of commercial equipment, such as automotive radios, stereo systems, 2-way communications, TV sets, etc. Thus, new miniature integrated filters, with high performance, are extremely desirable for use in IF circuits.

Furthermore, radio wave disturbance due to rapid progress of data transmitting rate and remarkable sophistication of communication network have become significant traffic conflicts. Accordingly, the demand for filters with high selectivity and wide pass band width has boosted.

The IC application of the active elements will continue its progress, and there will be a growing demand for highly selective, non-adjustable, miniature and wide pass band width IF circuit.

Advantage of Token Piezoelectric Filters

Token Electronics had been able to develop specialized piezo materials which when combined with an advance design have resulted in a complete line of practical, inexpensive piezo devices for entertainment and communications applications.

Token reliably deliver high-quality components according to the each customer special needs with respect to performance, costs, and technology modifications.

For marketing discontinuations or sourcing activities concerning Piezoelectric Filter products, you are encouraged to contact our Sales Department so the request can be properly directed within Token.



Ceramic Chip Filters (LTCS10.7M)

► Product Introduction

**LTCS10.7M Low Profile Ceramic Chip Filter is Murata
SF ECS10M7 Compatible.**

Features :

- Various bandwidths are available. Select a suitable type in accordance with the desired selectivity.
- Slim at only 1.4 mm max. thickness, and have a small mounting area enabling flexible PCB design.
- Operating temperature range: -20 to +80 (°C).
- Storage temperature range: -40 to +85 (°C).
- Mountable by automatic placers.

Applications :

- Small, thin radios.
- Headphone stereos.

Token LTCS10.7M Chip Ceramic Filter for FM-receiver utilizes the latest piezoelectric ceramic technology enabling the most cost-effective designs. The LTCS10.7M constructs with piezoelectric element which is connected in the sandwich shape by ceramics substrate. With a small mounting area ($3.45 \pm 0.2 \times 3.1 \pm 0.2$ mm) and super thin profile (1.4 mm max.) enables flexible PCB design. Products conform to the RoHS directive.

Various bandwidths are available including standard and custom bandwidth on request with 30 dB Minimum Spurious Attenuation at (9-12MHz). Maximum Insertion Loss (dB) 3.5 ± 2.0 dB ~ 4.5 ± 2.0 dB and Input/output Impedance 330Ω provide customers select a suitable type in accordance with the desired selectivity.

Custom parts are available on request. Token will also produce devices outside these specifications to meet specific customer requirements, please contact our sales or link to Token official website "[Ceramic Filters](#)" for more information.



► Dimensions

Dimensions (Unit: mm) (LTCS10.7M)

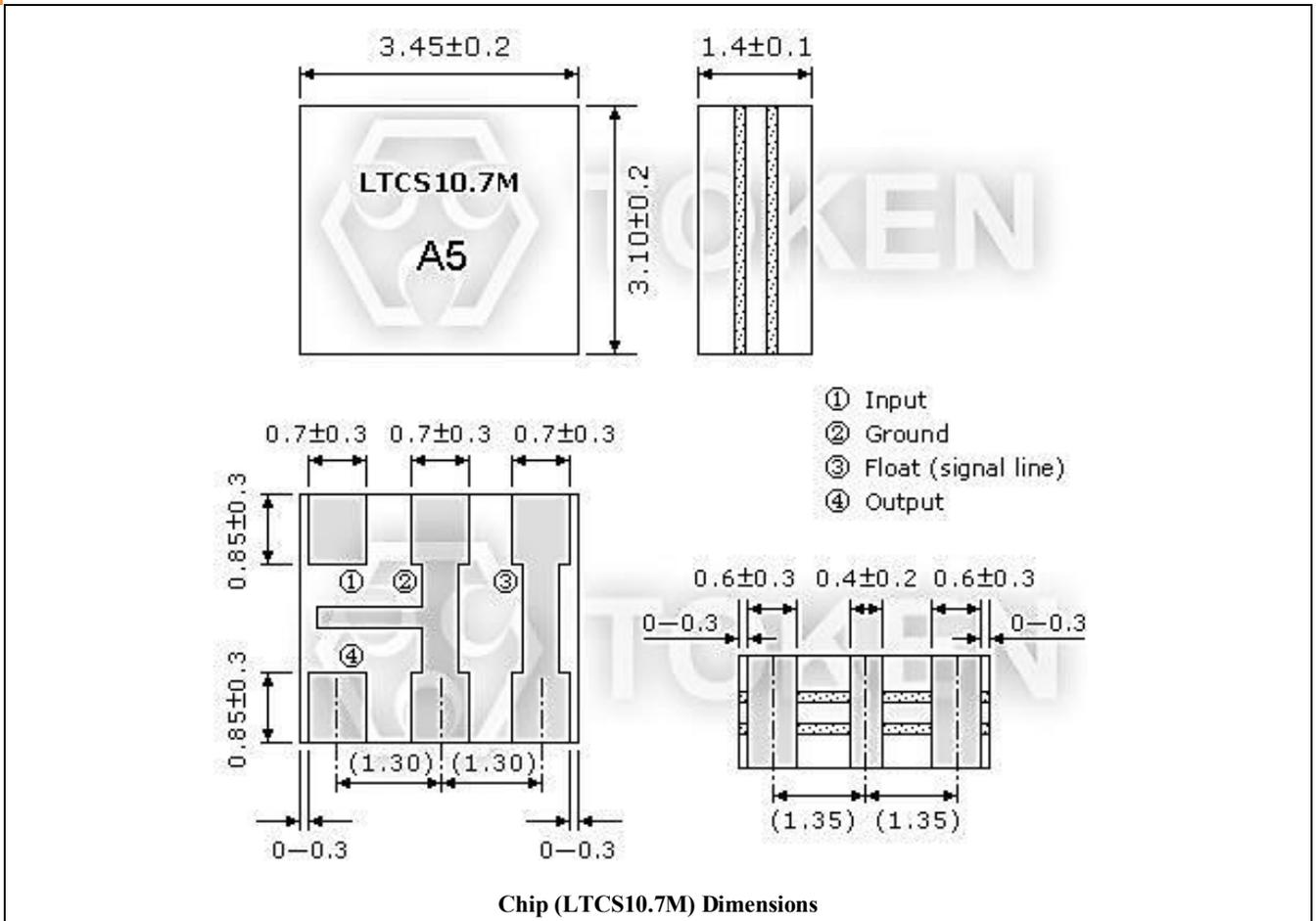

► Technical Characteristics

Technical Characteristics (LTCS10.7M)

Part Number	3dB Band Width (kHz)	20dB Band Width (kHz)max	Insertion Loss (dB)max	Spurious Attenuation (9-12MHz)(dB)min
LTCS10.7MS2	230±50	510	3.5±2.0	30
LTCS10.7MS3	180±40	470	4.5±2.0	30
LTCS10.7MA5	280±50	590	3.0±2.0	30
LTCS10.7MA20	330±50	700	3.0±2.0	30

● Input/Output Impedance: 330Ω

▶ Test Circuit

Test Circuit (LTCS10.7M)

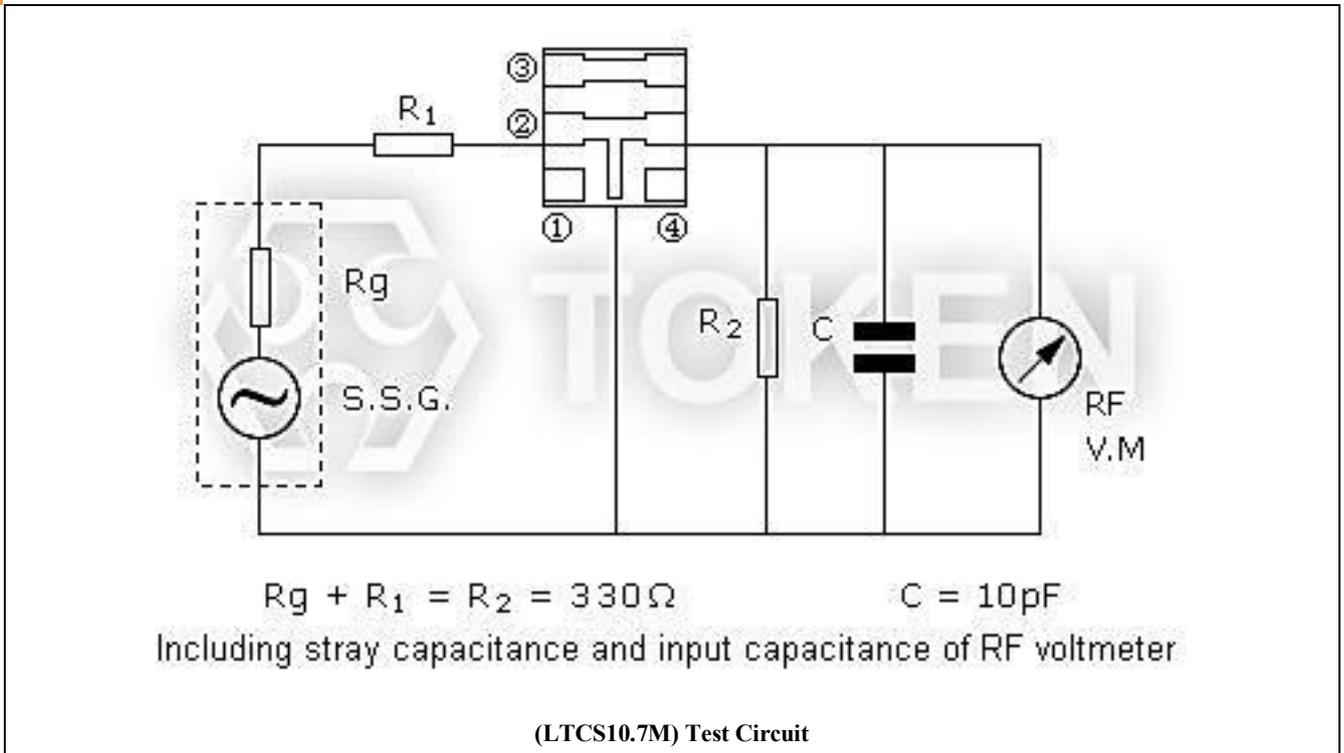

▶ Order Codes

Order Codes (LTCS10.7M)

LTCS10.7MS2	TR
Part Number	Package (TR: Taping Reel)

▶ General Information

Introduction of Filters

For more than two decades, piezo technology has been instrumental in the proliferation of solid state electronics. A view of the future reveals that even greater expectations will be placed on piezoelectric material in the area of new applications and for more stringent performance criteria in modern products.

Token sophisticated ceramics technology has greatly increased selectivity and wide-band characteristics, and has stabilized the characteristics of ceramic filters. The series covers a wide range of attenuation and bandwidths to allow selection of the most optimum filter characteristics for each application.

Token filters are band pass filters consisting of one or more ceramic resonators connected in a ladder network configuration. Pass band characteristics are determined by the relative resonant and anti-resonant frequencies of the resonators. Both narrow and wide pass band configurations are manufactured by adjusting the resonator frequency characteristics.

The IC (Integrated Circuit) has found wide use in the field of commercial equipment, such as automotive radios, stereo systems, 2-way communications, TV sets, etc. Thus, new miniature integrated filters, with high performance, are extremely desirable for use in IF circuits.

Furthermore, radio wave disturbance due to rapid progress of data transmitting rate and remarkable sophistication of communication network have become significant traffic conflicts. Accordingly, the demand for filters with high selectivity and wide pass band width has boosted.

The IC application of the active elements will continue its progress, and there will be a growing demand for highly selective, non-adjustable, miniature and wide pass band width IF circuit.

Advantage of Token Piezoelectric Filters

Token Electronics had been able to develop specialized piezo materials which when combined with an advance design have resulted in a complete line of practical, inexpensive piezo devices for entertainment and communications applications.

Token reliably deliver high-quality components according to the each customer special needs with respect to performance, costs, and technology modifications.

For marketing discontinuations or sourcing activities concerning Piezoelectric Filter products, you are encouraged to contact our Sales Department so the request can be properly directed within Token.



Communication Ceramic Filters

(LTM 455/450 U/W)

▶ Product Introduction

Introduction (LTM 455/450 U/W)

Features :

- LTM 455 EU Dimensions: (6.5 × 6.5 × 6.2 mm).
- LTM 455 EW Dimensions: (6.5 × 9.5 × 6.2 mm).
- Center Frequency: 455kHz (450kHz is also available).
- Input / Output Impedance: 1000Ω ~ 2000Ω.
- Insertion Loss (dB) max: 4db, 6db.
- Pass Band Ripple (dB) max: 2db.

Token communication ceramic filter is Murata CFUM/WM 455/450 compatible. Token ceramic filters for communication LTM 455/450 U/W series are miniaturized versions of the Murata CFU/CFWS lines.

These compact, highly selective characteristics are recommended for use in applications ranging from two-way radio to auxiliary filters in high class transceivers.

These ultra-miniature versions consume approximately 40% less volume while still offering the same high performance filter characteristics.

Contact us with your specific needs. For more information, please link to Token official website "[Ceramic Filters](#)".



► Dimensions

Dimensions (Unit: mm) (LTM 455/450 U/W)

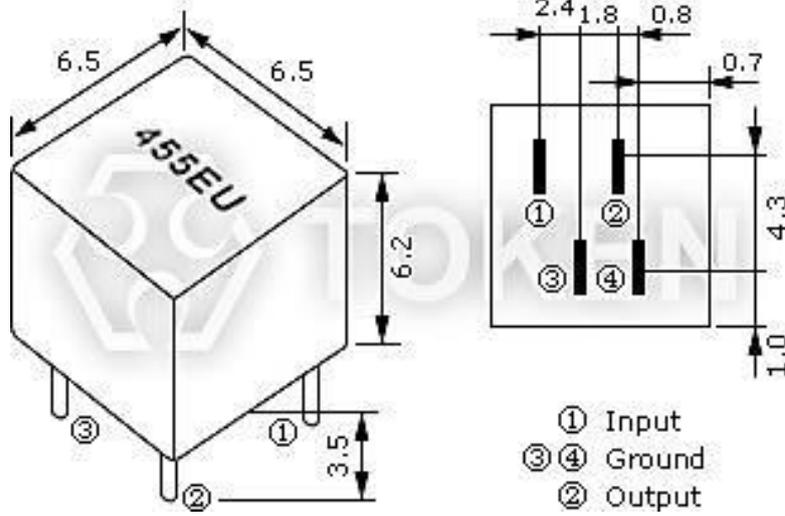

(LTM 455 EU) Dimensions

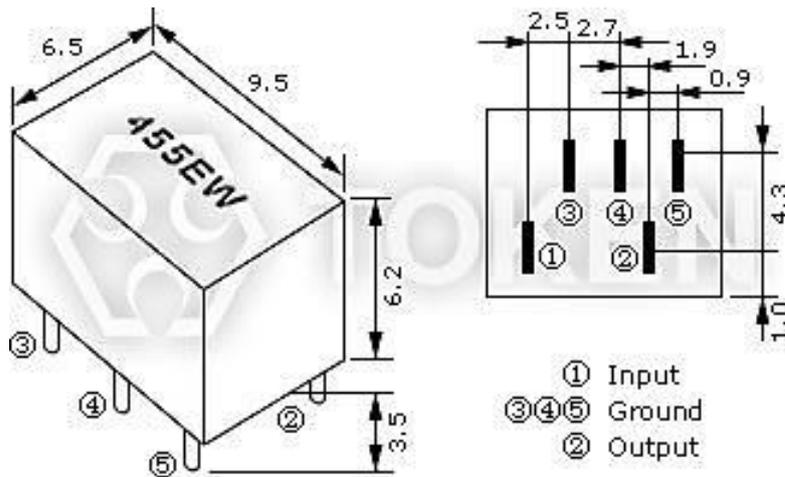

(LTM 455 EW) Dimensions

► Technical Characteristics

Technical Characteristics (LTM 455/450 U/W)

Part Number		Center Frequency (kHz)	Insertion Loss (dB) max	Pass Band Ripple (dB) max	6dB Band Width (kHz) min	40dB Band Width (kHz) max LTM455 U	50dB Band Width (kHz) max LTM455 W	Spurious Attenuation fo±100kHz (dB) min		Input / Output Impedance (Ω)
								LTM455 U	LTM455 W	
LTM455AU	LTM455AW	455±2.0	4	2	±17.5	±40	±35	28	40	1000
LTM455BU	LTM455BW	455±2.0	4	2	±15	±30	±30	28	40	1500
LTM455CU	LTM455CW	455±2.0	4	2	±12.5	±24	±24	28	40	1500
LTM455DU	LTM455DW	455±1.5	4	2	±10	±20	±20	28	40	1500
LTM455EU	LTM455EW	455±1.5	6	2	±7.5	±15	±15	28	40	1500
LTM455FU	LTM455FW	455±1.5	6	2	±6	±12.5	±12.5	28	40	2000
LTM455GU	LTM455GW	455±1.5	6	2	±4.5	±10	±10	28	40	2000
LTM455HU	LTM455HW	455±1.0	6	2	±3	±9	±9	28	40	2000
LTM455IU	LTM455IW	455±1.0	6	2	±2	±7.5	±7.5	28	40	2000
LTM455HTU	LTM455HTW	455±1.0	6	2	±3	±9	±9	35	60	2000

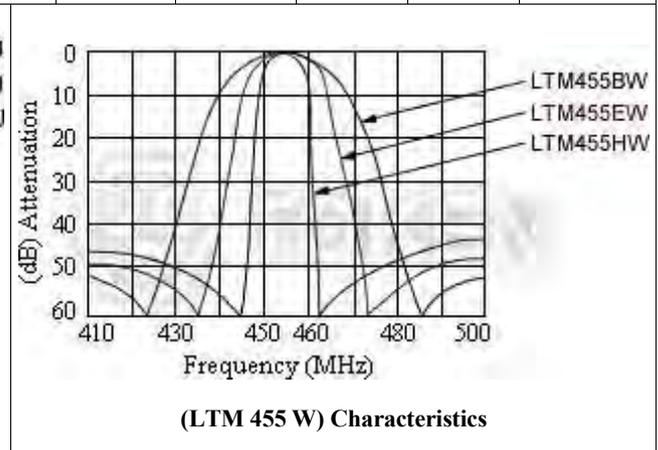
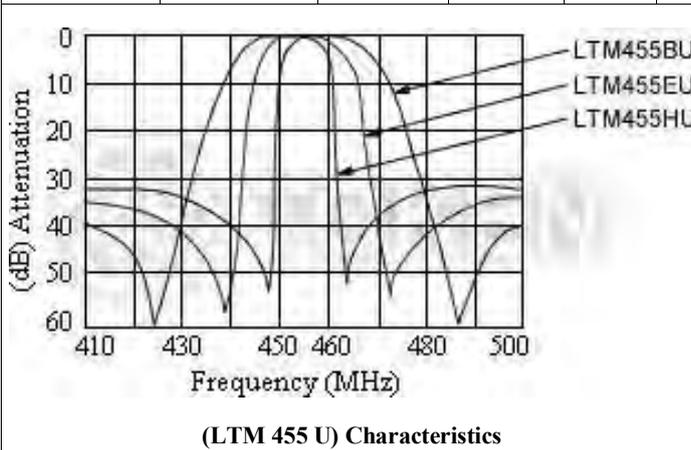

- Center frequency 450kHz is also available.

▶ Test Circuit

Test Circuit (LTM 455/450 U/W)

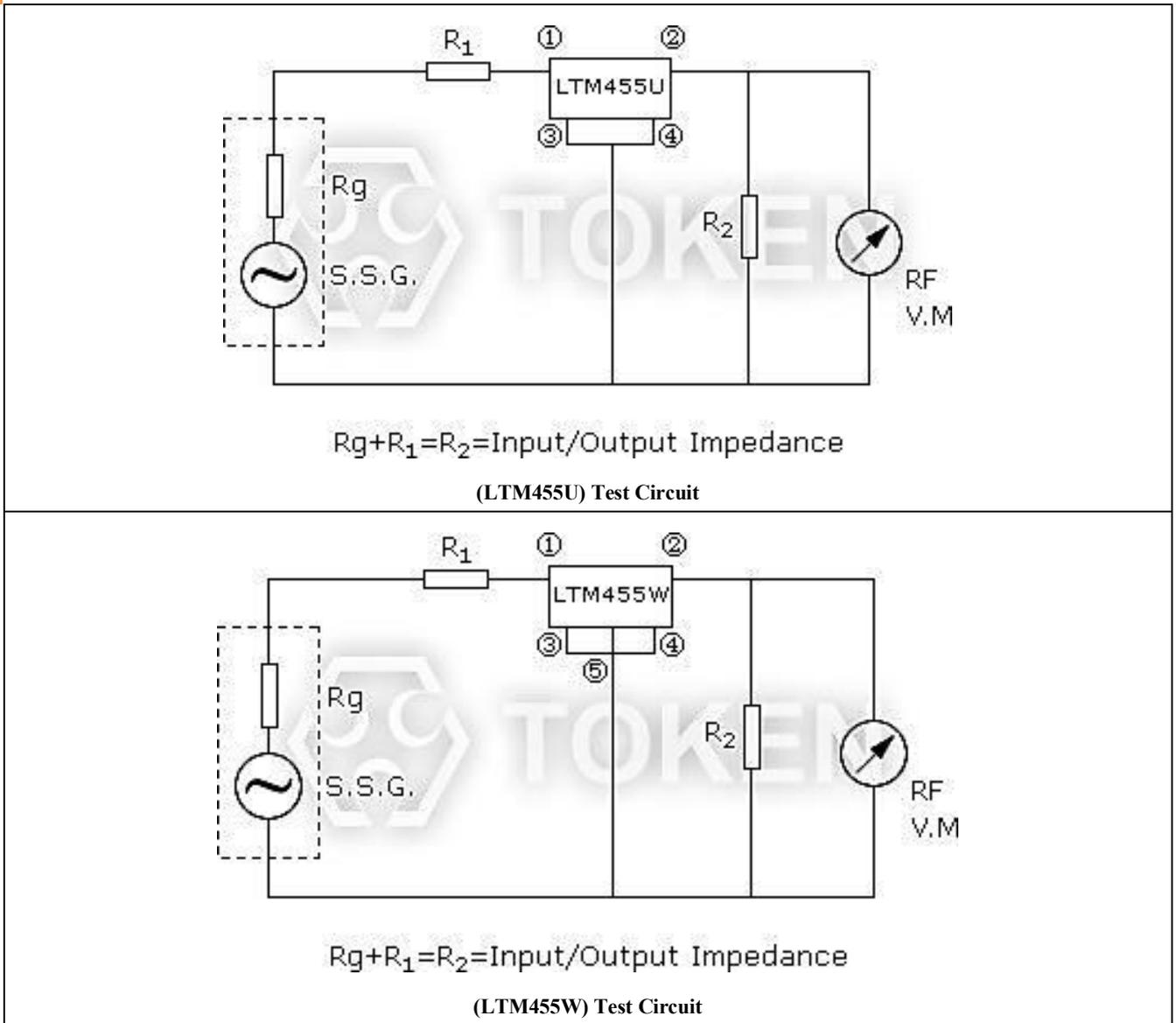

▶ Order Codes

Order Codes (LTM 455/450 U/W)

LTM455BU	P
Part Number	Package

▶ General Information

Introduction of Filters

For more than two decades, piezo technology has been instrumental in the proliferation of solid state electronics. A view of the future reveals that even greater expectations will be placed on piezoelectric material in the area of new applications and for more stringent performance criteria in modern products.

Token sophisticated ceramics technology has greatly increased selectivity and wide-band characteristics, and has stabilized the characteristics of ceramic filters. The series covers a wide range of attenuation and bandwidths to allow selection of the most optimum filter characteristics for each application.

Token filters are band pass filters consisting of one or more ceramic resonators connected in a ladder network configuration. Pass band characteristics are determined by the relative resonant and anti-resonant frequencies of the resonators. Both narrow and wide pass band configurations are manufactured by adjusting the resonator frequency characteristics.

The IC (Integrated Circuit) has found wide use in the field of commercial equipment, such as automotive radios, stereo systems, 2-way communications, TV sets, etc. Thus, new miniature integrated filters, with high performance, are extremely desirable for use in IF circuits.

Furthermore, radio wave disturbance due to rapid progress of data transmitting rate and remarkable sophistication of communication network have become significant traffic conflicts. Accordingly, the demand for filters with high selectivity and wide pass band width has boosted.

The IC application of the active elements will continue its progress, and there will be a growing demand for highly selective, non-adjustable, miniature and wide pass band width IF circuit.

Advantage of Token Piezoelectric Filters

Token Electronics had been able to develop specialized piezo materials which when combined with an advance design have resulted in a complete line of practical, inexpensive piezo devices for entertainment and communications applications.

Token reliably deliver high-quality components according to the each customer special needs with respect to performance, costs, and technology modifications.

For marketing discontinuations or sourcing activities concerning Piezoelectric Filter products, you are encouraged to contact our Sales Department so the request can be properly directed within Token.



Ceramic Filters (LT MB)

► Product Introduction

Ceramic Filters for TV/VCR Stage (Murata SFE MB Compatible) 4.5 MHz ~ 6.5 MHz.

Features :

- Excellent spurious suppression characteristics within video signal band.
- Available 4 pass bandwidth variation to meet various requests.
- Low profile (H = 10.0mm max.).

Token utilizes the latest piezo filter technology enabling the most cost-effective designs in manufacturing LT MB series. The ceramic filter is primarily designed for piezoelectric lines and conforms to the RoHS directive and Lead-free. Ceramic filters for TV/VCR stage LT MB series can be customized designs and tighter tolerances available on request.

Application of ceramic filters specific designs also available including different piezo band-pass devices and Q specifications adjusted to frequency requirements. Token ceramic filters can supply you high performance, high quality and stability.

Token ceramic filters LT MB series are a high selectivity filter for 2 channel multi-sounds TV. Features with frequency adjustment-free, high performance and durability, and high selectivity.

Contact us with your specific needs. For more information, please link to Token official website "[Ceramic Filters](#)".



► Dimensions

Dimensions (Unit: mm) (LT MB)

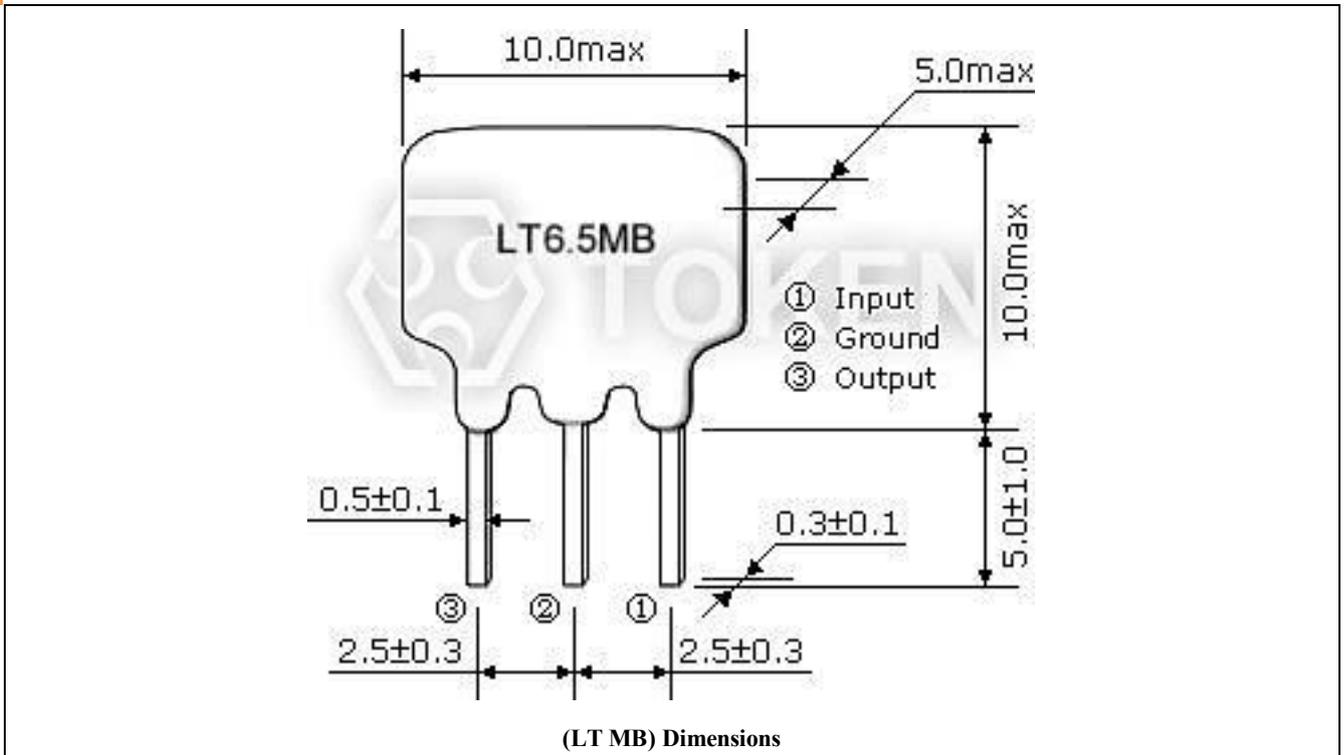

► Technical Characteristics

Technical Characteristics (LT MB)

Part Number	Nominal Center Frequency (fo) (MHz)	3dB Band Width (kHz) min	20dB Band Width (kHz) max	Insert Loss (dB) max	Spurious Attenuation (dB) min	Input/Output Impedance (Ω)
LT4.5MB	4.500	fo±60	530	6.0	20(4.5 ^{+0.8} _{-1.0} MHz)	1000
LT5.5MB	5.500	fo±75	550	6.0	25(5.5±1MHz)	600
LT6.0MB	6.000	fo±80	600	6.0	25(6.0±1MHz)	470
LT6.5MB	6.500	fo±80	630	6.0	25(6.5+1MHz) 30(6.5-1MHz)	470

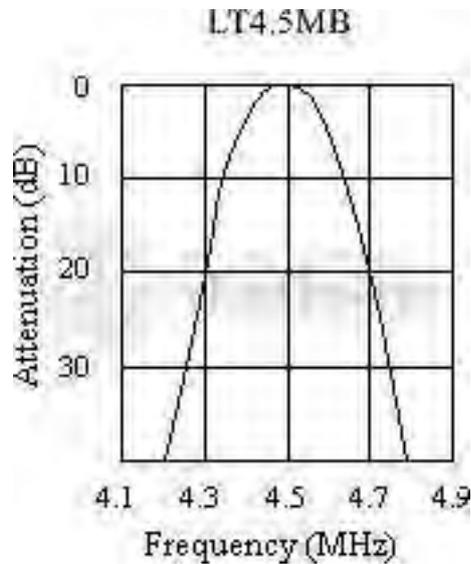

▶ Test Circuit

Test Circuit (LT MB)

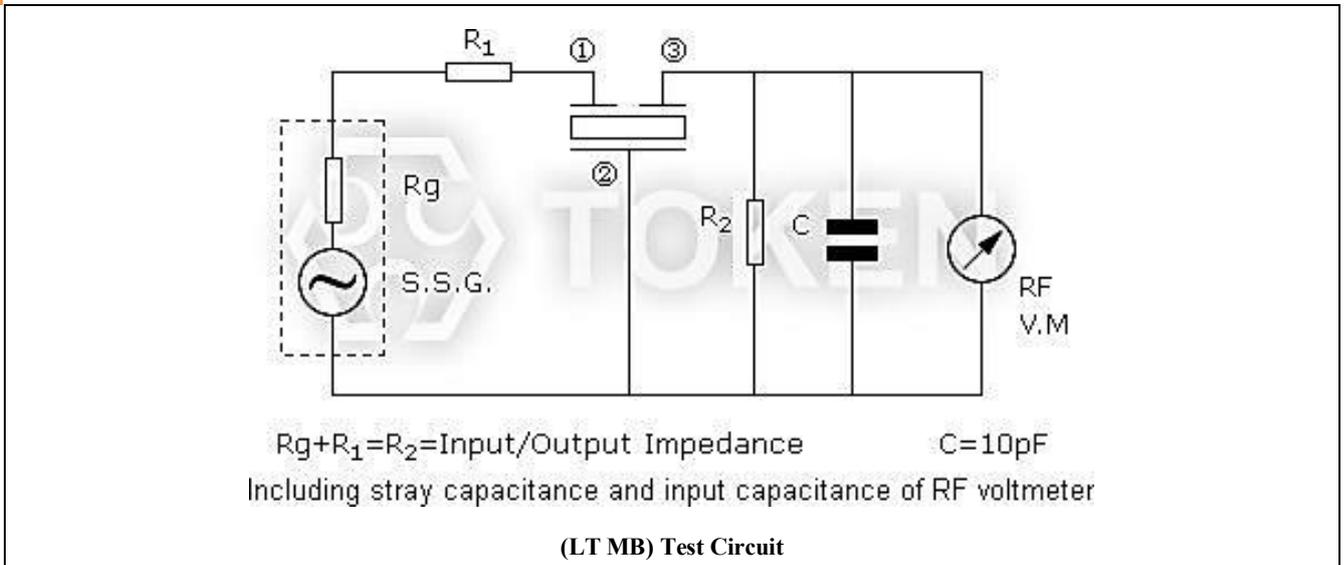

▶ Order Codes

Order Codes (LT MB)

LT5.5MB	P
Part Number	Package

▶ General Information

Introduction of Filters

For more than two decades, piezo technology has been instrumental in the proliferation of solid state electronics. A view of the future reveals that even greater expectations will be placed on piezoelectric material in the area of new applications and for more stringent performance criteria in modern products.

Token sophisticated ceramics technology has greatly increased selectivity and wide-band characteristics, and has stabilized the characteristics of ceramic filters. The series covers a wide range of attenuation and bandwidths to allow selection of the most optimum filter characteristics for each application.

Token filters are band pass filters consisting of one or more ceramic resonators connected in a ladder network configuration. Pass band characteristics are determined by the relative resonant and anti-resonant frequencies of the resonators. Both narrow and wide pass band configurations are manufactured by adjusting the resonator frequency characteristics.

The IC (Integrated Circuit) has found wide use in the field of commercial equipment, such as automotive radios, stereo systems, 2-way communications, TV sets, etc. Thus, new miniature integrated filters, with high performance, are extremely desirable for use in IF circuits.

Furthermore, radio wave disturbance due to rapid progress of data transmitting rate and remarkable sophistication of communication network have become significant traffic conflicts. Accordingly, the demand for filters with high selectivity and wide pass band width has boosted.

The IC application of the active elements will continue its progress, and there will be a growing demand for highly selective, non-adjustable, miniature and wide pass band width IF circuit.

Advantage of Token Piezoelectric Filters

Token Electronics had been able to develop specialized piezo materials which when combined with an advance design have resulted in a complete line of practical, inexpensive piezo devices for entertainment and communications applications.

Token reliably deliver high-quality components according to the each customer special needs with respect to performance, costs, and technology modifications.

For marketing discontinuations or sourcing activities concerning Piezoelectric Filter products, you are encouraged to contact our Sales Department so the request can be properly directed within Token.



Ceramic Filters (LTP)

▶ Product Introduction

Introduction (LTP)

Features :

- Center frequency range between 450~470kHz are available standard tolerance of ± 2 kHz.
- Insert Loss (dB) max 5.0 db.

Token Ceramic Filters for AM are Compatible Murata SFU450/455kHz. Token ceramic filters are primarily designed for piezoelectric lines and conform to the RoHS directive and Lead-free. Ceramic (LTP) filters for AM series are designed to address the needs of standard AM filtering requirements. These filters are recommended for use in low cost products where economically, efficient designs are critical.

The (LTP) series for AM use is one of the most recommendable intermediate filters, having such distinctive features as high selectivity, high stability, and adjustment-free operation. Additionally its easy matching with IC helps create an easy circuit design.

Token (LTP) filters can supply you high performance, high quality and stability. The (LTP) series can be customized designs and tighter tolerances available on request. Application of filters specific designs also available including different piezo band-pass devices and Q specifications adjusted to frequency requirements. Contact us with your specific needs. For more information, please link to Token official website "[Ceramic Filters](http://www.token.com.tw)".



► Dimensions

Dimensions (Unit: mm) (LTP)

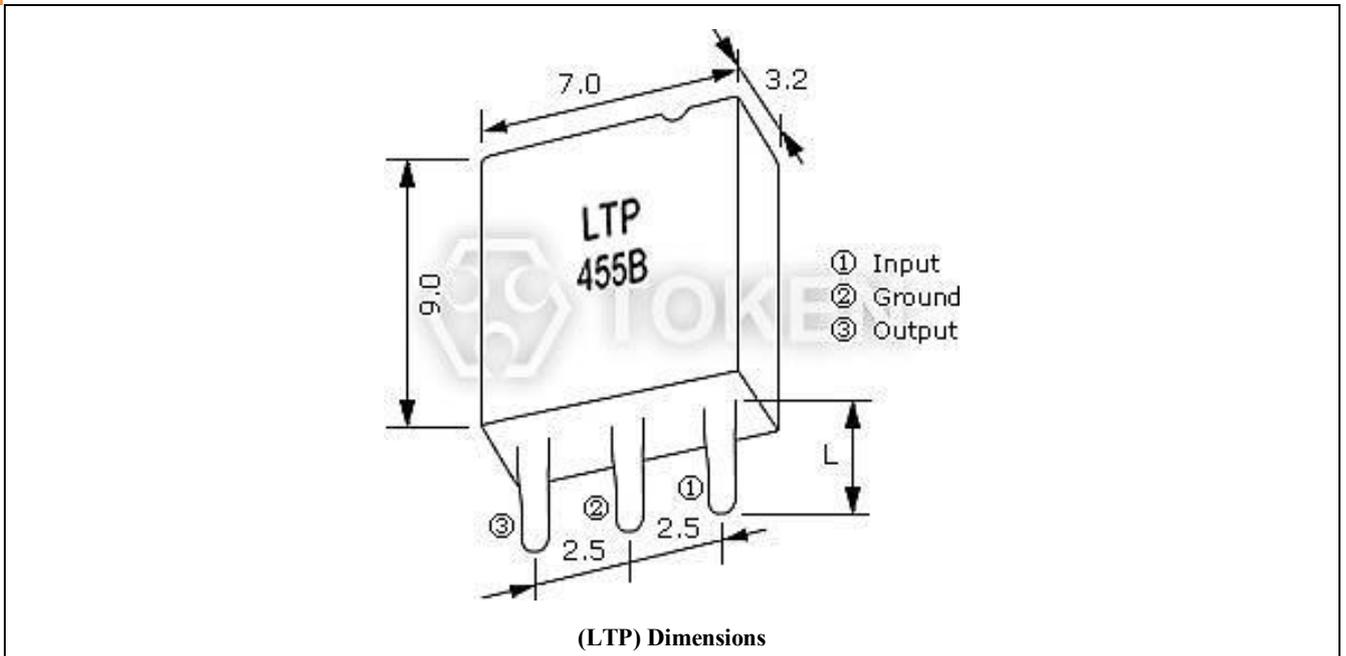

► Technical Characteristics

Technical Characteristics (LTP)

Part Number	3dB Band Width (kHz)	Center Frequency (fo) (kHz)	Selectivity (dB)min		Insert Loss (dB) max	Composition	Lead Length L (mm)	
			-9kHz off	+9kHz off			L1	L2
LTP455A	9.5±3	455±2	5.0	3.0	5.0	one element	3.6	5.0
LTP455B	9.5±3	462±2	5.0	3.0	5.0	one element with IFT		
LTP450BY	7±2	455±2	6.0	5.0	5.0			
LTP450BY1	4.5±1.5	452.5±2	9.0	8.0	5.0			

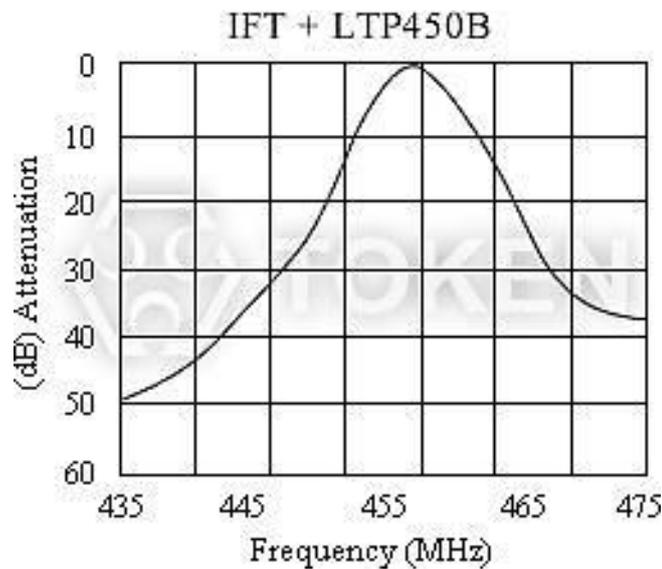

(LTP) Technical Characteristics

- Center Frequency (fo) is available in a range of 450~470kHz. The nominal frequency tolerance is ±2kHz.



▶ Recommended IFT

Recommended IFT (7mm Square) (LTP)

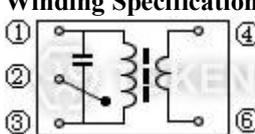
Item	LTP 455B		
Winding Specification	①~②	②~③	④~⑥
 Form bottom	70T	115T	7T
unloaded Qu	105		
Tuning Capacity	108PF		

▶ Test Circuit

Test Circuit (LTP)

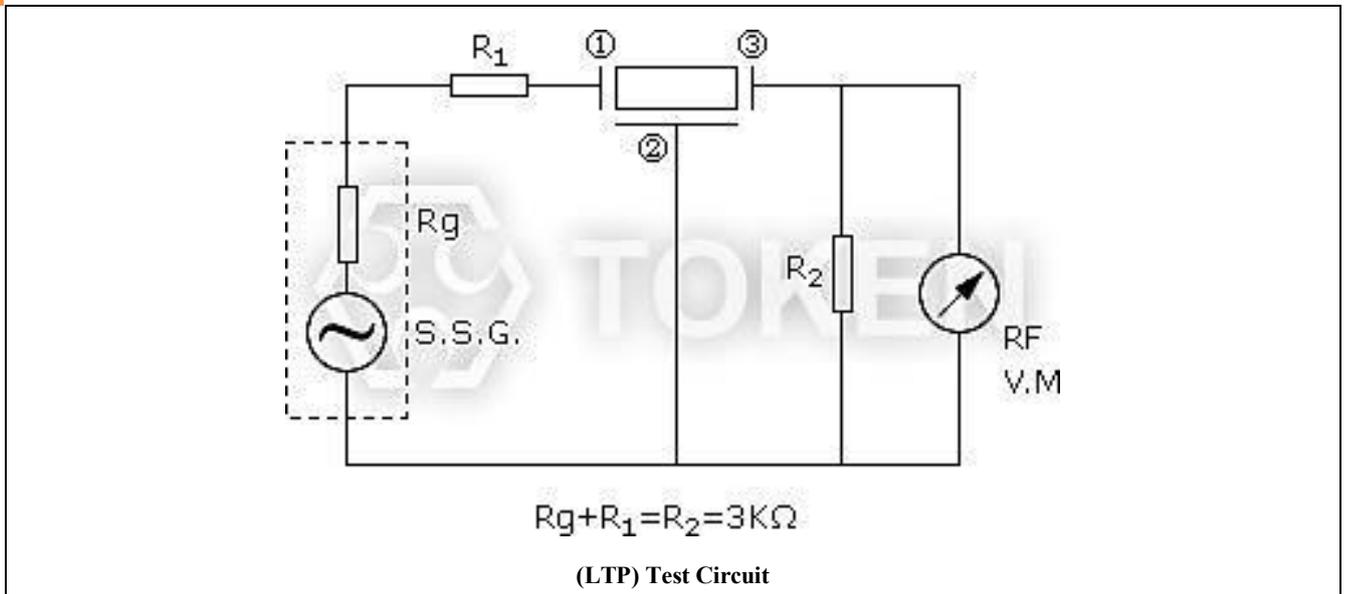

▶ Order Codes

Order Codes (LTP)

LTP455A	P
Part Number	Package

▶ General Information

Introduction of Filters

For more than two decades, piezo technology has been instrumental in the proliferation of solid state electronics. A view of the future reveals that even greater expectations will be placed on piezoelectric material in the area of new applications and for more stringent performance criteria in modern products.

Token sophisticated ceramics technology has greatly increased selectivity and wide-band characteristics, and has stabilized the characteristics of ceramic filters. The series covers a wide range of attenuation and bandwidths to allow selection of the most optimum filter characteristics for each application.

Token filters are band pass filters consisting of one or more ceramic resonators connected in a ladder network configuration. Pass band characteristics are determined by the relative resonant and anti-resonant frequencies of the resonators. Both narrow and wide pass band configurations are manufactured by adjusting the resonator frequency characteristics.

The IC (Integrated Circuit) has found wide use in the field of commercial equipment, such as automotive radios, stereo systems, 2-way communications, TV sets, etc. Thus, new miniature integrated filters, with high performance, are extremely desirable for use in IF circuits.

Furthermore, radio wave disturbance due to rapid progress of data transmitting rate and remarkable sophistication of communication network have become significant traffic conflicts. Accordingly, the demand for filters with high selectivity and wide pass band width has boosted.

The IC application of the active elements will continue its progress, and there will be a growing demand for highly selective, non-adjustable, miniature and wide pass band width IF circuit.

Advantage of Token Piezoelectric Filters

Token Electronics had been able to develop specialized piezo materials which when combined with an advance design have resulted in a complete line of practical, inexpensive piezo devices for entertainment and communications applications.

Token reliably deliver high-quality components according to the each customer special needs with respect to performance, costs, and technology modifications.

For marketing discontinuations or sourcing activities concerning Piezoelectric Filter products, you are encouraged to contact our Sales Department so the request can be properly directed within Token.



Ceramic Filters (LTS MCB/MDB)

► Product Introduction

Token (LTS MCB/MDB) Ceramic Filter is suitable for Multiplex Sound TV in America.

Token series ceramic filters low spurious for TV/VCR stage LTS MCB/MDB series use thickness shear vibration mode and is compatible Murata SFSH MCB/MDB. Features with excellent spurious characteristics within Video Signal Band, and 3 types' bandwidths prepared to respond customer requests. LTS MCB/MDB is suitable for Multiplex Sound TV in America.

The LTS MCB/MDB series conform to the RoHS directive and Lead-free. This filter low spurious for TV/VCR stage LTS MCB/MDB series can be customized designs and tighter tolerances available on request.



Application of filter specific designs also available including different piezo band-pass devices and Q specifications adjusted to frequency requirements. Token filters can supply you high performance, high quality and stability.

With dimensions max (10 × 8.0 × 4.0 mm), Insert Loss max 6dB, and Spurious Attenuation (0~fo) min 30dB, The LTS MCB/MDB has excellent spurious characteristics within Video Signal Band. Nominal Center Frequency (fo) is available with 4.500kHz, 5.500kHz, 6.000kHz, and 6.500kHz.

Custom parts are available on request. Token will also produce devices outside these specifications to meet specific customer requirements, please contact our sales or link to Token official website "[Ceramic Filters](#)" for more information.

► Dimensions

Dimensions (Unit: mm) (LTS MCB/MDB)

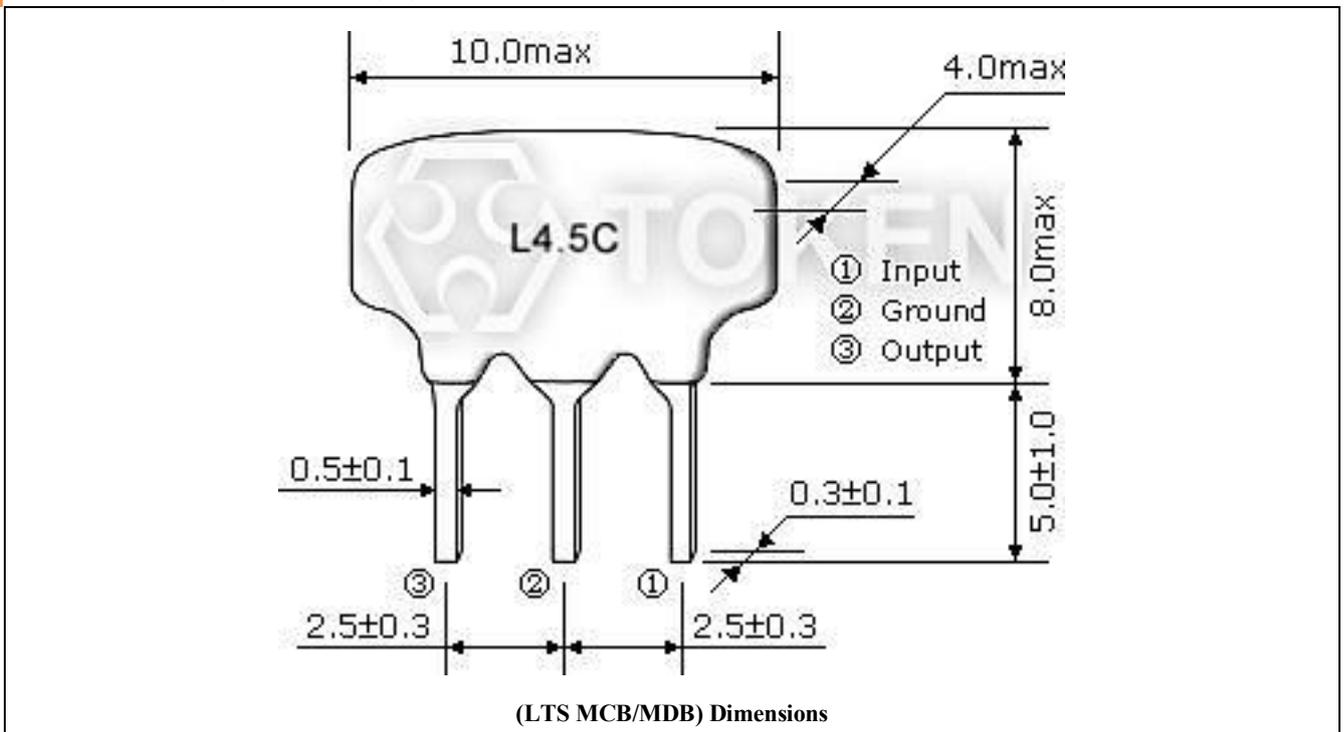

► Technical Characteristics

Technical Characteristics (LTS MCB/MDB)

Part Number	Nominal Center Frequency (fo) (MHz)	3dB Band Width (kHz) min	20dB Band Width (kHz) max	Insert Loss (dB) max	Spurious Attenuation (0~fo) (dB) min	Input/Output Impedance(Ω)
LTS4.5MCB	4.500	fo±60	600	6.0	30	1000
LTS4.5MDB	4.500	fo±70	750	6.0	30	1000
LTS5.5MCB	5.500	fo±60	600	6.0	30	600
LTS5.5MDB	5.500	fo±80	750	6.0	30	600
LTS6.0MCB	6.000	fo±60	600	6.0	30	470
LTS6.0MDB	6.000	fo±80	750	6.0	30	470
LTS6.5MCB	6.500	fo±70	650	6.0	30	470
LTS6.5MDB	6.500	fo±80	800	6.0	30	470

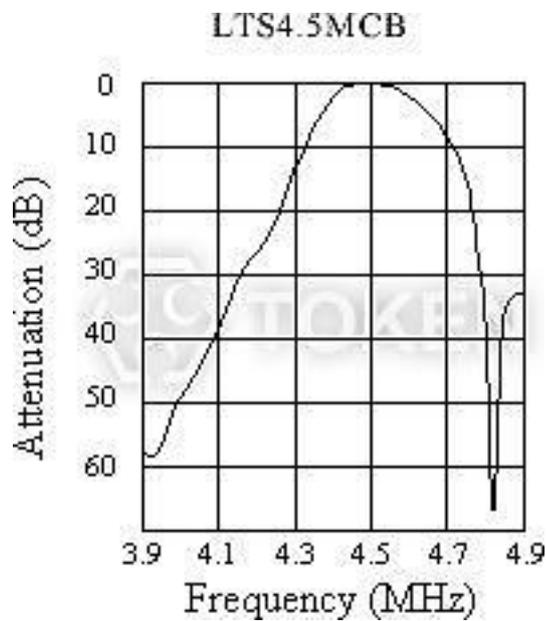

▶ Test Circuit

Test Circuit (LTS MCB/MDB)

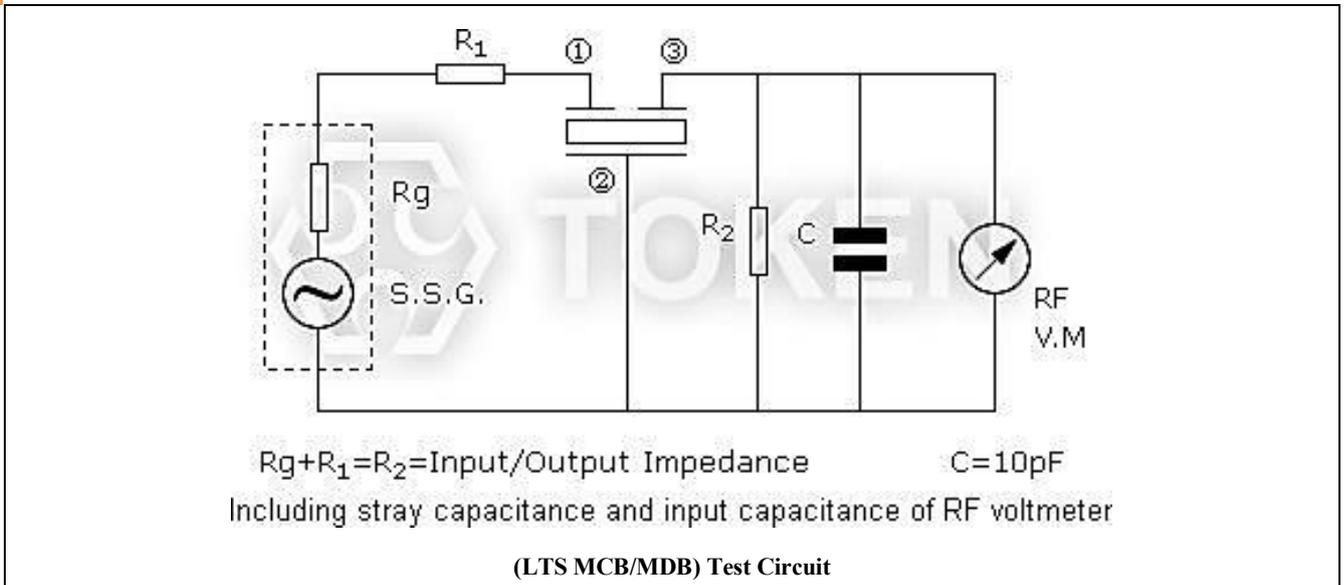

▶ Order Codes

Order Codes (LTS MCB/MDB)

LTS4.5MCB	P
Part Number	Package

▶ General Information

Introduction of Filters

For more than two decades, piezo technology has been instrumental in the proliferation of solid state electronics. A view of the future reveals that even greater expectations will be placed on piezoelectric material in the area of new applications and for more stringent performance criteria in modern products.

Token sophisticated ceramics technology has greatly increased selectivity and wide-band characteristics, and has stabilized the characteristics of ceramic filters. The series covers a wide range of attenuation and bandwidths to allow selection of the most optimum filter characteristics for each application.

Token filters are band pass filters consisting of one or more ceramic resonators connected in a ladder network configuration. Pass band characteristics are determined by the relative resonant and anti-resonant frequencies of the resonators. Both narrow and wide pass band configurations are manufactured by adjusting the resonator frequency characteristics.

The IC (Integrated Circuit) has found wide use in the field of commercial equipment, such as automotive radios, stereo systems, 2-way communications, TV sets, etc. Thus, new miniature integrated filters, with high performance, are extremely desirable for use in IF circuits.

Furthermore, radio wave disturbance due to rapid progress of data transmitting rate and remarkable sophistication of communication network have become significant traffic conflicts. Accordingly, the demand for filters with high selectivity and wide pass band width has boosted.

The IC application of the active elements will continue its progress, and there will be a growing demand for highly selective, non-adjustable, miniature and wide pass band width IF circuit.

Advantage of Token Piezoelectric Filters

Token Electronics had been able to develop specialized piezo materials which when combined with an advance design have resulted in a complete line of practical, inexpensive piezo devices for entertainment and communications applications.

Token reliably deliver high-quality components according to the each customer special needs with respect to performance, costs, and technology modifications.

For marketing discontinuations or sourcing activities concerning Piezoelectric Filter products, you are encouraged to contact our Sales Department so the request can be properly directed within Token.



High-Selectivity Band-Pass Filters (LTT MA)

▶ Product Introduction

Ceramic High-Selectivity Band-Pass Filter for TV/VCR Stage Compatible Murata SFT.

Token high-selectivity filters for TV/VCR stage (LTT MA) series is 4 element devices that offer more selectivity than the conventional LT series (Murata SFE). The improved spurious suppression of these filters eliminates the need for cascading multiple filtering devices; therefore, it is possible to design a more compact circuit board configuration.

Token High-Selectivity (LTT MA) Band-Pass Filter conforms to the RoHS directive. This high-selectivity device can be customized designs and tighter tolerances available on request.



Application of ceramic filter specific designs also available including different piezo band-pass devices and Q specifications adjusted to frequency requirements. Token ceramic filters can supply you high performance, high quality and stability.

With dimensions ($15\pm 2.0 \times 7.5\pm 2.0 \times 3.0\pm 1.0$ mm), Insert Loss max 9dB and 10dB, Spurious Attenuation min 40dB and 50 dB, and Input/Output Impedance 470 Ω , 600 Ω , 1000 Ω , Nominal Center Frequency (f_0) (MHz) of LTT MA series is available 4.500MHz, 4.724MHz, 5.500MHz, 5.742MHz, 6.000MHz, 6.250MHz, 6.500MHz, and 6.742MHz.

Custom parts are available on request. Token will also produce devices outside these specifications to meet specific customer requirements, please contact our sales or link to Token official website "[Ceramic Filters](#)" for more information.

► Dimensions

Dimensions (Unit: mm) (LTT MA)

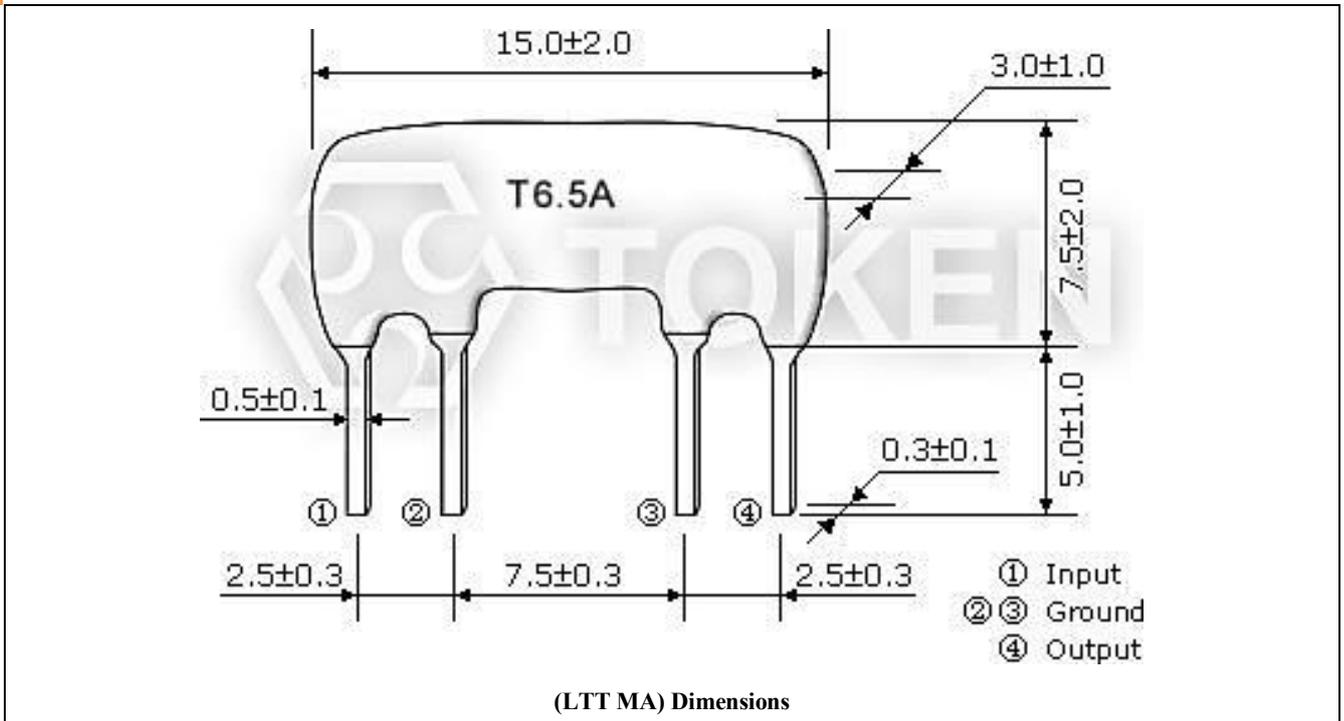

► Technical Characteristics

Technical Characteristics (LTT MA)

Part Number	Nominal Center Frequency (fo) (MHz)	3dB Band Width (kHz) min	20dB Band Width (kHz) max	Insert Loss (dB) max	Spurious Attenuation (dB) min	Input/Output Impedance (Ω)
LTT4.5MA	4.500	fo±40	370	10.0	40(4.5 ^{+0.8} _{-1.0} MHz)	1000
LTT4.72MA	4.724	fo±40	370	10.0	40(4.72 ^{+0.8} _{-1.0} MHz)	1000
LTT5.5MA	5.500	fo±50	350	9.0	40(5.5±1MHz)	600
LTT5.74MA	5.742	fo±50	350	9.0	50(5.74±1MHz)	600
LTT6.0MA	6.000	fo±50	400	9.0	50(6.0±1MHz)	470
LTT6.25MA	6.250	fo±50	400	9.0	50(6.25±1MHz)	470
LTT6.5MA	6.500	fo±50	400	9.0	50(6.5±1MHz)	470
LTT6.74MA	6.742	fo±50	400	9.0	50(6.74±1MHz)	470

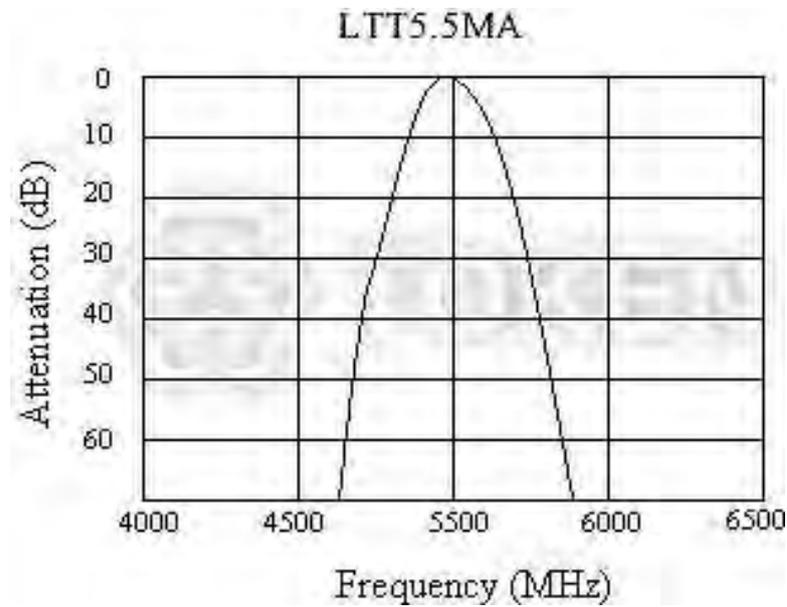

▶ Test Circuit

Test Circuit (LTT MA)

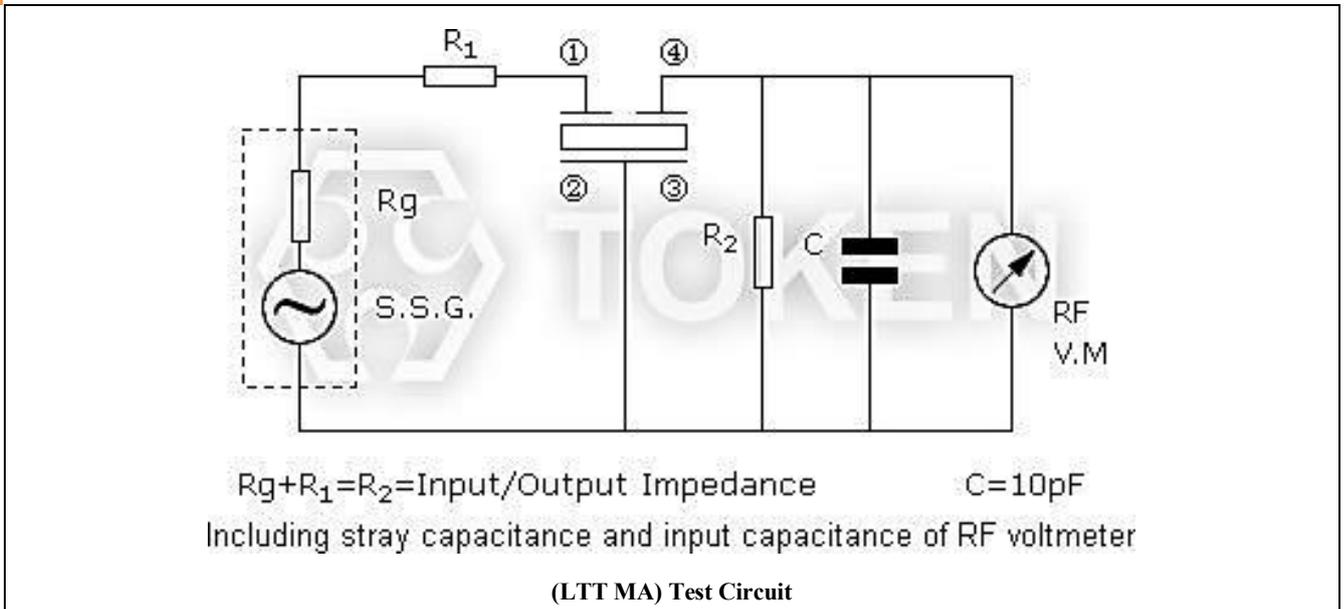

▶ Order Codes

Order Codes (LTT MA)

LTT4.5MA	P
Part Number	Package

▶ General Information

Introduction of Filters

For more than two decades, piezo technology has been instrumental in the proliferation of solid state electronics. A view of the future reveals that even greater expectations will be placed on piezoelectric material in the area of new applications and for more stringent performance criteria in modern products.

Token sophisticated ceramics technology has greatly increased selectivity and wide-band characteristics, and has stabilized the characteristics of ceramic filters. The series covers a wide range of attenuation and bandwidths to allow selection of the most optimum filter characteristics for each application.

Token filters are band pass filters consisting of one or more ceramic resonators connected in a ladder network configuration. Pass band characteristics are determined by the relative resonant and anti-resonant frequencies of the resonators. Both narrow and wide pass band configurations are manufactured by adjusting the resonator frequency characteristics.

The IC (Integrated Circuit) has found wide use in the field of commercial equipment, such as automotive radios, stereo systems, 2-way communications, TV sets, etc. Thus, new miniature integrated filters, with high performance, are extremely desirable for use in IF circuits.

Furthermore, radio wave disturbance due to rapid progress of data transmitting rate and remarkable sophistication of communication network have become significant traffic conflicts. Accordingly, the demand for filters with high selectivity and wide pass band width has boosted.

The IC application of the active elements will continue its progress, and there will be a growing demand for highly selective, non-adjustable, miniature and wide pass band width IF circuit.

Advantage of Token Piezoelectric Filters

Token Electronics had been able to develop specialized piezo materials which when combined with an advance design have resulted in a complete line of practical, inexpensive piezo devices for entertainment and communications applications.

Token reliably deliver high-quality components according to the each customer special needs with respect to performance, costs, and technology modifications.

For marketing discontinuations or sourcing activities concerning Piezoelectric Filter products, you are encouraged to contact our Sales Department so the request can be properly directed within Token.



Ceramic Filters (LTZ)

▶ Product Introduction

Introduction (LTZ)

The Low Cost Standard AM Filters (Murata SFZ Compatible). Ceramic filters for AM (LTZ) series are designed to address the needs of standard AM filtering requirements and are recommended for use in low cost products where economically, efficient designs are critical.

Token ceramic filters LTZ series for AM conform to the RoHS directive. The LTZ series can be customized designs and tighter tolerances available on request.

Application of ceramic filters specific designs also available including different piezo band-pass devices and Q specifications adjusted to frequency requirements. Token ceramic filters can supply you high performance, high quality and stability.

With dimensions (7.0 × 9.0 × 6.5mm), and Insertion Loss 7db, the (LTZ) series is composition of 2 elements direct coupling. Center Frequency (f_0) is available in a range of 450kHz ~ 470kHz. The nominal frequency tolerance is ± 2 kHz.

Custom parts are available on request. Token will also produce devices outside these specifications to meet specific customer requirements, please contact our sales or link to Token official website "[Ceramic Filters](#)" for more information.



► Dimensions

Dimensions (Unit: mm) (LTZ)

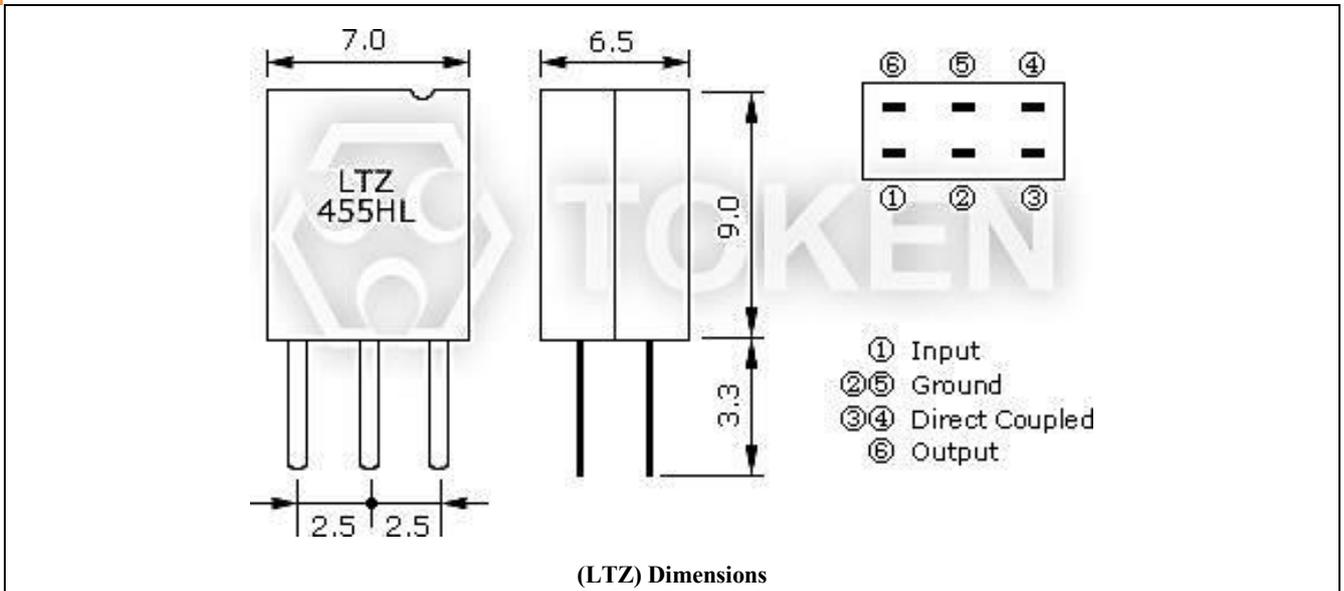

► Technical Characteristics

Technical Characteristics (LTZ)

Part Number	Center Frequency (fo) (kHz)	3dB Band Width (kHz)	Selectivity $\pm 9\text{kHz off (dB) min}$	Insertion Loss (dB)	Composition
LTZ455HL	455.5 \pm 2.0	4.0 \pm 1	23	7	2 elements direct coupling type
LTZ455JL	456.0 \pm 2.0	5.5 \pm 1	18	7	

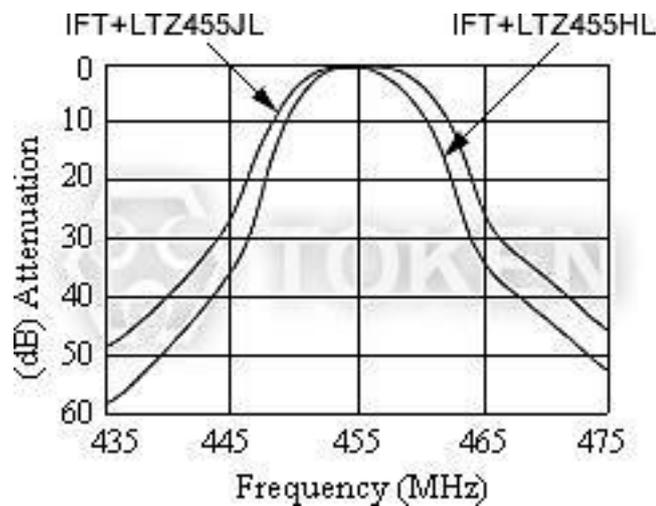

(LTZ) Technical Characteristics

- Center Frequency (fo) is available in a range of 450 ~ 470kHz. The nominal frequency tolerance is $\pm 2\text{kHz}$.

▶ Test Circuit

Test Circuit (LTZ)

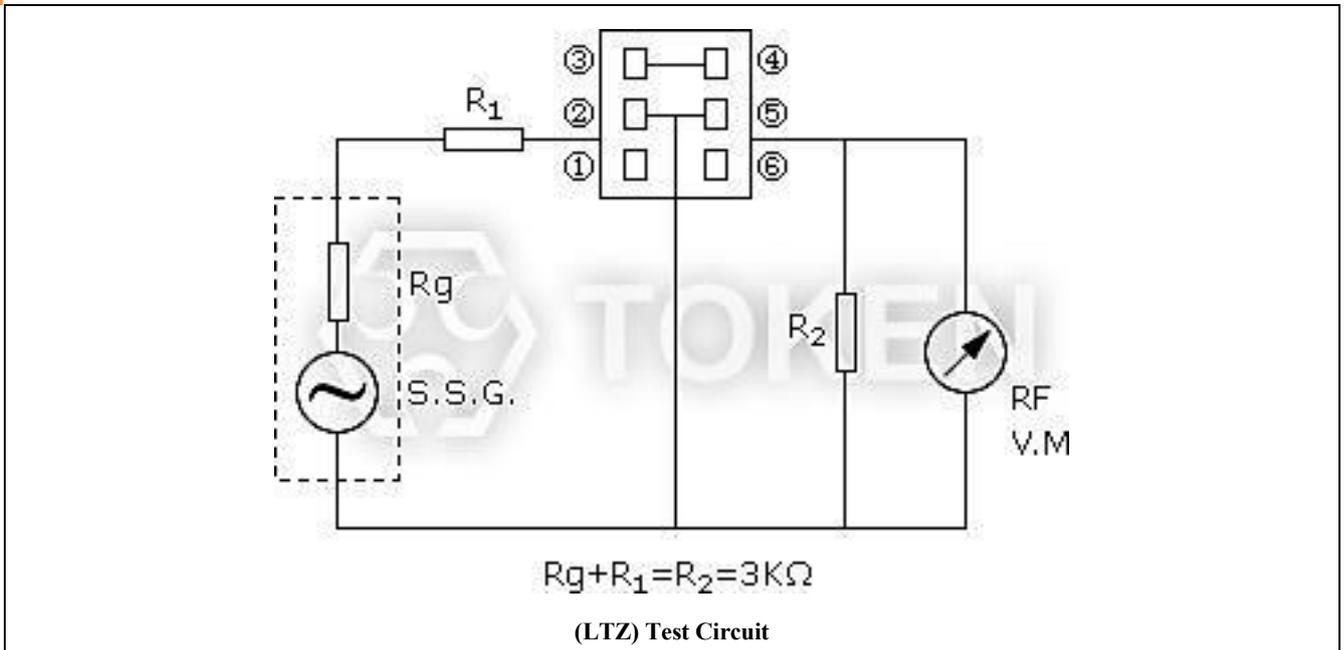

▶ Recommended IFT

Recommended IFT (7mm Square) (LTZ)

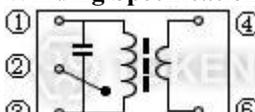
Item	LTZ455HL/JL		
Winding Specification	①~②	②~③	④~⑥
 Form bottom	68T	84T	14T
unloaded Qu	90		
Tuning Capacity	108PF		

▶ Order Codes

Order Codes (LTZ)

LTZ455HL	P
Part Number	Package

► General Information

Introduction of Filters

For more than two decades, piezo technology has been instrumental in the proliferation of solid state electronics. A view of the future reveals that even greater expectations will be placed on piezoelectric material in the area of new applications and for more stringent performance criteria in modern products.

Token sophisticated ceramics technology has greatly increased selectivity and wide-band characteristics, and has stabilized the characteristics of ceramic filters. The series covers a wide range of attenuation and bandwidths to allow selection of the most optimum filter characteristics for each application.

Token filters are band pass filters consisting of one or more ceramic resonators connected in a ladder network configuration. Pass band characteristics are determined by the relative resonant and anti-resonant frequencies of the resonators. Both narrow and wide pass band configurations are manufactured by adjusting the resonator frequency characteristics.

The IC (Integrated Circuit) has found wide use in the field of commercial equipment, such as automotive radios, stereo systems, 2-way communications, TV sets, etc. Thus, new miniature integrated filters, with high performance, are extremely desirable for use in IF circuits.

Furthermore, radio wave disturbance due to rapid progress of data transmitting rate and remarkable sophistication of communication network have become significant traffic conflicts. Accordingly, the demand for filters with high selectivity and wide pass band width has boosted.

The IC application of the active elements will continue its progress, and there will be a growing demand for highly selective, non-adjustable, miniature and wide pass band width IF circuit.

Advantage of Token Piezoelectric Filters

Token Electronics had been able to develop specialized piezo materials which when combined with an advance design have resulted in a complete line of practical, inexpensive piezo devices for entertainment and communications applications.

Token reliably deliver high-quality components according to the each customer special needs with respect to performance, costs, and technology modifications.

For marketing discontinuations or sourcing activities concerning Piezoelectric Filter products, you are encouraged to contact our Sales Department so the request can be properly directed within Token.



Narrow Bandwidth Filters (LZU)

▶ Product Introduction

Introduction (LZU)

Features :

- Center frequency: 455kHz. (470kHz is also available.)
- Most suitable for IC Station Detectors (SD).
- Resonant Resistance (max): $20\Omega \sim 30\Omega$.
- LZU Dimensions: (7.0 × 9.0 × 3.5 mm).
- for IF signal detection.

Search-Stop Signal Detection Narrow Bandwidth Filters 450 kHz, (Murata BFULA Compatible). Token ceramic filters 450 kHz search-stop signal detection (LZU) series are specifically designed for signal detection circuitry used in applications such as that found in the search-stop functions of electronically tuned radios. Center frequency is also available in LTZ series a range of 450 kHz ~ 470kHz.

The (LZU) series are narrow bandwidth filters. This filter is used in the application which detects the carrier peak with a narrow bandwidth amplifier, or an electronic tuner as a stop signal detector.

The (LZU) series can be customized designs and tighter tolerances available on request and conform to the RoHS directive.

Custom parts are available on request. Token will also produce devices outside these specifications to meet specific customer requirements, please contact our sales or link to Token official website "[Ceramic Filters](#)" for more information.



► Dimensions

Dimensions (Unit: mm) (LZU)

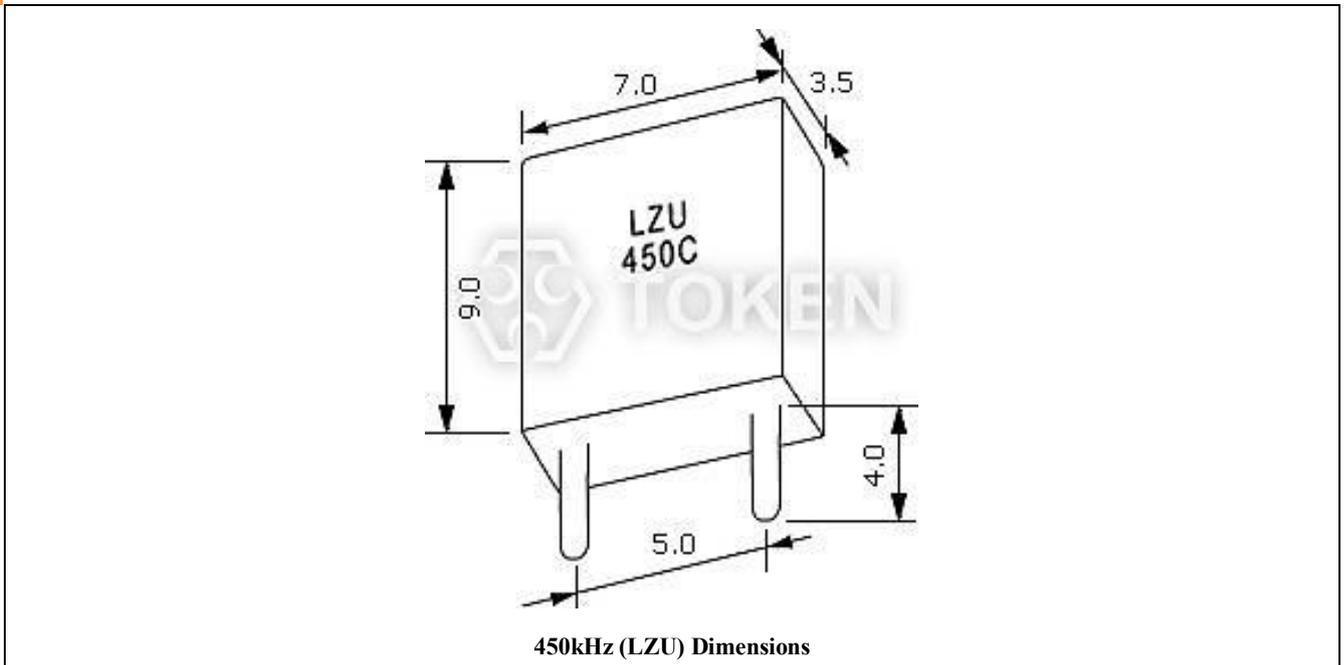

► Technical Characteristics

Technical Characteristics (LZU)

Part Number	Resonant Frequency (kHz)	Resonant Resistance (Ω) (max)	Band Width(fa-fr) (kHz)	Application
LZU450C	450 \pm 1.0	20	14 \pm 2	IF signal detection
LZU450C4N	450 \pm 0.8	30	9 \pm 2	
LZU450K3	450 \pm 1.0	30	27.5 \pm 4.5	

▶ **Technical Test Circuit**

Test Circuit (LZU)

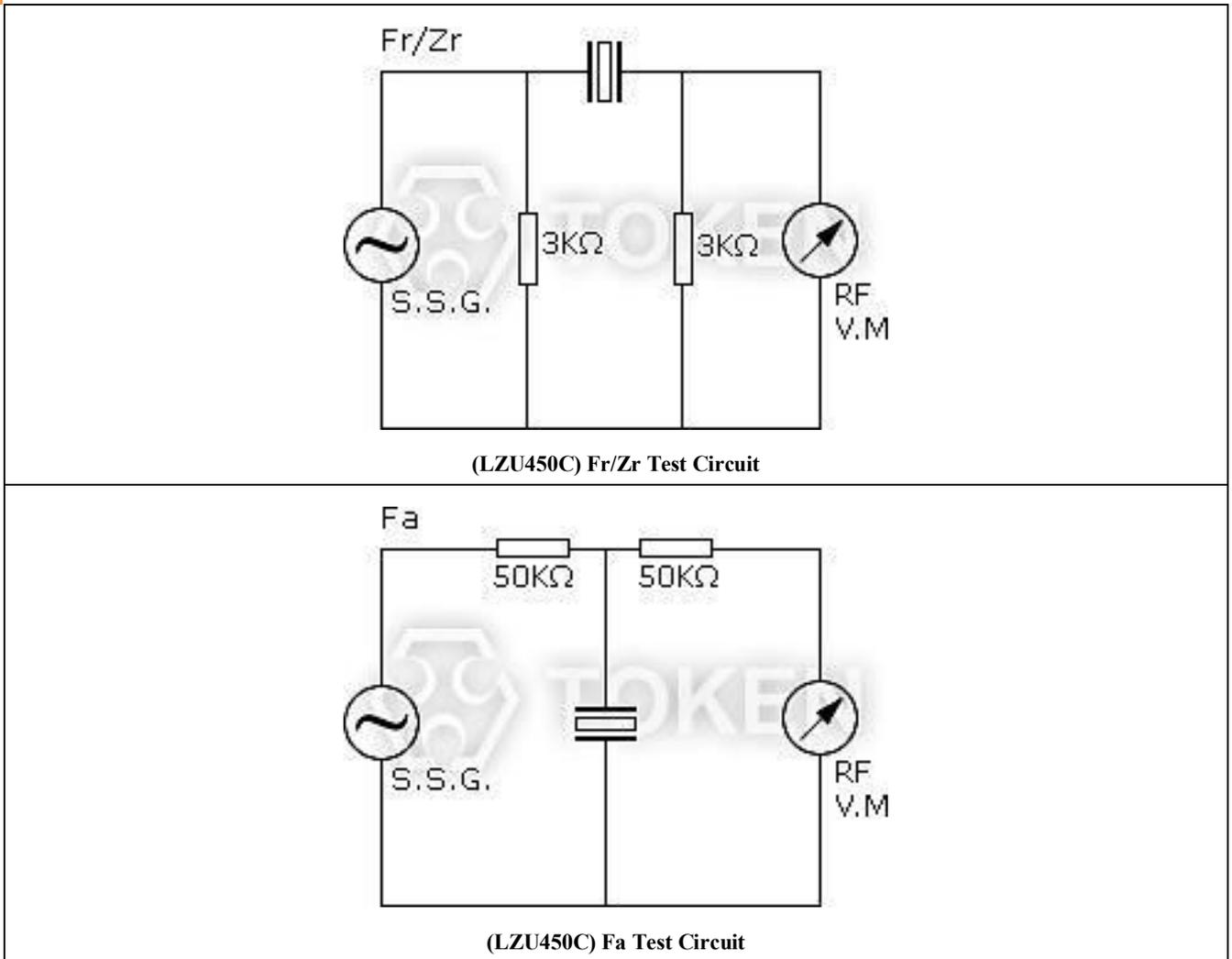

▶ **Order Codes**

Order Codes (LZU)

LZU450C	P
Part Number	Package

▶ General Information

Introduction of Filters

For more than two decades, piezo technology has been instrumental in the proliferation of solid state electronics. A view of the future reveals that even greater expectations will be placed on piezoelectric material in the area of new applications and for more stringent performance criteria in modern products.

Token sophisticated ceramics technology has greatly increased selectivity and wide-band characteristics, and has stabilized the characteristics of ceramic filters. The series covers a wide range of attenuation and bandwidths to allow selection of the most optimum filter characteristics for each application.

Token filters are band pass filters consisting of one or more ceramic resonators connected in a ladder network configuration. Pass band characteristics are determined by the relative resonant and anti-resonant frequencies of the resonators. Both narrow and wide pass band configurations are manufactured by adjusting the resonator frequency characteristics.

The IC (Integrated Circuit) has found wide use in the field of commercial equipment, such as automotive radios, stereo systems, 2-way communications, TV sets, etc. Thus, new miniature integrated filters, with high performance, are extremely desirable for use in IF circuits.

Furthermore, radio wave disturbance due to rapid progress of data transmitting rate and remarkable sophistication of communication network have become significant traffic conflicts. Accordingly, the demand for filters with high selectivity and wide pass band width has boosted.

The IC application of the active elements will continue its progress, and there will be a growing demand for highly selective, non-adjustable, miniature and wide pass band width IF circuit.

Advantage of Token Piezoelectric Filters

Token Electronics had been able to develop specialized piezo materials which when combined with an advance design have resulted in a complete line of practical, inexpensive piezo devices for entertainment and communications applications.

Token reliably deliver high-quality components according to the each customer special needs with respect to performance, costs, and technology modifications.

For marketing discontinuations or sourcing activities concerning Piezoelectric Filter products, you are encouraged to contact our Sales Department so the request can be properly directed within Token.



Ceramic Miniature Filter (MLT)

▶ Product Introduction

Introduction (MLT)

One of The Most Recommendable Intermediate Filters for AM (Murata PFB Compatible). Token miniature ceramic filters for AM are one of the most recommendable intermediate filters, having such distinctive features as high selectivity, high stability and adjustment-free operation.

Additionally its easy matching with IC helps create an easy circuit design such as applications in Electric synthesized tuners, HiFi audio systems, AM stereo demodulations, One-chip non-adjustment IC's, and even smaller, thinner set structure to cope with these diversifying for AM receiver.

Features with center frequency between 450 and 470 kHz, standard tolerance ± 2 kHz, and synthesizers for the types of center frequencies 450, 459 and 468 kHz. Standard tolerance is ± 1 kHz.

Contact us with your specific needs. For more information, please link to Token official website "[Ceramic Filters](#)".



► Dimensions

Dimensions (Unit: mm) (MLT)

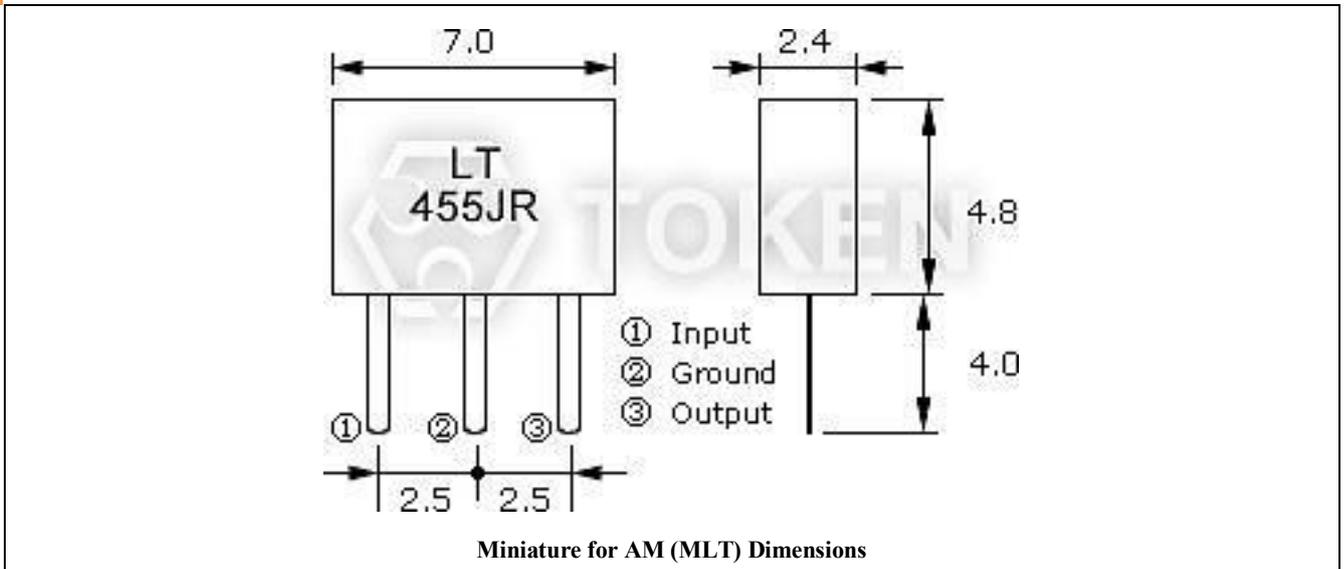

► Technical Characteristics

Technical Characteristics (MLT)

Part Number	3dB Band Width (kHz)	Selectivity ± 9 kHz off (dB)	Insertion Loss (dB)	Composition
LT 455JR	5.5 \pm 1.5	≥ 17	≤ 6	2 elements

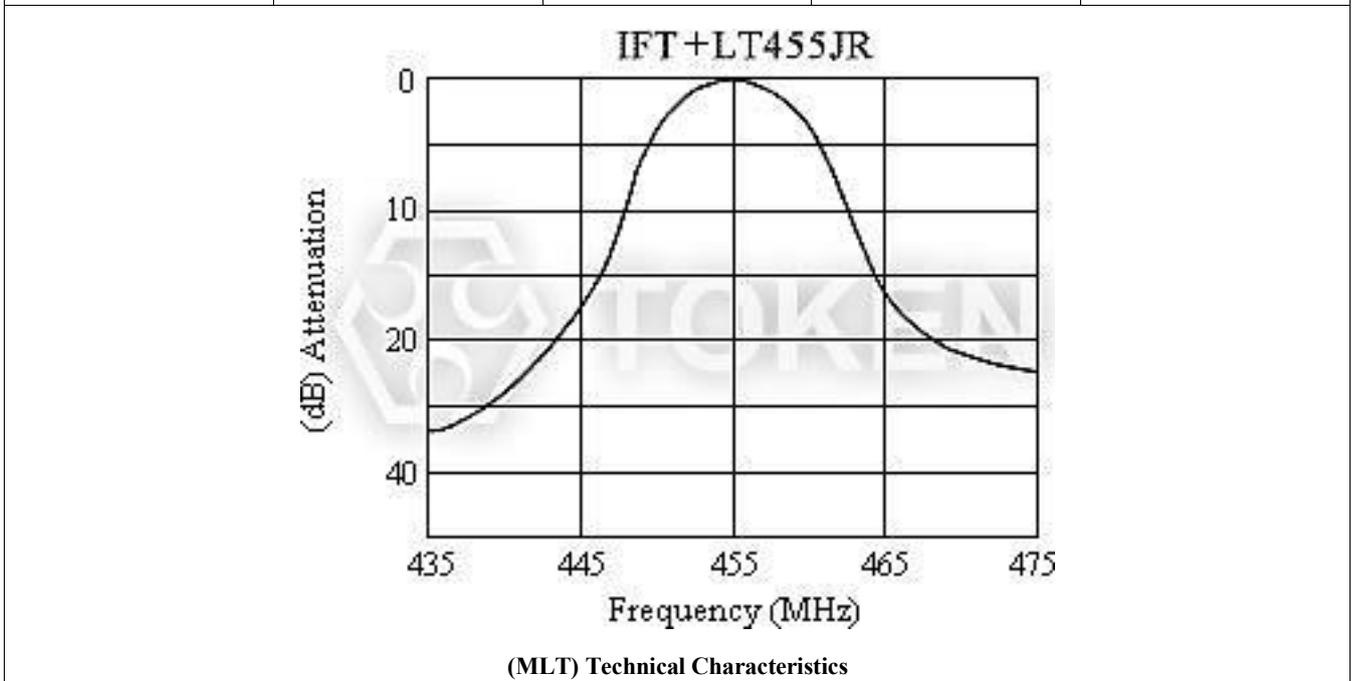

- Center Frequency (f_0) is available in a range of 450 ~ 470kHz.
The nominal frequency tolerance is ± 2 kHz.

▶ Recommended IFT

Recommended IFT (MLT)

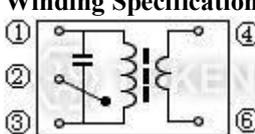
Item	7×7mm			5×5mm		
Winding Specification  Form bottom	①~②	②~③	④~⑥	①~②	②~③	④~⑥
	85T	67T	23T	84T	98T	33T
unloaded Qu	90			65		
Tuning Capacity	180PF			180PF		

▶ Order Codes

Order Codes (MLT)

LT 455JR	P
Part Number	Package

▶ General Information

Introduction of Filters

For more than two decades, piezo technology has been instrumental in the proliferation of solid state electronics. A view of the future reveals that even greater expectations will be placed on piezoelectric material in the area of new applications and for more stringent performance criteria in modern products.

Token sophisticated ceramics technology has greatly increased selectivity and wide-band characteristics, and has stabilized the characteristics of ceramic filters. The series covers a wide range of attenuation and bandwidths to allow selection of the most optimum filter characteristics for each application.

Token filters are band pass filters consisting of one or more ceramic resonators connected in a ladder network configuration. Pass band characteristics are determined by the relative resonant and anti-resonant frequencies of the resonators. Both narrow and wide pass band configurations are manufactured by adjusting the resonator frequency characteristics.

The IC (Integrated Circuit) has found wide use in the field of commercial equipment, such as automotive radios, stereo systems, 2-way communications, TV sets, etc. Thus, new miniature integrated filters, with high performance, are extremely desirable for use in IF circuits.

Furthermore, radio wave disturbance due to rapid progress of data transmitting rate and remarkable sophistication of communication network have become significant traffic conflicts. Accordingly, the demand for filters with high selectivity and wide pass band width has boosted.

The IC application of the active elements will continue its progress, and there will be a growing demand for highly selective, non-adjustable, miniature and wide pass band width IF circuit.

Advantage of Token Piezoelectric Filters

Token Electronics had been able to develop specialized piezo materials which when combined with an advance design have resulted in a complete line of practical, inexpensive piezo devices for entertainment and communications applications.

Token reliably deliver high-quality components according to the each customer special needs with respect to performance, costs, and technology modifications.

For marketing discontinuations or sourcing activities concerning Piezoelectric Filter products, you are encouraged to contact our Sales Department so the request can be properly directed within Token.

