

Version:  
February 24, 2017



# Ceramic Resonator Series

## **Token Electronics Industry Co., Ltd.**

**Taiwan:** No.137, Sec. 1, Zhongxing Rd., Wugu District,  
New Taipei City, Taiwan, R.O.C. 24872  
Tel: +886 2981 0109 Fax: +886 2988 7487

**China:** 12F, Zhong Xing Industry Bld., Chuang Ye Road,  
Nan Shan District, Shen Zhen City,  
Guang Dong, China 518054  
Tel: +86 755 26055363; Fax: +86 755 26055365

[Web: www.token.com.tw](http://www.token.com.tw)

[Email: rfq@token.com.tw](mailto:rfq@token.com.tw)



## Production Index

### Ceramic Resonator Series

Applications & Notice .....	1
Applications & Notice .....	1
Crystal VS Ceramics .....	2
Crystal VS Ceramics .....	2
Quartz Crystal Resonators (TACA) .....	4
Product Introduction .....	4
Dimensions .....	5
Electrical Spec. ....	6
Peeling Strength .....	6
Land Pattern .....	7
Reflow Soldering .....	7
Packing & Reel .....	8
Carrier Tape.....	9
Order Codes .....	9
General Information.....	10
Ceramic Resonators (ZTA) .....	11
Product Introduction .....	11
Dimensions .....	12
Technical Characteristics .....	13
Oscillation Circuit for MOS IC.....	14
Order Codes .....	15
General Information.....	15
Ceramic Resonators (ZTB) .....	16
Product Introduction .....	16
Dimensions .....	17
Technical Characteristics .....	18
Test Circuit for MOS IC.....	19
Order Codes .....	20
General Information.....	20
Ceramic Resonators (ZTB456/500/503/912F).....	21
Product Introduction .....	21
Dimensions .....	22
Technical Characteristics .....	23
Order Codes .....	24
General Information.....	24
Surface Mountable Resonators (ZTBY) .....	25
Product Introduction .....	25
Dimensions .....	26
Technical Characteristics .....	26
Test Circuit for MOS IC.....	27
Order Codes .....	28
General Information.....	28
Ceramic Resonators (ZTT) .....	29
Product Introduction .....	29



Dimensions .....	30
Technical Characteristics .....	31
Test Circuit for MOS IC.....	32
Order Codes .....	33
General Information.....	33
<b>SMD Ceramic Resonators (ZTAC/ZTTC).....</b>	<b>34</b>
Product Introduction .....	34
ZTAC Dimensions .....	35
ZTTC Dimensions .....	36
Technical Characteristics .....	37
Test Circuit for MOS IC.....	38
Recommended Land Pattern .....	39
Order Codes .....	40
General Information.....	40



# Applications & Notice

## ► Applications & Notice

### Applications & Notice

#### Design Notice

##### Operating Temperature Ranges

The resonators should not be operated beyond the Operating Temperature Range specified in the catalog.

##### Changes/Drifts in Oscillating Frequency

Oscillating frequency may drift depending upon the controlling IC and/or external capacitors  $C_1$  and  $C_2$  used in the circuit design.

Token standard resonator is adjusted with our standard measuring circuit. There could be slight shift in frequency other types of IC are used. When you require exact oscillation frequency in your application, we can adjust it with your specified circuit on request.

##### Fail-Safe Design for Equipment

When using the resonators, it is recommended that you build a protective failsafe circuit into your design to prevent equipment damage in the event that the resonator malfunctions or fails.

##### Abnormal Oscillation

The resonators are always accompanied by spurious resonances. Spurious oscillations or stoppage of oscillation may occur depending on the circuit design (IC used, frequency characteristics of the IC, supply voltage etc.) and/or environmental conditions. These factors should be taken into consideration when designing the circuit.

##### Stray Capacitance

Stray capacitances and insulation resistances on printed circuit boards may cause abnormal oscillation or stoppage of oscillation. These factors should be taken into consideration when designing the circuit.

##### Overvoltage Spikes & Electrostatic Discharges

Voltage spikes and electrostatic discharges may cause damage/malfunction or failures of the resonators.

##### Abnormal Mechanical Stresses

Abnormal or excess mechanical stresses such as vibration or shock should be avoided when handling or storing resonators to prevent damage and cracking.

##### Surface Mounting Consideration

In automated mounting of The resonators on printed circuit boards, any bending, expanding and pulling forces or shocks to the resonator should be kept to a minimum to prevent electrical failures and/or mechanical damage to the devices.

##### Prohibited Applications

- Flow Soldering should not be used to solder resonators.
- Please do not apply excess mechanical stress to the component and lead terminals at soldering.
- Ultrasonic Cleaning and Ultrasonic Welding should not be used on resonators to avoid possible damage.
- Avoid washing in water because it could deteriorate the resonator's performance characteristics.
- Avoid resin coating or potting for humidity protection because it could deteriorate the resonator's performance characteristics.



# Crystal VS Ceramics

## ▶ Crystal VS Ceramics

### Crystal VS Ceramics

The majority of clock sources for microcontrollers can be grouped into two types: those based on mechanical resonant devices, such as crystals and ceramics, and those based on electrical phase-shift circuits such as RC (resistor, capacitor) oscillators. Ceramic and crystal resonator-based oscillators (mechanical) typically provide very high initial accuracy and a moderately low temperature coefficient.

Power consumption is another important consideration of oscillator selection. The power consumption of discrete component crystal-oscillator circuits is primarily determined by the feedback-amplifier supply current and by the in-circuit capacitance values used. The power consumption of amplifiers fabricated in CMOS is largely proportional to the operating frequency and can be expressed as a power-dissipation capacitance value.

Ceramic circuits typically specify larger load capacitance values than crystal circuits, and draw still more current than the crystal circuit using the same amplifier.

#### Advantage of Quartz Crystal

Good Frequency Accuracy and Good Stability Over Temperature.

#### Advantage of Ceramics

##### Cost Saving

Lower cost than crystal resonators.

##### Smaller Package Size

Miniaturized packaging technology results in very small mainstream packages. Built-in load capacitors are included in same miniature package.

##### Quicker Rise Up of Oscillation

Rise time is generally approx.  $1/10^2$  of a crystal resonator, significantly faster startup possible.

##### Drive Level Free Circuit Design

Due to better holding method of the ceramic element, drive level is not a concern for piezoelectric type resonators.

##### Variety of Characteristics

It is possible to control the material (type and amount) used to make the ceramic material, allowing for various characteristics to be achieved.

##### Overtone Oscillation with No Tank

Materials used to make a ceramic material that naturally suppresses its own fundamental response and allows the third overtone response to be used as the oscillation frequency, without addition external tank circuit.

### Replace the Crystal?

Piezoelectric resonators provide an attractive alternative to quartz crystals for oscillation frequency stabilization in many applications. Their low cost, mechanical ruggedness and small size often outweigh the reduced precision to which frequencies can be controlled, when compared to quartz devices. Token resonators are now available in surface mountable packages suitable for automated production processes.

Reducing cost is a key issue for any existing or new design. A popular avenue for cost reduction is replacing a crystal resonator with a ceramics, when possible.

The most important factor for this replacement is frequency tolerance. If your design can accept the looser frequency tolerance of a piezoelectric resonator, then you can gain the benefits offered by a modern ceramic resonator.

Besides cost reduction, ceramics offer impressive size reductions and included two built-in load capacitors. This allows for smaller PCB area to be used and less time in part placement (one part verse three with a crystal).



# Quartz Crystal Resonators (TACA)

## ► Product Introduction

### A New Package Type - Surface Mount Ceramic Housed Quartz Crystal Resonator.

#### Features :

- Seam welded ceramic package, 1.2mm max. low profile.
- Ideally suit for disc driver, PCMCIA, PC and hand-held products.
- Tight stability, High reliability, Wide frequency range, High frequency.
- Rugged AT-cut crystal construction, Ultra miniature for maximum spacing saving.
- Tape and Reel packing method, Tight specifications available, RoHS Compliant.

Token Electronics offers two series SMD Quartz Crystals in terms of TA\*C series and TA\*CA series. The TA\*C series incorporates a sub-miniature AT-cut strip quartz crystal resonator packed in a miniature 4.0×2.5×1.2mm ceramic package, while the TA\*CA series incorporates a sub-miniature AT-cut strip quartz crystal unit housed in a miniature 2-pad 4.0×2.5mm ceramic package.

Both compact crystals chip components of TA\*C series and TA\*CA series are ideal for surface mount, densely-populated PCB applications.

Contact us with your specific needs. For more information, please link to Token official website "[Ceramic Resonators](#)".



## ► Dimensions

### Configurations & Dimensions (TA7C/6C/5C/4C)

Part Number	Dimensions (unit: mm)								
	L1	L2	L3	L4	L5	L6	L7	L8	L9
TA4C TA4CA	4.0±0.3	2.5±0.3	1.2±0.2	1.2±0.2	0.9±0.2	4.2±0.2	2.7±0.2	1.4±0.2	1.1±0.2
TA5C TA5CA	5.0±0.3	3.2±0.3	1.2±0.2	1.4±0.2	1.0±0.2	5.2±0.2	3.4±0.2	1.6±0.2	1.2±0.2
TA6C TA6CA	6.0±0.3	3.5±0.3	1.2±0.2	1.5±0.2	1.2±0.2	6.2±0.2	3.7±0.2	1.8±0.2	1.4±0.2
TA7C TA7CA	7.0±0.3	5.0±0.3	1.2±0.2	1.5±0.2	1.2±0.2	8.0±0.2	3.9±0.2	2.2±0.2	1.4±0.2

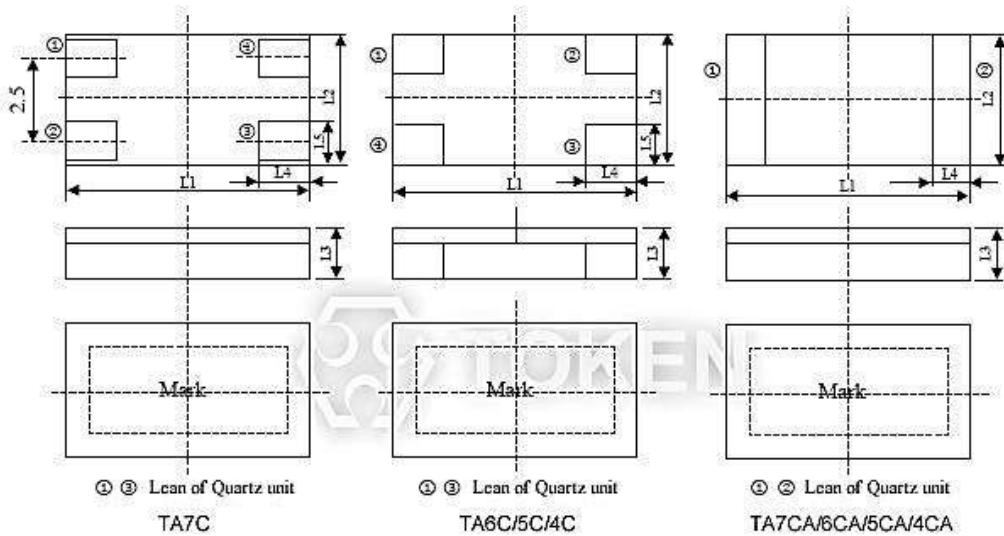

(TA7C/6C/5C/4C) Configurations & Dimensions



## Electrical Spec.

### Electrical Specifications (TA7C/6C/5C/4C)

Part Number	Frequency Range (MHz)	Resonance Resistance ( $\Omega$ ) Max	Fundamental / Overtone	Adjustment Tolerance $\times 10^{-6}$	Temp.Range Tolerance Over $\times 10^{-6}$
TA4C TA4CA	12.000 ~ 19.999	80	Fundamental	30	50
	20.000 ~ 25.999	70			
	26.000 ~ 36.000	50			
TA5C TA5CA	10.000 ~ 11.999	120			
	12.000 ~ 14.399	80			
	14.400 ~ 36.000	50			
TA6C TA6CA	8.000 ~ 11.999	80			
	12.000 ~ 16.000	60			
	16.001 ~ 40.000	40			
TA7C TA7CA	7.600 ~ 11.999	80			
	12.000 ~ 16.000	60			
	16.001 ~ 35.000	40			

## Peeling Strength

### Test Condition Of Peeling Strength (TA7C/6C/5C/4C)

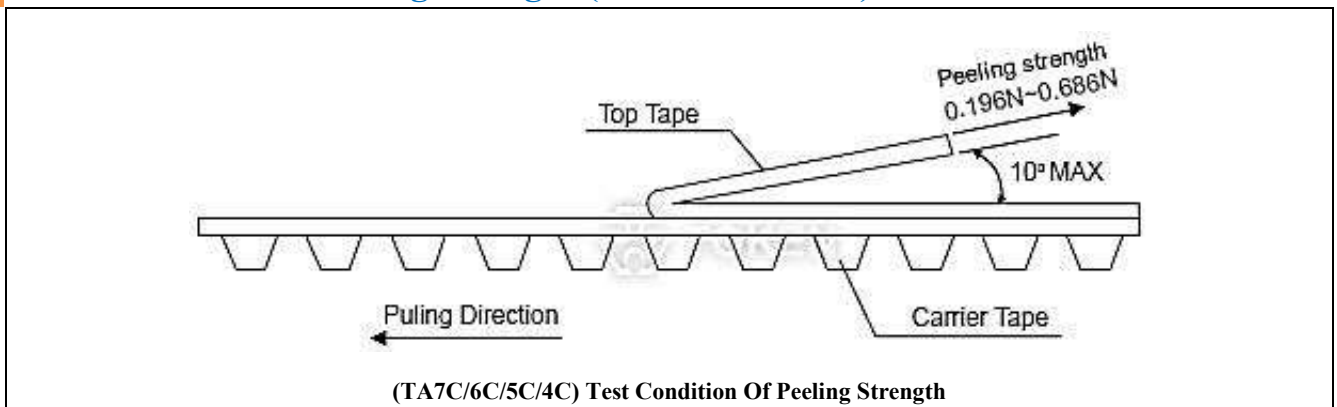

## Land Pattern

### Recommended Land Pattern (TA7C/6C/5C/4C)

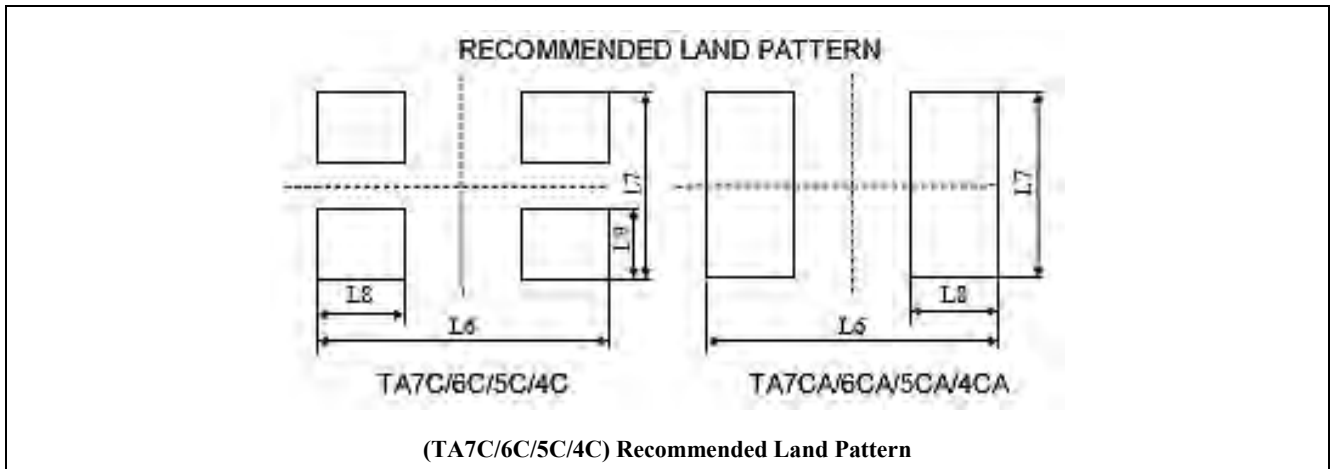

## Reflow Soldering

### Recommended Reflow Soldering Standard Conditions (TA7C/6C/5C/4C)

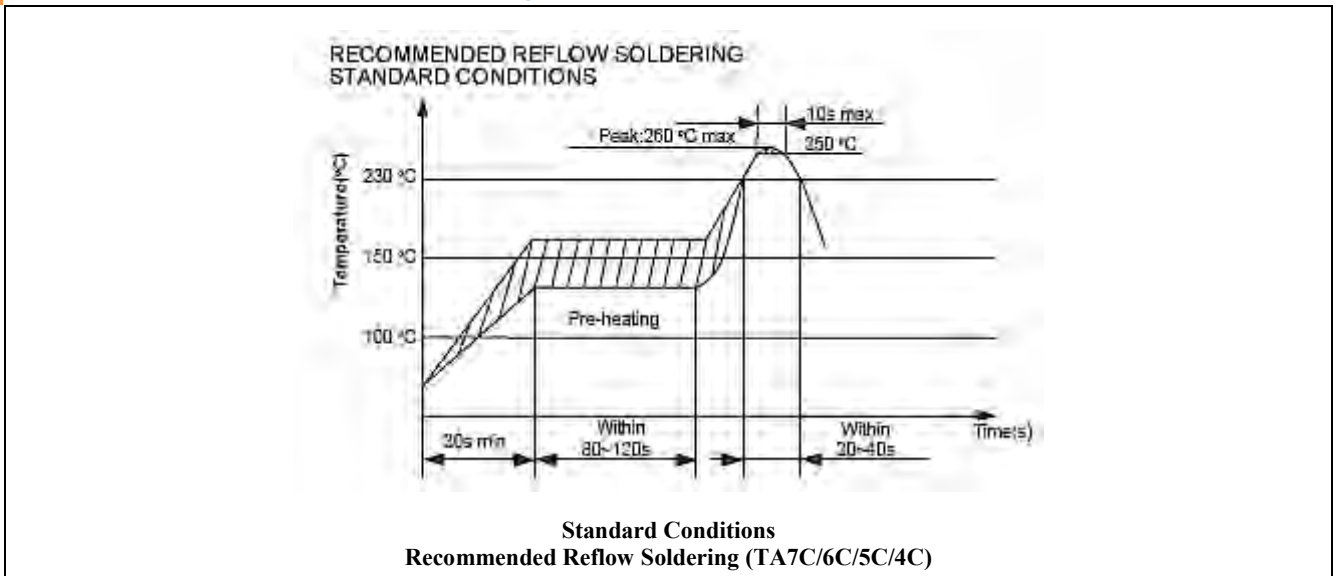

## ► Packing & Reel

### Packing Method (TA7C/6C/5C/4C)

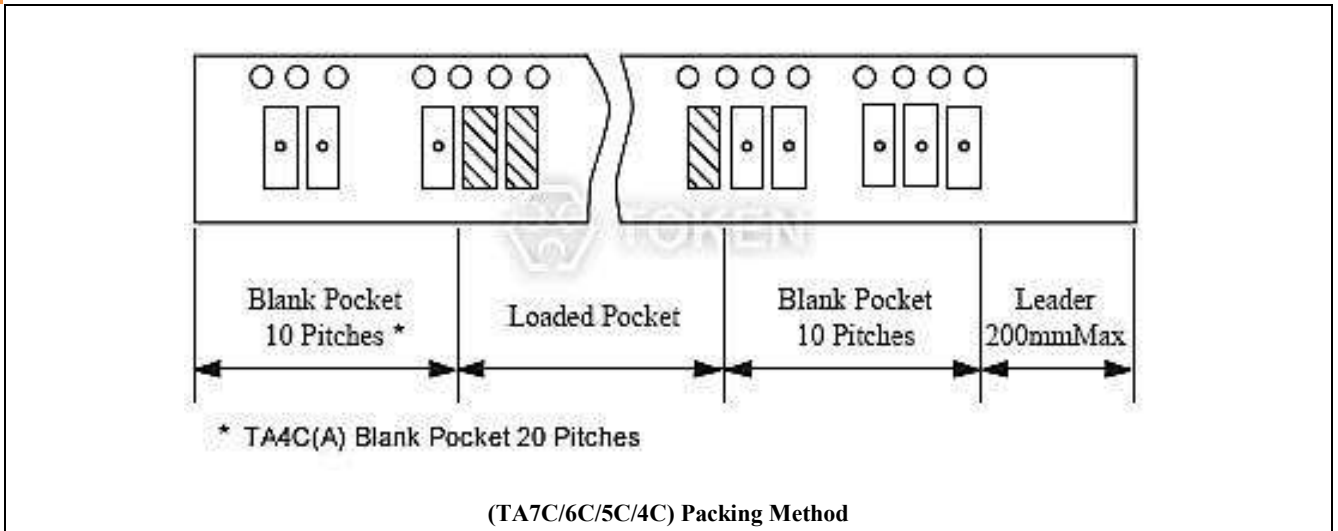

### Reel Dimensions (Unit: mm) (TA7C/6C/5C/4C)

ΦA	ΦB	W	T	Pieces per reel	Carrier tape size
179 ± 2	60typ	12.4min	19.4max	3000typ	12
179 ± 2	60typ	16.4min	22.4max	1000typ	16
330 ± 3	80min	12.4min	19.4max	4000typ	12
330 ± 3	80min	16.4min	22.4max	4000typ	16
179 ± 2	60typ	8.4min	12.4max	3000typ	8

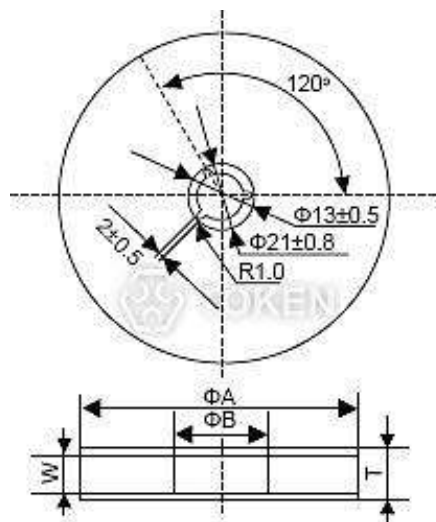

(TA7C/6C/5C/4C) Reel Dimensions

● \* typ : (Typical Value)



## Carrier Tape

### Carrier Tape Dimensions (TA7C/6C/5C/4C)

Part Number	Dimensions (unit: mm)													
	A	B	C	D	E	F	G	H	ΦJ	ΦN	Mmax	Rmax	K	T
TA4C TA4CA	2.9±0.2	4.4±0.2	12.0±0.2	5.5±0.1	1.75±0.1	4.0±0.1	4.0±0.1	2.0±0.1	1.5±0.1	1.6±0.1	10°	0.3	1.4±0.2	0.3±0.1
TA5C TA5CA	3.6±0.2	5.4±0.2	16.0±0.2	7.5±0.1	1.75±0.1	4.0±0.1	2.0±0.1	1.5±0.1	1.6±0.1	1.6±0.1	10°	0.3	1.4±0.2	0.3±0.1
TA6C TA6CA	3.9±0.2	6.4±0.2	16.0±0.2	7.5±0.1	1.75±0.1	4.0±0.1	2.0±0.1	1.5±0.1	1.6±0.1	1.6±0.1	10°	0.3	1.4±0.2	0.3±0.1
TA7C TA7CA	5.4±0.2	7.4±0.2	16.0±0.2	7.5±0.1	1.75±0.1	4.0±0.1	2.0±0.1	1.5±0.1	1.6±0.1	1.6±0.1	10°	0.3	1.4±0.2	0.3±0.1

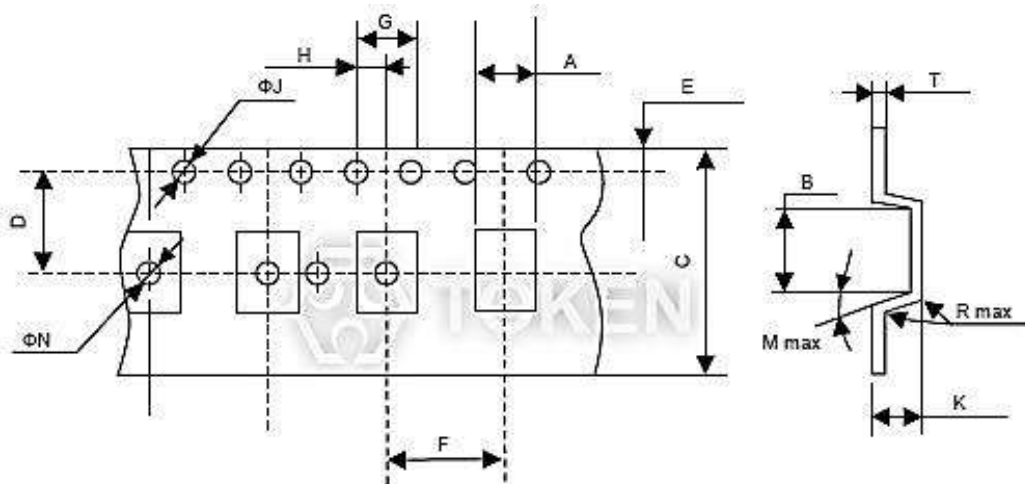

(TA7C/6C/5C/4C) Carrier Tape Dimensions

## Order Codes

### Order Codes (TA7C/6C/5C/4C)

TA6C	12.000M	TR
Part Number	Frequency (MHz)	Package
		P Bulk
		TR Taping Reel

### ▶ General Information

#### Token Cuts Resonator Size and Cost

Token's Resonators are made of high stability piezoelectric ceramics that function as a mechanical resonator. This device has been developed to function as a reference signal generator. The frequency is primarily adjusted by the size and thickness of the ceramic element. With the advance of the IC technology, various equipment may be controlled by a single LSI (Large-Scale Integration) integrated circuit, such as the one-chip microprocessor.

Resonator can be used as the timing element in most microprocessor based equipment. In the future, more and more applications will use **ceramic resonator** because of its high stability non-adjustment performance, miniature size and cost savings.

Typical applications include TVs, VCRs, remote controls and toys, voice synthesizers, automotive electronic devices, copiers, telephones, cameras, communication equipment.

Token offers a full range of industry standard through hole and surface mount resonators both with and without internal capacitors. For standard Operating Temperatures ( $-20^{\circ}\text{C}$  to  $80^{\circ}\text{C}$ ), and for Automotive applications ( $-40^{\circ}\text{C}$  to  $+125^{\circ}\text{C}$ ), with a wide range of frequencies and frequency stability options. Additionally, Token Application Engineering and Design capabilities allow for custom design and characterization requirements that meet the demands of most applications.



# Ceramic Resonators (ZTA)

## ▶ Product Introduction

### Introduction (ZTA)

#### Benefit Features :

- All (ZTA) are epoxy coated and completely washable.
- Resistant to damage from impact and vibration.
- Tape and reel package are both available.
- Excellent temperature stability ( $\pm 0.3\%$ ).
- Low cost.

Token (ZTA) washable epoxy coated ceramic resonator is compatible to Murata resonator CSA. Token resonators MHz (ZTA) series cover the frequency range of 1.79 MHz to 60.00 MHz with an initial frequency tolerance  $\pm 0.5\%$ , stability  $\pm 0.3\%$  at operating temperature  $-20^{\circ}\text{C} \sim +80^{\circ}\text{C}$ , and aging tolerance  $\pm 0.3\%$ . The tight tolerance frees the design engineers from having to use Quartz Crystals higher cost components and still achieve desired performance and reliability targets.



Tolerance is the main key characteristics to evaluate for a resonator. The total tolerance is the addition of the initial tolerance, temperature tolerance and aging tolerance. Tighter tolerances are possible through design advancements, material refinement and manufacturing techniques. Token's design and material improve the temperature and aging characteristics of the resonator. Token's manufacturing ability sort to tighter initial tolerances.

Token (ZTA) resonators implement the mechanical resonance of piezoelectric ceramics that result in different vibration behaviors (modes) depending on the resonance frequency. Token (ZTA) series design utilizes this ceramic substrate by applying two metal electrodes evenly placed on both sides of the substrate. When voltage is applied, vibration of the ceramic substrate occurs between the electrodes. The thickness of the ceramic substrate determines the resonant frequency of the resonator.

The (ZTA) series conform to the RoHS directive. Custom parts are available on request. Token will also produce devices outside these specifications to meet specific customer requirements, contact us with your specific needs. For more information, please link to Token official website "[Ceramic Resonators](http://www.token.com.tw)".

## Dimensions

### Dimensions (ZTA)

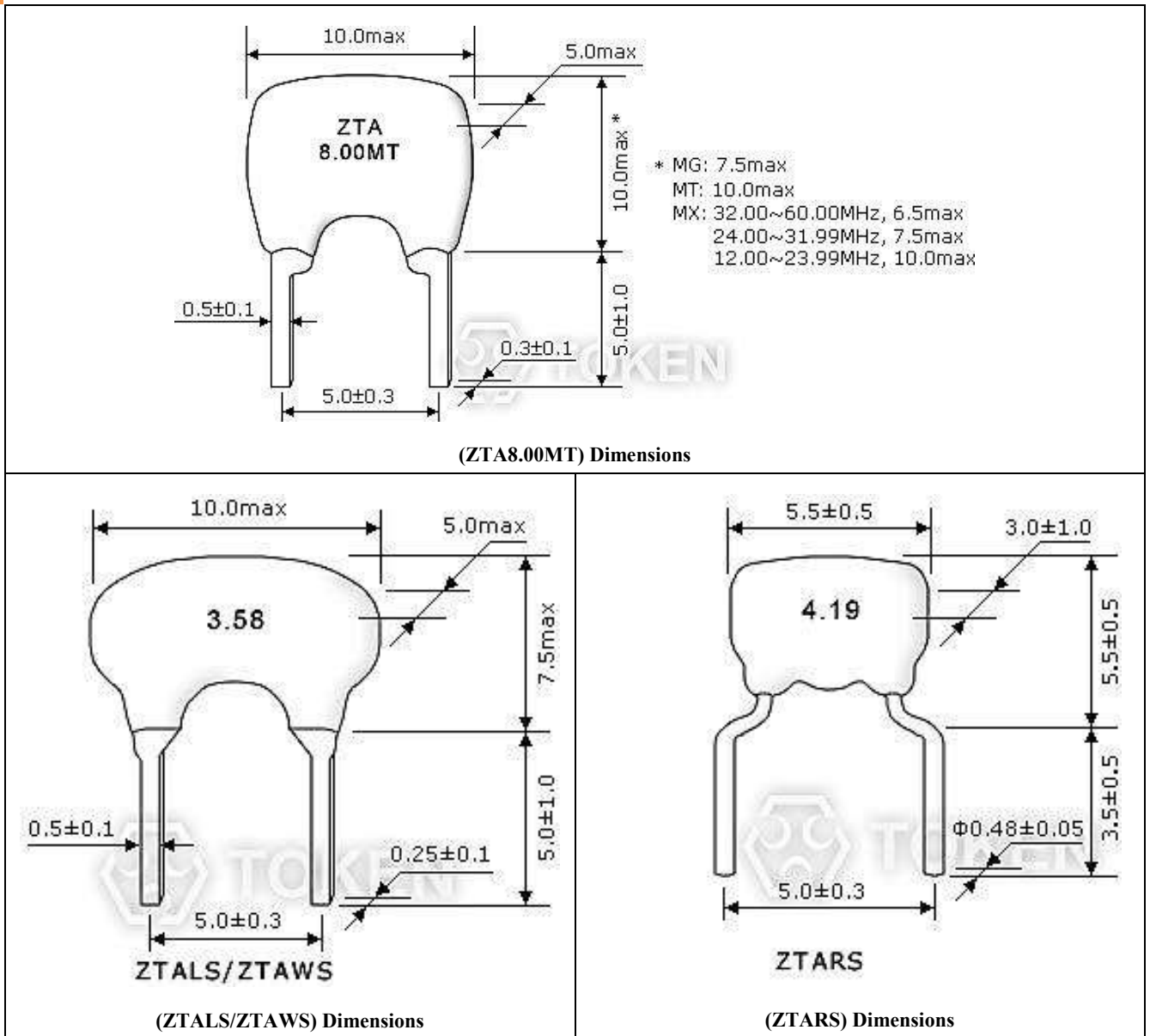

## ► Technical Characteristics

### Technical Characteristics (ZTA)

Part Number	Frequency Range (MHz)	Frequency Accuracy (at 25°C) (%)	Stability in Temperature (-20°C ~ +80°C) (%)	Operating Temperature (°C)	Aging For Ten Years (%)
ZTA***MG	1.79 ~ 6.00	± 0.5	± 0.3	-20 ~ +80	± 0.3
ZTAWS***MG	1.79 ~ 6.00	± 0.5	± 0.3	-20 ~ +80	± 0.3
ZTALS***MG	3.00 ~ 8.00	± 0.5	± 0.3	-20 ~ +80	± 0.3
ZTARS***MG	3.00 ~ 10.00	± 0.5	± 0.3	-20 ~ +80	± 0.3
ZTA***MT	6.00 ~ 13.00	± 0.5	± 0.3	-20 ~ +80	± 0.3
ZTA***MX	12.00 ~ 60.00	± 0.5	± 0.3	-20 ~ +80	± 0.3





## ► Oscillation Circuit for MOS IC

### Understanding Oscillation Circuit for MOS IC (ZTA)

#### Loading Capacitor ( $C_1$ & $C_2$ )

The stability of the oscillation circuit is mainly determined by the  $C_1$  &  $C_2$  values. If the load capacitance is too small, unstable oscillation will occur because of oscillation waveform distortion. If too high, a stop in oscillation can be expected. When comparing the same IC, oscillation circuits with lower frequencies require higher capacitance.

#### Feedback Resistor ( $R = 1M\Omega$ ):

A Feedback Resistor is used to determine the oscillation circuit bias. The feedback resistance will contribute to instability if it is too large by reducing feedback. Conversely, if it is too small, increases in current will be realized thereby reducing gain. Recent developments in IC design allows for the integration of the feedback resistor in many cases.

#### Bias resistor ( $R_b$ optional):

A Bias Resistor can be utilized in the Resonator Oscillation Circuit to change the bias point when a reduction in IC gain is required, or to suppress unstable oscillation. This may be especially considered when a 3 stage buffered IC, or TTL IC, is used. Token Engineers can help with the circuit design if needed.

#### Damping Resistor ( $R_d$ optional):

Abnormal harmonic oscillation can be suppressed using a dampening resistor. The dampening resistor and load capacitors work together as a low-pass filter to reduce gain in the MHz range of oscillation.

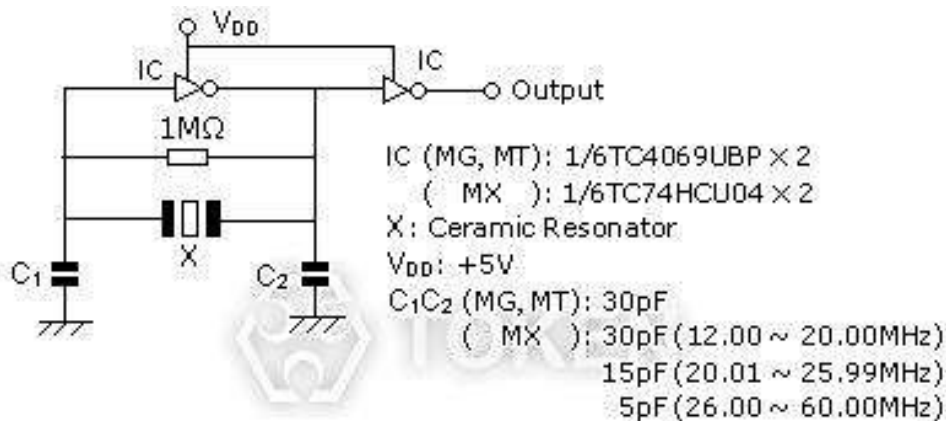

MHz Resonator (ZTA) Test Circuit for MOS IC

### ZTA Resonator Optimum IC Evaluations

Tolerance is determined by the design of the resonator. However stability and correlation is determined by the IC evaluation. The microcontroller is evaluated with the ceramic resonators to determine the best possible circuit conditions to achieve stability and stable oscillation.

In addition, frequency correlation is measured to meet the tight initial frequency tolerance required. For the tight tolerance resonators the IC evaluation must be completed on the final circuit board layout. The final circuit boards provide the most accurate measurement of the frequency correlation.

This measurement will account for the effects of stray capacitance on the oscillation frequency. Once the correlation is determined the frequency of the resonator is adjusted to compensate for the correlation.

## Order Codes

### Order Codes (ZTA)

ZTA8.00MT	P	
Part Number	Package	
	P	Bulk
	TR	Taping Reel

## General Information

### Token Cuts Resonator Size and Cost

Token's Resonators are made of high stability piezoelectric ceramics that function as a mechanical resonator. This device has been developed to function as a reference signal generator. The frequency is primarily adjusted by the size and thickness of the ceramic element. With the advance of the IC technology, various equipment may be controlled by a single LSI (Large-Scale Integration) integrated circuit, such as the one-chip microprocessor.

Resonator can be used as the timing element in most microprocessor based equipment. In the future, more and more applications will use **ceramic resonator** because of its high stability non-adjustment performance, miniature size and cost savings.

Typical applications include TVs, VCRs, remote controls and toys, voice synthesizers, automotive electronic devices, copiers, telephones, cameras, communication equipment.

Token offers a full range of industry standard through hole and surface mount resonators both with and without internal capacitors. For standard Operating Temperatures (-20°C to 80°C), and for Automotive applications (-40°C to +125°C), with a wide range of frequencies and frequency stability options. Additionally, Token Application Engineering and Design capabilities allow for custom design and characterization requirements that meet the demands of most applications.



# Ceramic Resonators (ZTB)

## ► Product Introduction

**Token KHz Ceramic Resonators (ZTB) is Murata resonator CSB compatible.**

### Features :

- Oscillating circuits requiring no adjustment can be designed by utilizing these resonators in conjunction with transistors or appropriate ICs.
- The ZTB series is stable over a wide temperature range and with respect to long-term aging.
- Miniature and lightweight, standardized for use in low profile devices.
- Highly reliable design with excellent environmental resistance.
- The ZTB series comprises fixed, tuned, solid-state devices.
- Operation Temperature (-20°C ~ +80°C).

### Applications :

- Square-wave and sine-wave oscillators.
- Clock generator for microprocessors.
- Remote control systems.

Token KHz Ceramic Resonators (ZTB) is Murata resonator CSB compatible. The (ZTB) series ceramic resonators owe their development to Token's expert technologies and the application of mass production techniques typically utilized in the manufacture of piezoelectric ceramic components. Because of their consistent high quality and high mechanical Q, the (ZTB) series are ideally suited to remote control unit and microprocessor applications.

Token Resonators KHz (ZTB) series is designed to provide the engineer with a rugged, relatively low frequency device in the frequency range of 190 kHz to 1,250 kHz. Initial frequency tolerance is  $\pm 0.5\%$  which compares very favorably to the nominal  $\pm 2\% \sim \pm 3\%$  requirements of one chip microprocessors. Stability and Aging Tolerance are tight to  $\pm 0.3\%$ .

The (ZTB) series conform to the RoHS directive. Token will also produce devices outside these specifications to meet customer requirements, with comprehensive application engineering and design support available for customers worldwide. Contact us with your specific needs. For more information, please link to Token official website "[Ceramic Resonators](http://www.token.com.tw)".



## ► Dimensions

### Dimensions (Unit: mm; Tolerance: $\pm 0.3\text{mm}$ ) (ZTB)

Frequency Range (kHz)	W width	T thickness	H height	S lead space	L lead length
190~249	13.5	3.6	14.7	10.0	8.0
250~374	11.0	3.6	12.2	7.7	7.0
375~429	7.9	3.6	9.3	5.0	6.0
430~699	7.0	3.5	9.0	5.0	4.0(6.0)
700~1250	5.1	2.2	6.3	2.5	4.0

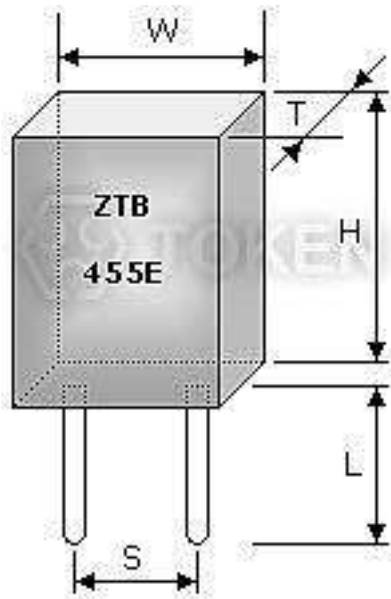

KHz (ZTB) Series Dimensions

## ► Technical Characteristics

### Technical Characteristics (ZTB)

Part Number	Frequency Accuracy (at 25°C)	Resonant Impedance ( $\Omega$ )	Stability in Temperature (-20°C~+80°C)(%)	Aging For 10 Years (%)	Load Capacitance (pF)	
					C1	C2
ZTB82 ~ ZTB189 *	$\pm 2\text{kHz}$	$\leq 20$	$\pm 0.3$	$\pm 0.3$	/	/
ZTB190D ~ ZTB249D	$\pm 1\text{kHz}$	$\leq 20$	$\pm 0.3$	$\pm 0.3$	330	470
ZTB250D ~ ZTB374D	$\pm 1\text{kHz}$	$\leq 20$	$\pm 0.3$	$\pm 0.3$	220	470
ZTB375P ~ ZTB429P	$\pm 2\text{kHz}$	$\leq 20$	$\pm 0.3$	$\pm 0.3$	120	470
ZTB430E ~ ZTB509E	$\pm 2\text{kHz}$	$\leq 20$	$\pm 0.3$	$\pm 0.3$	100	100
ZTB510P ~ ZTB699P	$\pm 2\text{kHz}$	$\leq 30$	$\pm 0.3$	$\pm 0.3$	100	100
ZTB700J ~ ZTB999J	$\pm 0.5\%$	$\leq 70$	$\pm 0.3$	$\pm 0.3$	100	100
ZTB1000J ~ ZTB1250J	$\pm 0.5\%$	$\leq 100$	$\pm 0.3$	$\pm 0.3$	100	100

● \* Note: ZTB82 ~ ZTB189 series is new products of custom design.



## ▶ Test Circuit for MOS IC

### Resonator Selection - Test Circuit for MOS IC (ZTB)

#### Loading Capacitor ( $C_1$ & $C_2$ ):

The stability of the oscillation circuit is mainly determined by the  $C_1$  &  $C_2$  values. If the load capacitance is too small, unstable oscillation will occur because of oscillation waveform distortion. If too high, a stop in oscillation can be expected. When comparing the same IC, oscillation circuits with lower frequencies require higher capacitance. Token Engineers can help with the circuit design if needed.

#### Feedback Resistor ( $R = 1M\Omega$ ):

A Feedback Resistor is used to determine the oscillation circuit bias. The feedback resistance will contribute to instability if it is too large by reducing feedback. Conversely, if it is too small, increases in current will be realized thereby reducing gain. Recent developments in IC design allows for the integration of the feedback resistor in many cases.

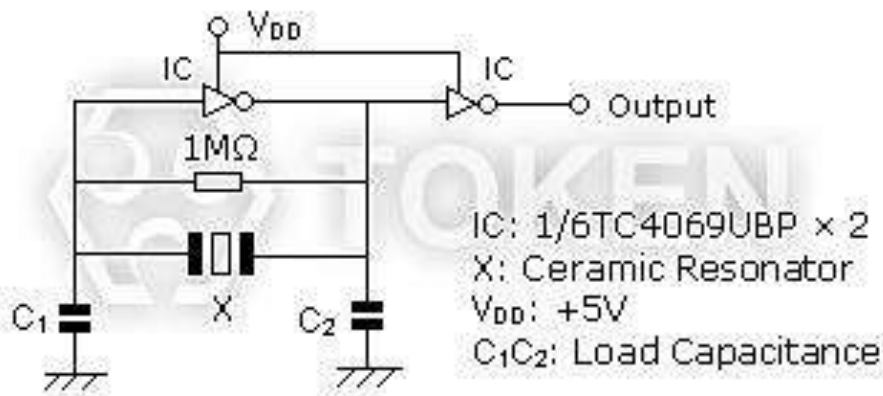

KHz (ZTB) Test Circuit for MOS IC

### Resonator Optimum - IC Evaluations (ZTB)

Due to the properties of resonators, IC matching must be studied and performed to satisfy oscillation conditions.

Tolerance is determined by the design of the resonator. However stability and correlation is determined by the IC evaluation. The microcontroller is evaluated with the resonators to determine the best possible circuit conditions to achieve stability and stable oscillation.

In addition, frequency correlation is measured to meet the tight initial frequency tolerance required. For the tight tolerance resonators the IC evaluation must be completed on the final circuit board layout. The final circuit boards provide the most accurate measurement of the frequency correlation.

This measurement will account for the effects of stray capacitance on the oscillation frequency. Once the correlation is determined the frequency of the resonator is adjusted to compensate for the correlation.

## ▶ Order Codes

### Order Codes (ZTB)

ZTB455E	P	
Part Number	Package	
	P	Bulk
	TR	Taping Reel

## ▶ General Information

### Token Cuts Resonator Size and Cost

Token's Resonators are made of high stability piezoelectric ceramics that function as a mechanical resonator. This device has been developed to function as a reference signal generator. The frequency is primarily adjusted by the size and thickness of the ceramic element. With the advance of the IC technology, various equipment may be controlled by a single LSI (Large-Scale Integration) integrated circuit, such as the one-chip microprocessor.

Resonator can be used as the timing element in most microprocessor based equipment. In the future, more and more applications will use **ceramic resonator** because of its high stability non-adjustment performance, miniature size and cost savings.

Typical applications include TVs, VCRs, remote controls and toys, voice synthesizers, automotive electronic devices, copiers, telephones, cameras, communication equipment.

Token offers a full range of industry standard through hole and surface mount resonators both with and without internal capacitors. For standard Operating Temperatures (-20°C to 80°C), and for Automotive applications (-40°C to +125°C), with a wide range of frequencies and frequency stability options. Additionally, Token Application Engineering and Design capabilities allow for custom design and characterization requirements that meet the demands of most applications.



# Ceramic Resonators

## (ZTB456/500/503/912F)

### ▶ Product Introduction

#### Introduction (ZTB456/500/503/912F)

##### Benefit Features :

- Highly reliable design with excellent environmental resistance.
- Standardized for use in low profile devices.
- Low cost.

Optimum Ceramic Resonator Selection of ZTB456/500/503/912F Oscillation. Optimum Resonator selection of Token ZTB456/500/503/912F oscillation parameters make possible according to applications. The ZTB456/500/503/912F series provide reliable start up and stable oscillation in microprocessor circuits across a wide variety of applications.

The ZTB 456F multiplexer's series is designed to provide frequency modulation for HI-FI stereo application. These resonators are offered in the frequency accuracy  $19 \text{ kHz} \pm 38\text{Hz}$  and  $456 \text{ kHz} \pm 2 \text{ kHz}$  with various applicable IC. The ZTB912F Multiplexers Series is specially designed to provide frequency modulation for HI-FI automobile stereo application. The ZTB 500/503F Series is designed for TV horizontal synthesizer circuits. These resonators are offered in the following frequency accuracy with applicable IC. All ZTB456/500/503/912F are Murata Compatible CSB456/503/912F.

Application of ceramic resonators specific designs also available including tighter tolerance specifications adjusted to frequency requirements. Products conform to the RoHS directive.

Token will also produce devices outside these specifications to meet customer requirements, with comprehensive application engineering and design support available for customers worldwide.

Contact us with your specific needs. For more information, please link to Token official website "[Ceramic Resonators](#)".





## ► Dimensions

**Dimensions (Unit: mm; Tolerance:  $\pm 0.3$ mm) KHz (ZTB456/500/503/912F)**

Type	ZTB 456 / 500 / 503F	ZTB 912F
W (width)	7.0	5.0
T (thickness)	3.5	2.2
H (height)	9.0	6.0
S (lead space)	5.0	2.5
L (lead length)	4.0	4.0

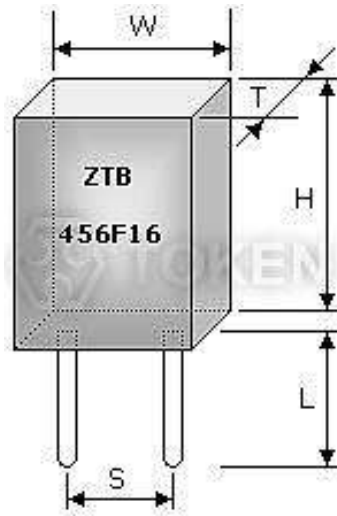

**KHz (ZTB\*\*\*F) Dimensions**

## ▶ Technical Characteristics

### Technical Characteristics KHz (ZTB456/500/503/912F)

Part Number	Frequency Accuracy	Applicable IC	
ZTB456F11	19.000 kHz ± 38 Hz	LA3430	SANYO
ZTB456F15	19.000 kHz ± 38 Hz	LA1832	SANYO
ZTB456F16	19.000 kHz ± 38 Hz	TA8122AN	TOSHIBA
ZTB456F18	19.000 kHz ± 38 Hz	TA8132N	TOSHIBA
ZTB456F33	456 kHz ± 2 Hz	LA2232	SANYO
ZTB480E14	480+0.2%, -0.4%	TC31018P	TOSHIBA
ZTB500F2	500.0 kHz ± 2 kHz	μPC1401C	NEC
ZTB500F9	500.0 kHz ± 2 kHz	M51308SP	MITSUBISHI
ZTB500F25	15.680 kHz ± 0.4%	LA7680	SANYO
ZTB500F40	15.680 kHz ± 0.4%	TA8691N	TOSHIBA
ZTB503F2	503.5 kHz ± 2 kHz	μPC1401C	NEC
ZTB503F5	504.5 kHz ± 2 kHz	LA7620	SANYO
ZTB503F10	15.734 kHz ± 0.5%	TA7777P	TOSHIBA
ZTB503F12	503.5 kHz ± 2 kHz	LDA3586N	THOMSON
ZTB503F15	505.1 kHz ± 2 kHz	LA7650	SANYO
ZTB503F30	503.5 kHz ± 1.5 kHz	TA8654AN	TOSHIBA
ZTB503F38	15.734 kHz ± 62 kHz	AN5302	MATSUSHITA
ZTB912F	923.0 kHz ± 0.3%	LA1780	SANYO
ZTB912F101	918.5 kHz ± 0.3%	AN7291	MATSUSHITA
ZTB912F104	925.0 kHz ± 0.3%	LA1867NM	SANYO

## Order Codes

### Order Codes KHz (ZTB456/500/503/912F)

ZTB456F16	P
Part Number	Package
P	Bulk
TR	Taping Reel

## General Information

### Token Cuts Resonator Size and Cost

Token's Resonators are made of high stability piezoelectric ceramics that function as a mechanical resonator. This device has been developed to function as a reference signal generator. The frequency is primarily adjusted by the size and thickness of the ceramic element. With the advance of the IC technology, various equipment may be controlled by a single LSI (Large-Scale Integration) integrated circuit, such as the one-chip microprocessor.

Resonator can be used as the timing element in most microprocessor based equipment. In the future, more and more applications will use **ceramic resonator** because of its high stability non-adjustment performance, miniature size and cost savings.

Typical applications include TVs, VCRs, remote controls and toys, voice synthesizers, automotive electronic devices, copiers, telephones, cameras, communication equipment.

Token offers a full range of industry standard through hole and surface mount resonators both with and without internal capacitors. For standard Operating Temperatures (-20°C to 80°C), and for Automotive applications (-40°C to +125°C), with a wide range of frequencies and frequency stability options. Additionally, Token Application Engineering and Design capabilities allow for custom design and characterization requirements that meet the demands of most applications.



# Surface Mountable Resonators (ZTBY)

## ▶ Product Introduction

### Introduction (ZTBY)

Token formed leads surface mountable resonator is compatible to Murata resonator CSBF. Token manufactures a broad range of high quality Ceramic Resonators covering both the KHz and Mhz frequency ranges and a full range of industry standard Through Hole and Surface Mount resonators both with and without internal capacitors. The high quality and extensive coverage of this product line allows optimum design of almost any oscillating circuit.



The surface mountable Ceramic resonators (ZTBY) are one of (ZTB) device series with the frequency range of 375 kHz to 1,250 kHz. Initial frequency tolerance is  $\pm 0.5\%$  which compares very favorably to the nominal  $\pm 2\% \sim \pm 3\%$  requirements of one chip microprocessors. Stability and Aging Tolerance narrows to  $\pm 0.3\%$ . The (ZTBY) Resonator provides reliable start up and stable oscillation in microprocessor circuits across a wide variety of applications.

The (ZTBY) Ceramic resonators stand between quartz crystal oscillators and LC/RC oscillators in regard to accuracy but are considerably smaller, require no adjustments, have improved start-up times, and are low in cost. The (ZTBY) oscillation is dependent upon mechanical resonance associated with their piezoelectric crystalline structure and utilizes the area vibration mode of the piezoelectric element.

Token (ZTBY) resonators conform to the RoHS directive. Application of specific designs also available including different tighter tolerances specification adjusted to frequency requirements.

Contact us with your specific needs. For more information, please link to Token official website "[Ceramic Resonators](http://www.token.com.tw)".



## ▶ Test Circuit for MOS IC

### Resonator Selection - Test Circuit for MOS IC (ZTBY)

#### Loading Capacitor (C1 & C2):

The stability of the oscillation circuit is mainly determined by the C1 & C2 values. If the load capacitance is too small, unstable oscillation will occur because of oscillation waveform distortion. If too high, a stop in oscillation can be expected. When comparing the same IC, oscillation circuits with lower frequencies require higher capacitance.

#### Feedback Resistor (R = 1MΩ):

A Feedback Resistor is used to determine the oscillation circuit bias. The feedback resistance will contribute to instability if it is too large by reducing feedback. Conversely, if it is too small, increases in current will be realized thereby reducing gain. Recent developments in IC design allows for the integration of the feedback resistor in many cases.

Token Engineers can help with the circuit design if needed.

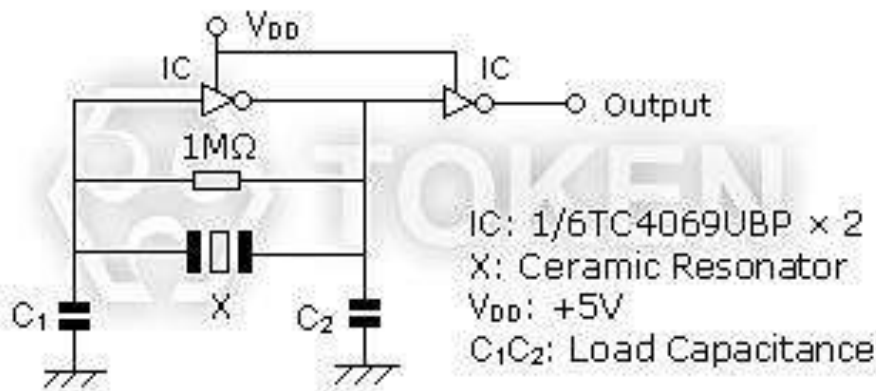

(ZTBY) Test Circuit for MOS IC

### Resonator Optimization - IC Evaluations (ZTBY)

Tolerance is determined by the design of the resonator. However stability and correlation is determined by the IC evaluation. The microcontroller is evaluated with the ceramic resonators to determine the best possible circuit conditions to achieve stability and stable oscillation.

In addition, frequency correlation is measured to meet the tight initial frequency tolerance required. For the tight tolerance resonators the IC evaluation must be completed on the final circuit board layout. The final circuit boards provide the most accurate measurement of the frequency correlation.

This measurement will account for the effects of stray capacitance on the oscillation frequency. Once the correlation is determined the frequency of the resonator is adjusted to compensate for the correlation.

## ▶ Order Codes

### Order Codes (ZTBY)

ZTB	455	Y	P	
Part Number	Center Frequency (KHz)	SMD type	Package	
			P	Bulk
			TR	Taping Reel

## ▶ General Information

### Token Cuts Resonator Size and Cost

Token's Resonators are made of high stability piezoelectric ceramics that function as a mechanical resonator. This device has been developed to function as a reference signal generator. The frequency is primarily adjusted by the size and thickness of the ceramic element. With the advance of the IC technology, various equipment may be controlled by a single LSI (Large-Scale Integration) integrated circuit, such as the one-chip microprocessor.

Resonator can be used as the timing element in most microprocessor based equipment. In the future, more and more applications will use **ceramic resonator** because of its high stability non-adjustment performance, miniature size and cost savings.

Typical applications include TVs, VCRs, remote controls and toys, voice synthesizers, automotive electronic devices, copiers, telephones, cameras, communication equipment.

Token offers a full range of industry standard through hole and surface mount resonators both with and without internal capacitors. For standard Operating Temperatures (-20°C to 80°C), and for Automotive applications (-40°C to +125°C), with a wide range of frequencies and frequency stability options. Additionally, Token Application Engineering and Design capabilities allow for custom design and characterization requirements that meet the demands of most applications.



# Ceramic Resonators (ZTT)

## ► Product Introduction

**Token ceramic resonator with built-in capacitor (ZTT) is compatible to Murata resonator CST series.**

### Benefit Features :

- Built-in load capacitance reduced parts cost and mounting cost.
- Faster start-up time as compared to quartz crystals.
- Excellent temperature stability ( $\pm 0.3\%$ ).
- High density mounting.
- Simplified circuit.
- Low cost.

Token resonators provide an attractive alternative to quartz crystals for oscillation frequency stabilization in many applications. When compared to quartz devices, ceramics' easily mass production, low cost, mechanical ruggedness, and small size often outweigh the reduced precision to which frequencies can be controlled.

Additionally, (ZTT) resonators are better equipped to handle fluctuations in external circuit or power supply voltage due to their use of mechanical resonance and providing stable oscillation without adjustment. Further, these characteristics offer for a much faster rise times and are independent of drive level considerations.

Token resonator (ZTT) series is used as standard clocks for microprocessors in various electronic devices. Token produces miniaturized, high-performance (ZTT) resonator series using its superior fabrication, assembly and packaging technologies. The ZTT device offers frequency range from 1.79 MHz to 60.00 MHz with an initial frequency tolerance of  $\pm 0.5\%$ , stability tolerance  $\pm 0.3\%$  at  $-20^{\circ}\text{C} \sim +80^{\circ}\text{C}$ , and aging tolerance  $\pm 0.3\%$ . The ZTT resonator features built-in capacitance with 3 lead terminals to eliminate any need for external loading capacitors and reduces component count. These devices conform to the RoHS directive.

Application of specific designs also available including tighter tolerances and frequency adjusted to requirements. Contact us with your specific needs. For more information, please link to Token official website "[Ceramic Resonators](http://www.token.com.tw)".





## Dimensions

### Dimensions (Unit: mm) (ZTT)

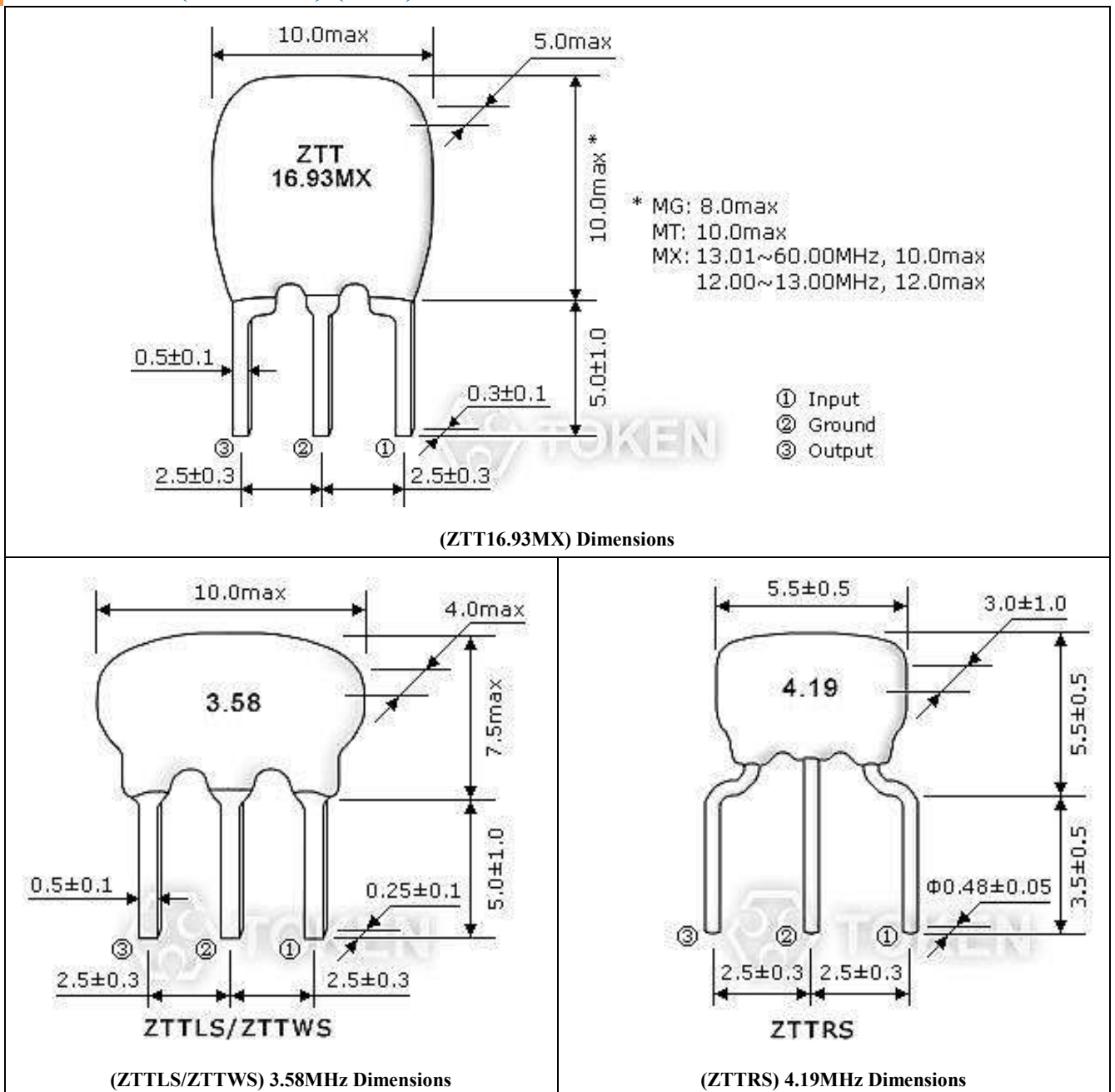

## ► Technical Characteristics

### Technical Characteristics (ZTT)

Part Number	Frequency Range (MHz)	Frequency Accuracy (at 25°C) (%)	Stability in Temperature (-20°C ~ +80°C) (%)	Operating Temperature (°C)	Aging For Ten Years (%)
ZTT***MG	1.79 ~ 6.00	±0.5	±0.3	-20 ~ +80	±0.3
ZTWS***MG	1.79 ~ 6.00	±0.5	±0.3	-20 ~ +80	±0.3
ZTTL***MG	3.00 ~ 8.00	±0.5	±0.3	-20 ~ +80	±0.3
ZTTRS***MG	3.00 ~ 10.00	±0.5	±0.3	-20 ~ +80	±0.3
ZTT***MT	6.00 ~ 13.00	±0.5	±0.3	-20 ~ +80	±0.3
ZTT***MX	12.00 ~ 60.00	±0.5	±0.3	-20 ~ +80	±0.3



## ▶ Test Circuit for MOS IC

### Test Circuit for MOS IC (ZTT)

#### Loading Capacitor ( $C_1$ & $C_2$ )

The stability of the oscillation circuit is mainly determined by the  $C_1$  &  $C_2$  values. If the load capacitance is too small, unstable oscillation will occur because of oscillation waveform distortion. If too high, a stop in oscillation can be expected. When comparing the same IC, oscillation circuits with lower frequencies require higher capacitance.

#### Feedback Resistor ( $R = 1M\Omega$ ):

A Feedback Resistor is used to determine the oscillation circuit bias. The feedback resistance will contribute to instability if it is too large by reducing feedback. Conversely, if it is too small, increases in current will be realized thereby reducing gain. Recent developments in IC design allows for the integration of the feedback resistor in many cases.

#### Damping Resistor ( $R_d$ optional):

Abnormal harmonic oscillation can be suppressed using a dampening resistor. The dampening resistor and load capacitors work together as a low-pass filter to reduce gain in the MHz range of oscillation.

#### Bias resistor ( $R_b$ optional):

A Bias Resistor can be utilized in the Resonator Oscillation Circuit to change the bias point when a reduction in IC gain is required, or to suppress unstable oscillation. This may be especially considered when a 3 stage buffered IC, or TTL IC, is used.

Token Engineers can help with the circuit design if needed.

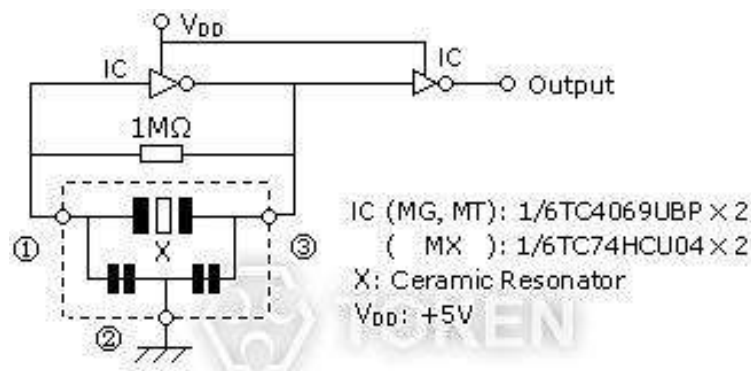

MHz (ZTT) Test Circuit for MOS IC

### Resonator Optimum and IC Evaluations (ZTT)

Tolerance is determined by the design of the resonator. However stability and correlation is determined by the IC evaluation. The microcontroller is evaluated with the ceramic resonators to determine the best possible circuit conditions to achieve stability and stable oscillation.

In addition, frequency correlation is measured to meet the tight initial frequency tolerance required. For the tight tolerance resonators the IC evaluation must be completed on the final circuit board layout. The final circuit boards provide the most accurate measurement of the frequency correlation.

This measurement will account for the effects of stray capacitance on the oscillation frequency. Once the correlation is determined the frequency of the resonator is adjusted to compensate for the correlation.

## ▶ Order Codes

### Order Codes (ZTT)

ZTT16.93MX	P	
Part Number	Package	
	P	Bulk
	TR	Taping Reel

## ▶ General Information

### Token Cuts Resonator Size and Cost

Token's Resonators are made of high stability piezoelectric ceramics that function as a mechanical resonator. This device has been developed to function as a reference signal generator. The frequency is primarily adjusted by the size and thickness of the ceramic element. With the advance of the IC technology, various equipment may be controlled by a single LSI (Large-Scale Integration) integrated circuit, such as the one-chip microprocessor.

Resonator can be used as the timing element in most microprocessor based equipment. In the future, more and more applications will use **ceramic resonator** because of its high stability non-adjustment performance, miniature size and cost savings.

Typical applications include TVs, VCRs, remote controls and toys, voice synthesizers, automotive electronic devices, copiers, telephones, cameras, communication equipment.

Token offers a full range of industry standard through hole and surface mount resonators both with and without internal capacitors. For standard Operating Temperatures (-20°C to 80°C), and for Automotive applications (-40°C to +125°C), with a wide range of frequencies and frequency stability options. Additionally, Token Application Engineering and Design capabilities allow for custom design and characterization requirements that meet the demands of most applications.



# SMD Ceramic Resonators (ZTAC/ZTTC)

## Product Introduction

### Introduction (ZTAC/ZTTC)

#### Features :

- High reliability chip resonator with high temperature withstanding ceramic case.
- Ultra-miniature size is suitable for compact equipment high mounting density.
- Low profile, Reflow solderable, Excellent solderability.

#### Applications :

- Car accessories.
- PDAs, PC peripherals.
- Camcorders, Digital cameras.

Token (ZTAC/ZTTC) series is the smallest surface mount ceramic resonators (Murata resonator CSAC/CSTC compatible). Previously, only higher cost quartz crystal resonators were considered for CAN bus application, due to tighter frequency tolerance requirements than for traditional automotive bus applications. Nowadays, Token utilizes the latest ceramic piezo technology freeing the design engineers from having to use these higher cost components and still achieve desired reliability and performance targets.



Token ZTAC and ZTTC series are the SMD ceramic resonators that meet the frequency tolerance  $\pm 0.5\%$ , temperature tolerance  $\pm 0.3\% \sim \pm 0.4\%$ , and aging tolerance  $\pm 0.3\%$ . The ZTAC and ZTTC covers the frequency range of 1.79 MHz to 50.00 MHz. ZTTC series features a built-in load capacitance. This feature eliminates any need for external loading capacitors and reduces component count, increases reliability and reduces size.

The ZTACE $\times$ MG (3.2  $\times$  1.3 mm) with (max) profile 1.0 mm and ZTACW $\times$ MX (2.5  $\times$  2.0 mm) with (max) profile 1.5 mm are the smallest resonators for their respective frequency ranges. All ZTAC and ZTTC series are surface mount devices (SMD) with operating temperature range is  $-20^{\circ}\text{C}$  to  $+80^{\circ}\text{C}$ .

Tolerance is the main key characteristics to evaluate for a resonator. The total tolerance is the addition of the initial tolerance, temperature tolerance and aging tolerance. Tighter tolerances are possible through design advancements, material refinement and manufacturing techniques. Token's design and material improve the temperature and aging characteristics of the resonator. Token's manufacturing ability sort to tighter initial tolerances.

Custom parts are available on request. Token will also produce devices outside these specifications to meet specific customer requirements, contact us with your specific needs. For more information, please link to Token official website "[Ceramic Resonators](http://www.token.com.tw)".



## ZTAC Dimensions

### Dimensions (ZTAC)

Part Number	Dimensions (Unit: mm)				
	L	W	H	P2	T
ZTACC*MG	7.4±0.2	3.4±0.2	1.8±0.2	1.2±0.2	5.0±0.3
ZTACR*MG	4.5±0.2	2.0±0.2	1.2max	0.8±0.2	3.0±0.2
ZTACE*MG	3.2±0.1	1.3±0.1	1.0max	0.4±0.1	2.4±0.1
ZTACS*MT/MX	4.7±0.2	4.1±0.2	(1.2+A)±0.2	0.8±0.2	3.9±0.2
ZTACV*MT/MX	3.7±0.2	3.1±0.2	(1.0+A)±0.2	0.7±0.2	3.0±0.2
ZTACW*MX	2.5±0.2	2.0±0.2	1.5max	0.4±0.2	2.0±0.2

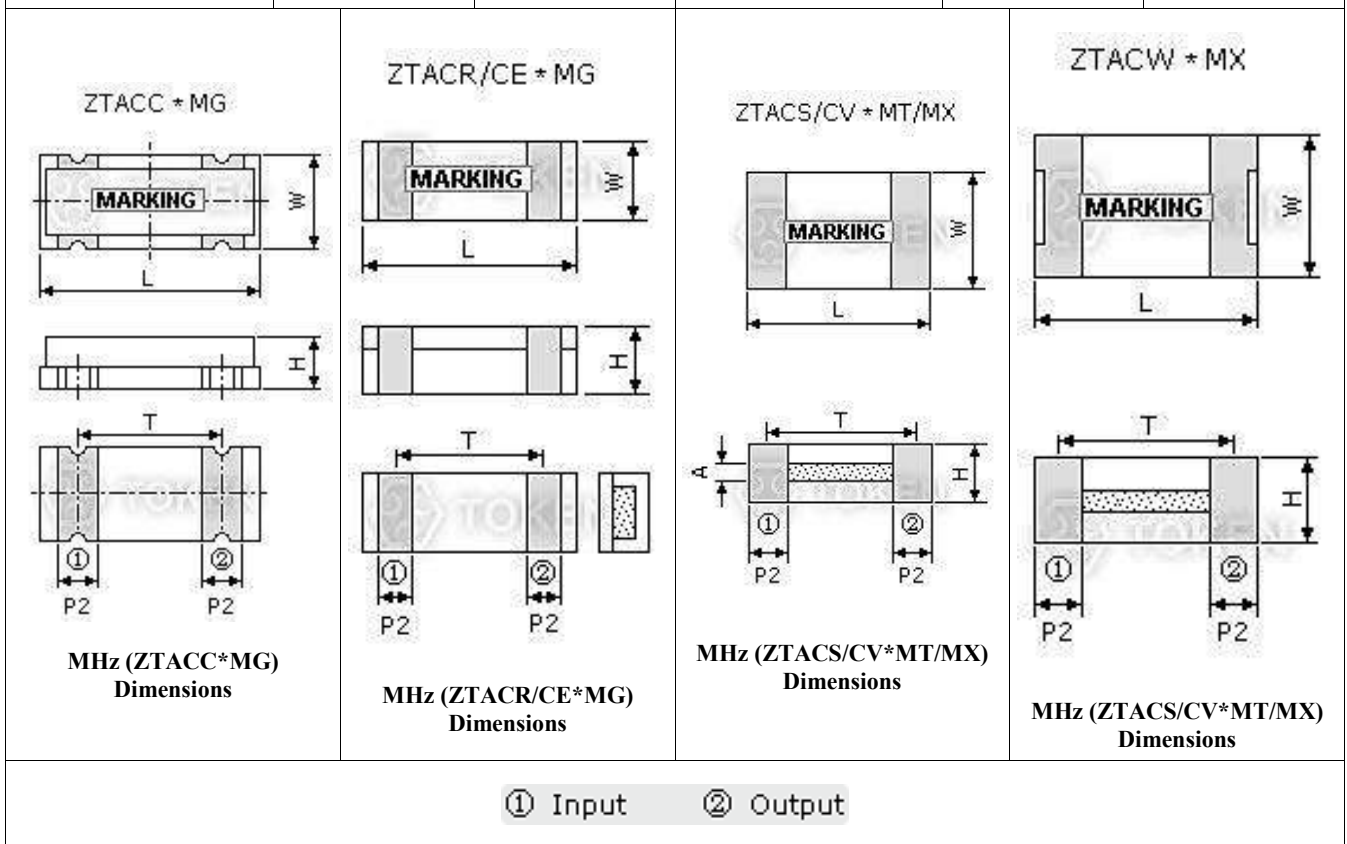

- Note: A stands for thickness of the ceramic element, which varies with the frequency. The range of the thickness is 0.1 to 0.7mm.

## ZTTC Dimensions

### Dimensions (ZTTC)

Part Number	Dimensions (Unit: mm)					
	L	W	H	P1	P2	T
ZTTC*MG	7.4±0.2	3.4±0.2	1.8±0.2	1.2±0.2	1.2±0.2	2.5±0.3
ZTTCR*MG	4.5±0.2	2.0±0.2	1.2max	0.8±0.2	0.8±0.2	1.5±0.2
ZTTCCE*MG	3.2±0.1	1.3±0.1	1.0max	0.4±0.1	0.4±0.1	1.2±0.1
ZTTC*MT/MX	4.7±0.2	4.1±0.2	(1.2+A)±0.2	1.0±0.2	0.8±0.2	1.95±0.2
ZTTCV*MT/MX	3.7±0.2	3.1±0.2	(1.0+A)±0.2	0.9±0.2	0.7±0.2	1.5±0.2
ZTTCW*MX	2.5±0.2	2.0±0.2	1.5max	0.5±0.2	0.4±0.2	1.0±0.2

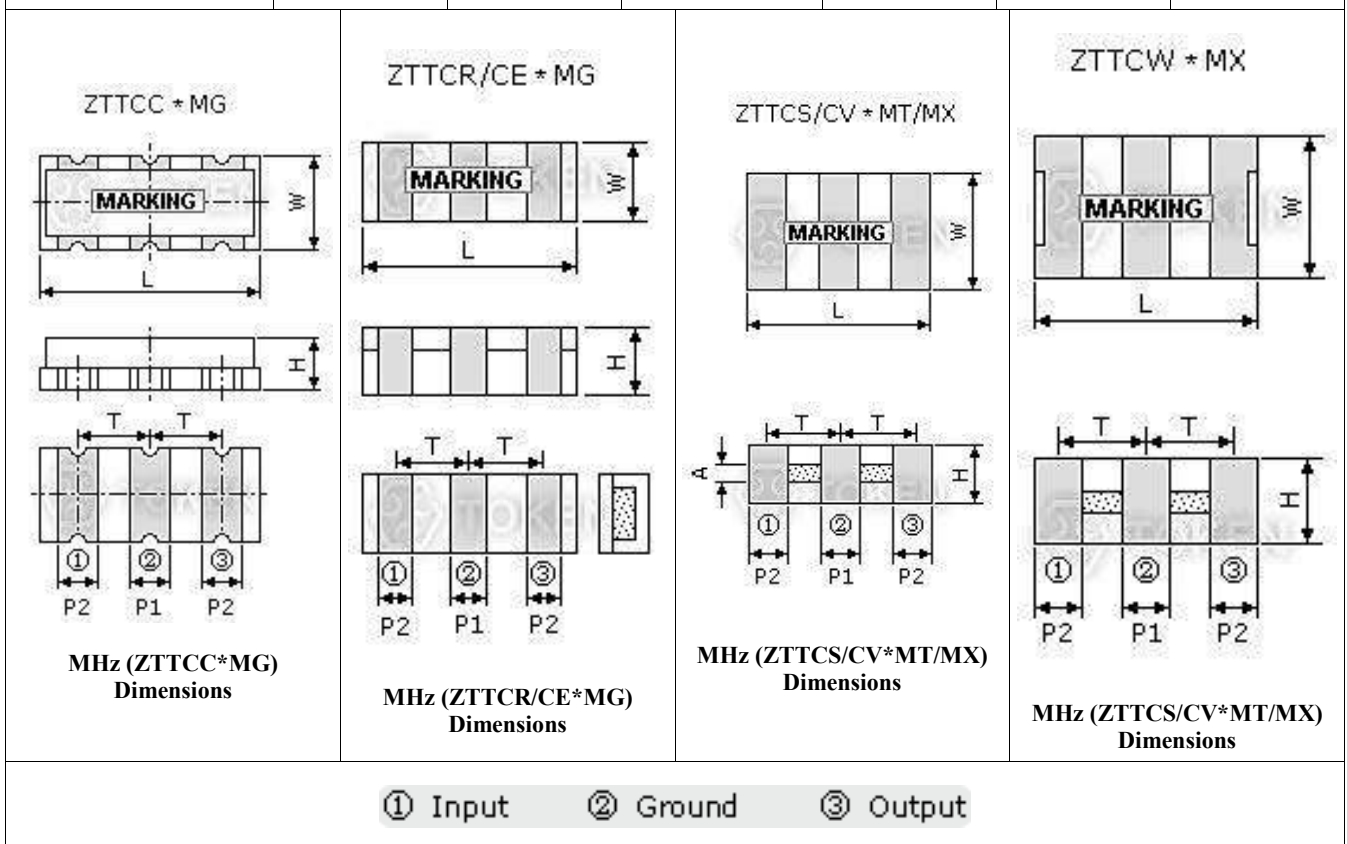

- Note: A stands for thickness of the ceramic element, which varies with the frequency. The range of the thickness is 0.1 to 0.7mm.

## ▶ Technical Characteristics

### Technical Characteristics (ZTAC/ZTTC)

Part Number	Frequency Range (MHz)	Frequency Accuracy (%)	Stability in Temperature (-20°C ~ +80°C) (%)	Aging for Ten Years (%)
ZTACC*MG / ZTCC*MG	1.79 ~ 8.00	± 0.5	± 0.3	± 0.3
ZTACR*MG / ZTTCR*MG	4.00 ~ 8.00	± 0.5	± 0.3	± 0.3
ZTACS*MT / ZTTCS*MT	6.00 ~ 13.00	± 0.5	± 0.4	± 0.3
ZTACV*MT / ZTTCV*MT	8.00 ~ 13.00	± 0.5	± 0.4	± 0.3
ZTACE*MG / ZTTCE*MG	8.00 ~ 13.00	± 0.5	± 0.4	± 0.3
ZTACS*MX / ZTTCS*MX	13.01 ~ 50.00	± 0.5	± 0.3	± 0.3
ZTACV*MX / ZTTCV*MX	16.00 ~ 50.00	± 0.5	± 0.3	± 0.3
ZTACW*MX / ZTTCW*MX	20.00 ~ 45.00	± 0.5	± 0.3	± 0.3





## ▶ Test Circuit for MOS IC

### Test Circuit for MOS IC (ZTAC/ZTTC)

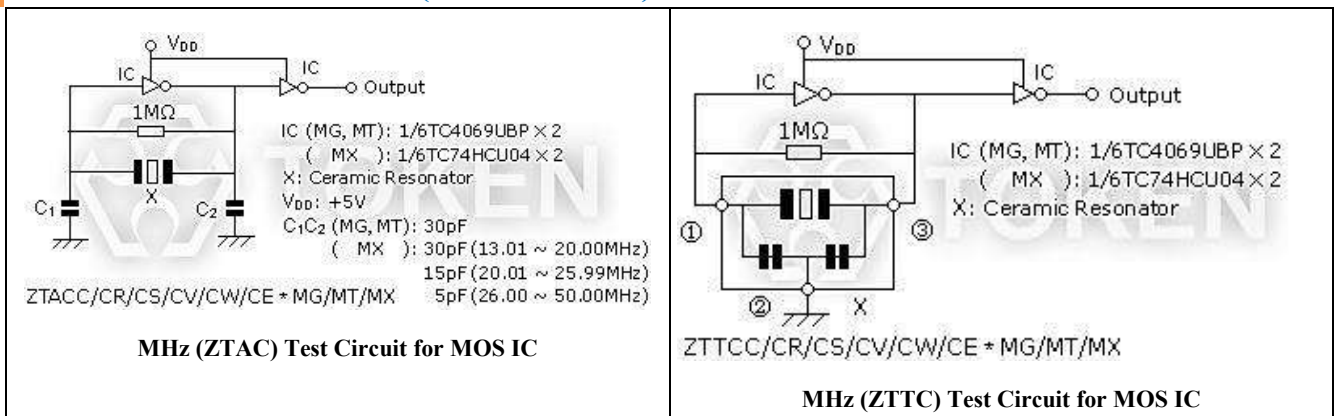

### (ZTAC/ZTTC) Resonator Application - Oscillation Circuit for MOS IC

#### Feedback Resistor ( $R = 1M\Omega$ ):

A Feedback Resistor is used to determine the oscillation circuit bias. The feedback resistance will contribute to instability if it is too large by reducing feedback. Conversely, if it is too small, increases in current will be realized thereby reducing gain. Recent developments in IC design allows for the integration of the feedback resistor in many cases.

#### Bias resistor ( $R_b$ optional):

A Bias Resistor can be utilized in the resonator oscillation circuit to change the bias point when a reduction in IC gain is required, or to suppress unstable oscillation. This may be especially considered when a 3 stage buffered IC, or TTL IC, is used.

#### Damping Resistor ( $R_d$ optional):

Abnormal harmonic oscillation can be suppressed using a dampening resistor. The dampening resistor and load capacitors work together as a low-pass filter to reduce gain in the MHz range of oscillation.

#### Loading Capacitor ( $C_1$ & $C_2$ )

The stability of the oscillation circuit is mainly determined by the  $C_1$  &  $C_2$  values. If the load capacitance is too small, unstable oscillation will occur because of oscillation waveform distortion. If too high, a stop in oscillation can be expected. When comparing the same IC, oscillation circuits with lower frequencies require higher capacitance. Token Engineers can help with the circuit design if needed.

### (ZTAC/ZTTC) Resonator Optimization - IC Evaluations

Tolerance is determined by the design of the resonator. However stability and correlation is determined by the IC evaluation. The microcontroller is evaluated with the resonators to determine the best possible circuit conditions to achieve stability and stable oscillation.

In addition, frequency correlation is measured to meet the tight initial frequency tolerance required. For the tight tolerance resonators the IC evaluation must be completed on the final circuit board layout. The final circuit boards provide the most accurate measurement of the frequency correlation.

This measurement will account for the effects of stray capacitance on the oscillation frequency. Once the correlation is determined the frequency of the resonator is adjusted to compensate for the correlation.

## Recommended Land Pattern

### Recommended Land Pattern (ZTAC/ZTTC)

Part Number	Dimensions (Unit: mm)			
	T1	T2	T3	W1
ZTACC*MG		1.7±0.3	5.0±0.3	4.0±0.3
ZTACR*MG		0.8±0.2	3.0±0.2	2.6±0.2
ZTACS*MT/MX		0.8±0.2	3.9±0.2	5.0±0.2
ZTACV*MT/MX		0.7±0.2	3.0±0.2	4.1±0.2
ZTACW*MX		0.5±0.2	2.0±0.2	2.6±0.2
ZTCC*MG	1.5±0.3	1.7±0.3	2.5±0.3	4.0±0.3
ZTCR*MG	0.8±0.2	0.8±0.2	1.5±0.2	2.6±0.2
ZTCS*MT/MX	1.3±0.2	0.8±0.2	1.95±0.2	5.0±0.2
ZTCV*MT/MX	1.0±0.2	0.7±0.2	1.5±0.2	4.1±0.2
ZTCW*MX	0.5±0.2	0.5±0.2	1.0±0.2	2.6±0.2

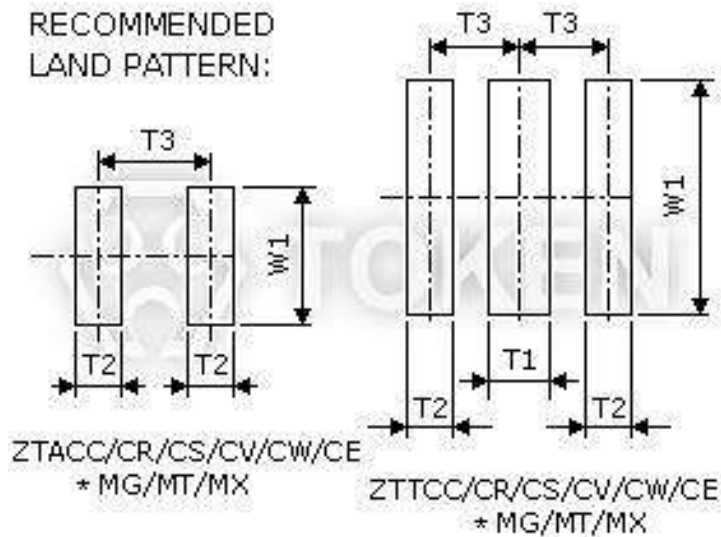

MHz (ZTAC/ZTTC) Recommended Land Pattern

## ▶ Order Codes

### Order Codes (ZTAC/ZTTC)

ZTACC5.00MG	TR
Part Number	Package
	Taping Reel

## ▶ General Information

### Token Cuts Resonator Size and Cost

Token's Resonators are made of high stability piezoelectric ceramics that function as a mechanical resonator. This device has been developed to function as a reference signal generator. The frequency is primarily adjusted by the size and thickness of the ceramic element. With the advance of the IC technology, various equipment may be controlled by a single LSI (Large-Scale Integration) integrated circuit, such as the one-chip microprocessor.

Resonator can be used as the timing element in most microprocessor based equipment. In the future, more and more applications will use **ceramic resonator** because of its high stability non-adjustment performance, miniature size and cost savings.

Typical applications include TVs, VCRs, remote controls and toys, voice synthesizers, automotive electronic devices, copiers, telephones, cameras, communication equipment.

Token offers a full range of industry standard through hole and surface mount resonators both with and without internal capacitors. For standard Operating Temperatures (-20°C to 80°C), and for Automotive applications (-40°C to +125°C), with a wide range of frequencies and frequency stability options. Additionally, Token Application Engineering and Design capabilities allow for custom design and characterization requirements that meet the demands of most applications.

