

Version:  
February 13, 2017



# TOKEN

## **(HVR) Thick Film High Voltage Chip Resistors**

**Token Electronics Industry Co., Ltd.**

**Taiwan:** No.137, Sec. 1, Zhongxing Rd., Wugu District,  
New Taipei City, Taiwan, R.O.C. 24872  
Tel: +886 2981 0109 Fax: +886 2988 7487

**China:** 12F, Zhong Xing Industry Bld., Chuang Ye Road,  
Nan Shan District, Shen Zhen City,  
Guang Dong, China 518054  
Tel: +86 755 26055363; Fax: +86 755 26055365

[Web: www.token.com.tw](http://www.token.com.tw)

<mailto:rfq@token.com.tw>



## ▶ Product Introduction

### ||| Thick-Film Chip Resistors operate at high voltages.

#### Features :

- Reduced size of final equipment
- Miniature size HVR02(0402) available
- Excellent performance at high voltage
- Higher component and equipment reliability
- Pb-free terminations meet RoHS requirements
- Thick film chips with highly reliable multi-layer electrode construction

#### Applications :

- Inverter, Converters
- Automatic Equipment Controller
- High-Voltage Power Supplies, Circuit Protection Devices
- Medical Equipment (Defibrillators, High Pulse Equipment)
- Printer Equipment, Consumer Product, Outdoor Equipments
- Military Equipment (Night Vision Cameras, X-ray Equipment)

#### New (HVR) High-voltage chip resistors deliver power ratings up to 4 KV.

Token electronics has introduced a thick-film chip resistor series with wide resistance range from 10Ω to 100MΩ. The (HVR) series of surface mount resistors feature high-voltage operation in standard 0402, 0603, 0805, 1206, 2010 and 2512 package sizes, making them well ideal for automatic handling methods.

The (HVR) resistors offer high voltage, extended surge ratings. This pulse-withstanding chip resistor combines extended surge values with high-voltage ratings for high-power applications. The (HVR) series are designed for use in high-voltage power supplies, circuit protection devices, medical equipment (defibrillators), military equipment (night vision cameras, x-ray equipment), automotive industry, and High Pulse Equipments.

Token's (HVR) series features high grade alumina substrate wrap-around terminations with an electroplated nickel barrier (Ni) with Edge Electrode (NiCr), and either tin/lead or RoHS-compliant matte tin finish. In addition, the overall robust construction allows the chip resistor to operate in harsh, high-voltage environments.

The (HVR) series feature tolerances of  $\pm 1\%$ , and  $\pm 5\%$ . Continuous voltage ratings are rated up to 3 KV, with maximum overload voltage to 4 KV. Power ratings for the HVR02 (0402), HVR03(0603), HVR05(0805), HVR06(1206), HVR0A(2010) and HVR12(2512) resistors are 1/16W, 1/10W, 1/8W, 1/4W, 1/2W and 1W, respectively, with an operating temperature range of  $-55^{\circ}\text{C}$  to  $+155^{\circ}\text{C}$ . Custom specifications are available.

The (HVR) series are available in taping packaging and RoHS compliant. For non-standard technical requirements and special applications, please contact us with your specific needs, or link to Token official website "[Chip Resistors](http://www.token.com.tw)" to get more information.



## Construction & Dimensions

### Construction & Dimensions (Unit: mm) (HVR)

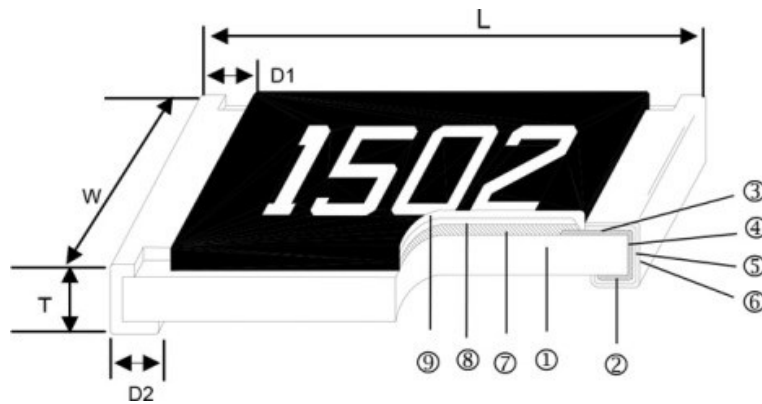

High Voltage Thick Film Chip Resistor Construction (HVR)

①	Alumina Substrate
②	Bottom Electrode
③	Top Electrode
④	Edge Electrode
⑤	Barrier Layer
⑥	External Electrode
⑦	Resistor Layer
⑧	Primary Overcoat
⑨	Secondary Overcoat

Type	L (Unit: mm)	W (Unit: mm)	T (Unit: mm)	D1 (Unit: mm)	D2 (Unit: mm)	Weight(g)/ 1000pcs
HVR02 (0402)	1.00±0.05	0.50±0.05	0.35±0.05	0.20±0.10	0.20±0.10	0.620
HVR03 (0603)	1.60±0.10	0.80±0.10	0.45±0.10	0.30±0.20	0.30±0.20	2.042
HVR05 (0805)	2.00±0.10	1.25±0.10	0.50±0.10	0.35±0.20	0.40±0.20	4.368
HVR06 (1206)	3.10±0.10	1.55±0.10	0.55±0.10	0.50±0.25	0.50±0.20	8.947
HVR0A (2010)	5.00±0.10	2.50±0.15	0.55±0.10	0.60±0.25	0.50±0.20	24.241
HVR12 (2512)	6.35±0.10	3.10±0.15	0.55±0.10	0.60±0.25	0.50±0.20	39.448

## Recommend Conditions

### Recommend Land Pattern (Unit: mm) (HVR)

Codes	A (mm)	B (mm)	C (mm)
HVR02 (0402)	0.50	0.45	0.60±0.2
HVR03 (0603)	0.90	0.60	0.90±0.2
HVR05 (0805)	1.20	0.70	1.30±0.2
HVR06 (1206)	2.00	0.90	1.60±0.2
HVR0A (2010)	3.80	0.90	2.80±0.2
HVR12 (2512)	3.80	1.60	3.50±0.2

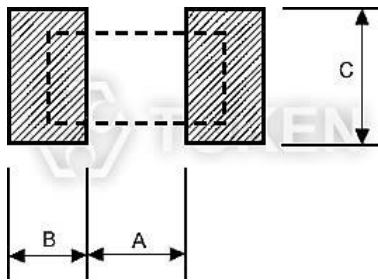

Recommend Land Pattern (HVR)

### Power Derating Curve (HVR)

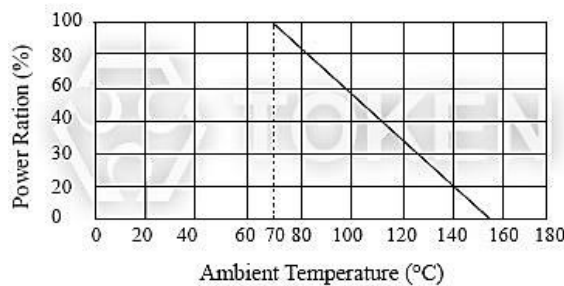

Power Derating Curve (HVR) Series

### Soldering Condition (PR)

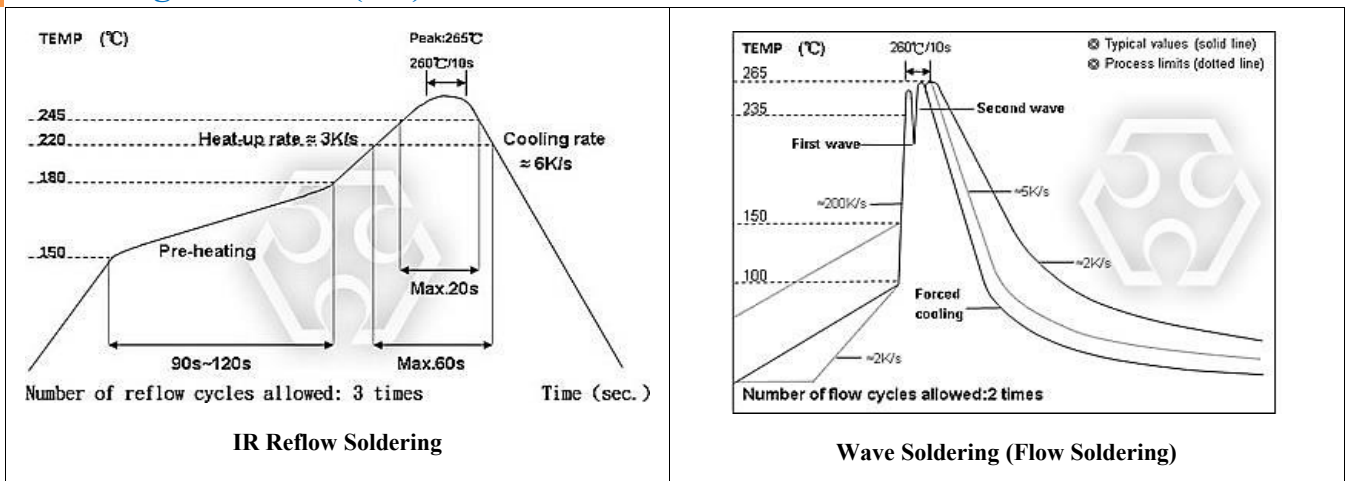

- (1) Time of IR reflow soldering at maximum temperature point 260°C : 10s
- (2) Time of wave soldering at maximum temperature point 260°C : 10s
- (3) Time of soldering iron at maximum temperature point 410°C : 5s

## Electrical Spec.

### Standard Electrical Specifications (HVR)

Type	Power Rating at 70°C	Operating Temp. Range	Max Operating Voltage	Max Overloading Voltage	Resistance Tolerance	Resistance Range	TCR
HVR02 (0402)	1/16W	-55 ~ +155°C	100V	200V	±1.0%, ±5.0%	39KΩ~1MΩ	±100PPM/°C
					±1.0%	1.02MΩ~10MΩ	±200PPM/°C
					±5.0%	1.1MΩ~20MΩ	±200PPM/°C
					±5.0%	22MΩ~100MΩ	±400PPM/°C
HVR03 (0603)	1/10W	-55 ~ +155°C	200V	400V	±1.0%, ±5.0%	56KΩ~1MΩ	±100PPM/°C
					±1.0%	1.02MΩ~10MΩ	±200PPM/°C
					±5.0%	1.1MΩ~20MΩ	±200PPM/°C
					±5.0%	22MΩ~100MΩ	±400PPM/°C
HVR05 (0805)	1/8W	-55 ~ +155°C	400V	800V	±1.0%, ±5.0%	100KΩ~1MΩ	±100PPM/°C
					±1.0%	1.02MΩ~10MΩ	±200PPM/°C
					±5.0%	1.1MΩ~20MΩ	±200PPM/°C
					±5.0%	22MΩ~100MΩ	±400PPM/°C
HVR06 (1206)	1/4W	-55 ~ +155°C	500V	1000V	±1.0%, ±5.0%	100KΩ~1MΩ	±100PPM/°C
					±1.0%	1.02MΩ~10MΩ	±200PPM/°C
					±5.0%	1.1MΩ~20MΩ	±200PPM/°C
					±5.0%	22MΩ~100MΩ	±400PPM/°C
HVR0A (2010)	1/2W	-55 ~ +155°C	2000V	3000V	±1.0%, ±5.0%	51KΩ~1MΩ	±100PPM/°C
					±1.0%	1.02MΩ~10MΩ	±200PPM/°C
					±5.0%	1.1MΩ~20MΩ	±200PPM/°C
					±5.0%	22MΩ~100MΩ	±400PPM/°C
HVR12 (2512)	1W	-55 ~ +155°C	3000V	4000V	±1.0%, ±5.0%	30KΩ~1MΩ	±100PPM/°C
					±1.0%	1.02MΩ~10MΩ	±200PPM/°C
					±5.0%	1.1MΩ~20MΩ	±200PPM/°C
					±5.0%	22MΩ~100MΩ	±400PPM/°C

- Lower Resistance :(1~10)Ω.
- Operating Voltage =  $\sqrt{P * R}$  , or Max. Operating Voltage listed in above table whichever is lower.
- Overloading Voltage =  $2.5 * \sqrt{P * R}$  , or Max. Overloading Voltage listed in above table whichever is lower.
- Optional specifications can be required.

## ► Environmental Characteristics

### Environmental Characteristics (HVR)

Item	Specification		Test Method
	Tol. 1%	Tol. 5%	
Dry Heat	$\pm(1\%+0.05\Omega)$	$\pm(1.5\%+0.10\Omega)$	JIS-C-5201-1 4.23 IEC-60115-1 4.23.2 At +155°C for 1000 hrs.
Endurance	$\pm(2\%+0.10\Omega)$	$\pm(3\%+0.10\Omega)$	JIS-C-5201-1 4.25 IEC-60115-1 4.25.1 70±2°C, Max. Working voltage for 1000 hrs with 1.5 hrs "ON" and 0.5 hrs "OFF".
Bending Strength	$\pm(1\%+0.05\Omega)$	$\pm(1\%+0.05\Omega)$	JIS-C-5201-1 4.33 IEC-60115-1 4.33 Bending once for 5 seconds, 2010, 2512 sizes: 2mm, other sizes: 3mm.
Short Time Overload	$\pm(1\%+0.05\Omega)$	$\pm(2\%+0.05\Omega)$	JIS-C-5201-1 4.13 IEC-60115-1 4.13 RCWV*2.5 or Max Overloading Voltage whichever is lower for 5 seconds.
Damp Heat with Load	$\pm(2\%+0.10\Omega)$	$\pm(3\%+0.10\Omega)$	JIS-C-5201-1 4.24 IEC-60115-1 4.24 40±2°C, 90~95% R.H. Max. Working voltage for 1000 hrs with 1.5 hrs "ON" and 0.5 hrs "OFF".
Resistance to Soldering Heat	$\pm(0.5\%+0.05\Omega)$	$\pm(1\%+0.05\Omega)$	JIS-C-5201-1 4.18 IEC-60115-1 4.18 260±5°C for 10 seconds.
Rapid Change of Temperature	$\pm(0.5\%+0.05\Omega)$	$\pm(1\%+0.05\Omega)$	JIS-C-5201-1 4.19 IEC-60115-1 4.19 -55°C to +155°C, 5 cycles.
Temperature Coefficient of Resistance	AS Spec		JIS-C-5201-1 4.8 IEC-60115-1 4.8 -55°C ~ +125°C, 25°C is the reference temperature.
Insulation Resistance	≥10GΩ		JIS-C-5201-1 4.6 IEC-60115-1 4.6 Max. Overload voltage for 1 minute.
Solderability	95% Min. coverage		JIS-C-5201-1 4.17 IEC-60115-1 4.17 245±5°C for 3 seconds.
Voltage Proof	No breakdown or flashover		JIS-C-5201-1 4.7 IEC-60115-1 4.7 HVR02: 150V for 1 minute; HVR03: 300V for 1 minute; HVR05/HVR06/HVR0A/HVR12: 500V for 1 minute
Leaching	Individual leaching area ≤5% total leaching area ≤10%		JIS-C-5201-1 4.18 IEC-60068-2-58 8.2.1 260±5°C for 30 seconds.

- Rated continuous Working Voltage (RCWV) =  $\sqrt{\text{Power Rating} \times \text{Resistance Value } (\Omega)}$  or Max. Operating voltage whichever is lower.
- Storage Temperature: 15~28°C; Humidity < 80%RH;



## ► Packaging & Reel Tape

### Packaging Quantity & Reel Specifications (Unit: mm) (HVR)

Codes	Packaging Quantity (KPCs)	Tape Width	Reel Diameter	ΦA (mm)	ΦB (mm)	ΦC (mm)	W (mm)	T (mm)	
HVR02	Paper	10K	8mm	7 inch	178.5±1.5	60 <sup>+1</sup>	13.0±0.2	9.0±0.5	12.5±0.5
		20K	8mm	10 inch	254±1	100±0.5	13.0±0.2	9.5±0.5	13.5±0.5
		40K	8mm	13 inch	330±1	100±0.5	13.0±0.2	9.5±0.5	13.5±0.5
HVR03 HVR05 HVR06	Paper	5K	8mm	7 inch	178.5±1.5	60 <sup>+1</sup>	13.0±0.2	9.0±0.5	12.5±0.5
		10K	8mm	10 inch	254±1	100±0.5	13.0±0.2	9.5±0.5	13.5±0.5
		20K	8mm	13 inch	330±1	100±0.5	13.0±0.2	9.5±0.5	13.5±0.5
HVR0A HVR12	Embossed	4K	12mm	7 inch	178.5±1.5	60 <sup>+1</sup>	13.0±0.5	13.0±0.5	15.5±0.5
		8K	12mm	10 inch	250±1	62±0.5	13.0±0.5	12.5±0.5	16.5±0.5

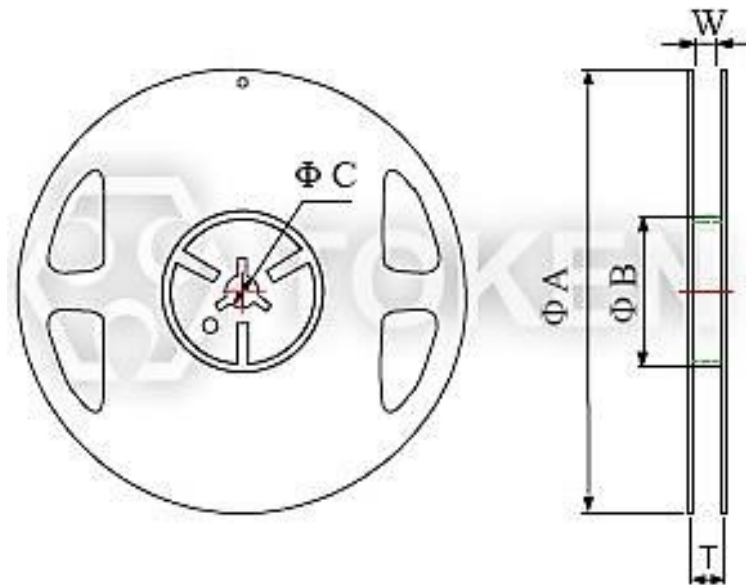

Reel Packaging (PR)

## Paper Tape Specifications (Unit: mm) (HVR)

Codes	A (mm)	B (mm)	W (mm)	E (mm)	F (mm)	P <sub>0</sub> (mm)	P <sub>1</sub> (mm)	P <sub>2</sub> (mm)	ΦD <sub>0</sub> (mm)	T (mm)
HVR02	0.65±0.10	1.15±0.10	8.0±0.20	1.75±0.10	3.50±0.05	4.00±0.10	2.00±0.05	2.00±0.05	1.50 <sup>+0.1</sup>	0.45±0.1
HVR03	1.10±0.10	1.90±0.1	8.0±0.2	1.75±0.1	3.50±0.05	4.00±0.10	4.00±0.05	2.00±0.05	1.50 <sup>+0.1</sup>	0.70±0.1
HVR05	1.60±0.10	2.40±0.2	8.0±0.2	1.75±0.1	3.50±0.05	4.00±0.10	4.00±0.05	2.00±0.05	1.50 <sup>+0.1</sup>	0.85±0.1
HVR06	1.90±0.10	3.50±0.2	8.0±0.2	1.75±0.1	3.50±0.05	4.00±0.10	4.00±0.05	2.00±0.05	1.50 <sup>+0.1</sup>	0.85±0.1

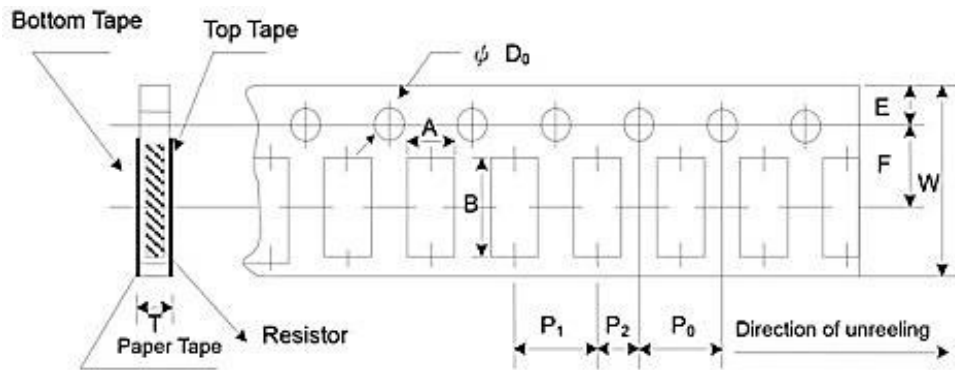

Paper Tape Specifications (HVR)

## Emboss Plastic Tape Specifications (Unit: mm) (HVR)

Codes	A (mm)	B (mm)	W (mm)	E (mm)	F (mm)	P <sub>0</sub> (mm)	P <sub>1</sub> (mm)	P <sub>2</sub> (mm)	ΦD <sub>0</sub> (mm)	T (mm)
HVR0A	2.8±0.10	5.5±0.10	12.0±0.3	1.75±0.1	5.5±0.05	4.00±0.10	4.00±0.1	2.00±0.05	1.50 <sup>+0.1</sup>	1.2
HVR12	3.5±0.10	6.7±0.10	12.0±0.3	1.75±0.1	5.5±0.05	4.00±0.10	4.00±0.1	2.00±0.05	1.50 <sup>+0.1</sup>	1.2

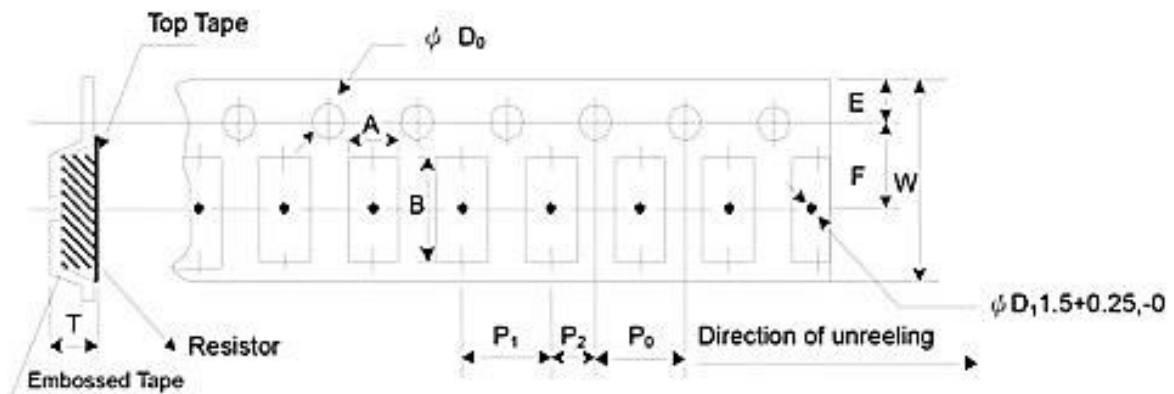

Embossed Plastic Tape (HVR)



## Order Codes

### Order Codes (HVR)

HVR	03	J	TR	E	V	1003
Part Number	Dimensions (L×W) (mm)	Resistance Tolerance (%)	Package	TCR (ppm/°C)	Power Rating(W)	Resistance (Ω)
02	EIA0402	F ±1 J ±5	TR Taping Reel	E ±100	T 1	4R70 4.7
03	EIA0603		P Bulk	F ±200	U 1/2	1000 100
05	EIA0805			H ±400	V 1/4	4700 470
06	EIA1206				W 1/8	4992 49.9K
0A	EIA2010				X 1/10	1003 100K
12	EIA2512				Y 1/16	1004 1M
						1005 10M

### 0805~2512 4 digits marking for Example Marking

Resistance	100Ω	2.2KΩ	10KΩ	49.9KΩ	100KΩ	1MΩ
Marking	1000	2201	1002	4992	1003	1004

### 0603: 3 digits Marking E24 Nominal Table

E24 code	10	11	12	13	15	16	18	20	22	24	27	30	33	36	39	43	47	51	56	62	68	75	82	91
----------	----	----	----	----	----	----	----	----	----	----	----	----	----	----	----	----	----	----	----	----	----	----	----	----

- Example: 101=100Ω 102=1KΩ (1st and 2nd are E24 code and 3rd code is multiplier)
- Resistance tolerance 1% for 0603: 3 digits marking in E96 (E96 series except E24 series)
- Digits marking for Example: 13C=13K3Ω; 68B=4K99Ω; 68X=49.9Ω

### Marking Table E96 Nominal Table

code	02	03	04	06	07	08	09	10	11	13	14	15	16	17	19	20	21	22	23	24	25	26	27
E96	102	103	107	113	115	118	121	124	127	133	137	140	143	147	154	158	162	165	169	174	178	182	187
code	28	29	31	32	33	34	35	36	37	38	39	40	41	42	43	44	45	46	47	48	49	50	51
E96	191	196	205	210	215	221	226	232	237	243	249	255	261	267	274	280	287	294	301	309	316	324	332
code	52	53	54	55	56	57	58	59	60	61	62	63	64	65	66	67	68	69	70	71	72	73	74
E96	340	348	357	365	374	383	392	402	412	422	432	442	453	464	475	487	499	511	523	536	549	562	576
code	75	76	77	78	79	80	81	82	83	84	86	87	88	89	90	91	92	93	94	95	96		
E96	590	604	619	634	649	665	681	698	715	732	768	787	806	825	845	866	887	909	931	953	976		

### Multiplier E96 Marking

Code	A	B	C	D	E	F	X	Y
Multiplier	10 <sup>0</sup>	10 <sup>1</sup>	10 <sup>2</sup>	10 <sup>3</sup>	10 <sup>4</sup>	10 <sup>5</sup>	10 <sup>-1</sup>	10 <sup>-2</sup>

### ► General Information

#### **Token Thin Film Chips Add Powerful New Options**

Token electronics provides the industry's most comprehensive range of precision thin film technologies for discrete, network, and integrated passive components used in instrumentation; automotive electronics; communications systems; and portable electronics applications. Ultra-reliable precision Nichrome resistive elements are available on ceramic or silicon substrates in a wide variety of surface mount resistors.

In response to market demands for increased precision and stability, Token has expanded range of nichrome thin-film chip resistors. Offering solutions to precision test and measurement and voltage regulation across industrial, military and medical monitoring equipment markets designed to offer superior humidity performance.

#### **Token Thick Film Chips Cut the Cost of Precision Resistors**

Token electronics has developed an extensive range of thick film / thin film resistive technologies for electronic circuits in power supplies; test and measurement; industrial electronics; telecommunications; audio circuits; automotive control systems; lighting controls; medical electronics; industrial equipment; and control systems applications.

In addition to this, proven thick film technologies from Token electronics provide a large range of standard resistive low Ohmic current sense products for critical battery management, and line termination. The enhanced performance of the chips is made possible by the precise use of the best resistance inks and a closely controlled production process.

#### **Token Chip Low Ohmic Resistors come in Smaller Sizes and Minimized Power Consumption**

Today's electronic devices are becoming smaller and smaller. As a result, designers are moving more towards surface mount components not only for new designs but also to design out large axial and other through-hole resistors.

In most cases this is a straight forward task as several resistor manufacturers offer chip resistors with performances to match axial parts. However in some cases, due to power rating or pulse withstanding requirements, this has been impossible. The requirement, in particular, for pulse withstand capability is growing due to the need to protect sensitive modern electronic systems. To meet this demand Token electronics have designed a Pulse Withstanding Chip Resistor (PWR Series).

