

Version:  
January 12, 2017



# TOKEN

(AR)

## Precision Chip Resistor

**Token Electronics Industry Co., Ltd.**

**Taiwan:** No.137, Sec. 1, Zhongxing Rd., Wugu District,  
New Taipei City, Taiwan, R.O.C. 24872  
Tel: +886 2981 0109 Fax: +886 2988 7487

**China:** 12F, Zhong Xing Industry Bld., Chuang Ye Road,  
Nan Shan District, Shen Zhen City,  
Guang Dong, China 518054  
Tel: +86 755 26055363; Fax: +86 755 26055365

[Web: www.token.com.tw](http://www.token.com.tw)

<mailto:rfq@token.com.tw>



**▶ Product Introduction**

**Token's thin-film precision chip resistors (AR)  
take accuracy pole position and add powerful new options.**

**Features :**

- Miniature Size 0201 available
- Thin Film Passivated NiCr Chips
- Very Tight Tolerance Down to  $\pm 0.01\%$
- Wide Resistance Value Range 1  $\Omega$  - 3Mega  $\Omega$
- Extremely Low TCR Down to  $\pm 2\text{PPM}/^\circ\text{C}$
- Products with Pb-free Terminations Meet RoHS Requirements

**Applications :**

- Converters
- Medical Equipment
- Automatic Equipment Controller
- Testing / Measurement Equipment
- Printer Equipment, Consumer Product
- Communication Device, Cell phone, GPS, PDA

In response to market demands for increased precision and stability, Token Passive Components has expanded its AR Series of nichrome thin-film chip resistors into three sectors, Standard, High-Precision, and High-Power resistor.

Offering a wide value range with closer tolerances and low TCR figures, Token offers a surface mount resistor with a defined total contour that provides high stability under temperature fluctuations of  $2\text{ppm}/^\circ\text{C}$  and with a tolerance down to  $\pm 0.01\%$ .

The AR Series offering solutions to precision test and measurement and voltage regulation across industrial, military and medical monitoring equipment markets proposing superior tight tolerance, low TCR, and high power rating performance.

The range now also offers additional chip sizes. Key features of the enhanced AR Series include the availability of all standard sizes from AR01(0201), AR02(0402), AR03(0603), AR05(0805), AR06(1206), AR13(1210), AR10(2010), to AR12(2512).

The AR benefits from an impervious internal passivation layer applied in addition to the normal protective coating. When constructing the AR Chip Series, a Ni/Cr thin-film material is selectively deposited on an alumina substrate, together with Ni and Sn metallic contacts at each end layer plating. The AR chips are heat treated to give the required temperature coefficient (TCR) and stability, and then a precisely controlled laser trim process adjusts the resistance value.

The AR Series is available in taping packaging and is RoHS compliant and lead free. For non-standard technical requirements and special applications, please contact us with your specific needs, or link to Token official website "[Chip Resistors](http://www.token.com.tw)" to get more information.



## Dimensions

### Dimensions (Unit: mm) (AR)

Codes	L (Unit: mm)	W (Unit: mm)	T (Unit: mm)	D1 (Unit: mm)	D2 (Unit: mm)	Weight (g) (1000pcs)
AR01 (0201)	0.58±0.05	0.29±0.05	0.23±0.05	0.12±0.05	0.15±0.05	0.14
AR02 (0402)	1.00±0.05	0.50±0.05	0.30±0.05	0.20±0.10	0.20±0.10	0.54
AR03 (0603)	1.55±0.10	0.80±0.10	0.45±0.10	0.30±0.20	0.30±0.20	1.83
AR05 (0805)	2.00±0.15	1.25±0.15	0.55±0.10	0.30±0.20	0.40±0.25	4.71
AR06 (1206)	3.05±0.15	1.55±0.15	0.55±0.10	0.42±0.20	0.35±0.25	9.02
AR13 (1210)	3.10±0.15	2.40±0.15	0.55±0.10	0.40±0.20	0.55±0.25	10
AR10 (2010)	4.90±0.15	2.40±0.15	0.55±0.10	0.60±0.30	0.50±0.25	23.61
AR12 (2512)	6.30±0.15	3.10±0.15	0.55±0.10	0.60±0.30	0.50±0.25	38.06

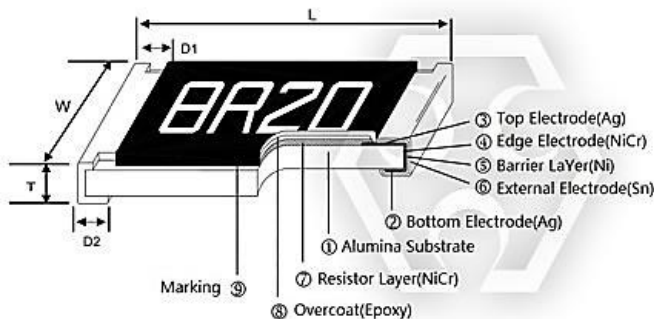

Precision Chip (AR) Construction

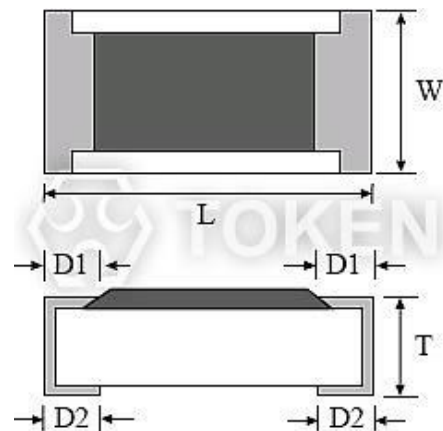

Precision Chip (AR) Dimensions

## Electrical Spec.

### Standard Electrical Specifications (AR)

Type	Power Rating at 70°C	Operating Temp. Range	Max Operating Voltage	Max Overloading Voltage	Resistance Tolerance (%)	Resistance Range (Ω)	TCR PPM/°C
AR01 (0201)	1/32W	-55 ~ +155°C	15V	30V	±0.5%	49.9~4.99K	±25
					±1%	49.9~33K	±50
AR02 (0402)	1/16W	-55 ~ +155°C	25V	50V	±0.05%	49.9~12K	±25, ±50
					±0.1%	10~255K	
					±0.25%, ±0.5%, ±1%	4.7~511K	
AR03 (0603)	1/16W	-55 ~ +155°C	50V	100V	±0.05%	4.7~332K	±25, ±50
					±0.1%	4.7~1M	
					±0.25%, ±0.5%, ±1%	1~1M	
AR05 (0805)	1/10W	-55 ~ +155°C	100V	200V	±0.05%	4.7~1M	±25, ±50
					±0.1%	4.7~2M	
					±0.25%, ±0.5%, ±1%	1~2M	
AR06 (1206)	1/8W	-55 ~ +155°C	150V	300V	±0.05%	4.7~1M	±25, ±50
					±0.1%	4.7~2.49M	
					±0.25%, ±0.5%, ±1%	1~2.49M	
AR13 (1210)	1/4W	-55 ~ +155°C	150V	300V	±0.05%	4.7~1M	±25, ±50
					±0.1%	4.7~2.49M	
					±0.25%, ±0.5%, ±1%	1~2.49M	
AR10 (2010)	1/4W	-55 ~ +155°C	150V	300V	±0.05%	4.7~1M	±25, ±50
					±0.1%	4.7~3M	
					±0.25%, ±0.5%, ±1%	1~3M	
AR12 (2512)	1/2W	-55 ~ +155°C	150V	300V	±0.05%	4.7~1M	±25, ±50
					±0.1%	4.7~3M	
					±0.25%, ±0.5%, ±1%	1~3M	

- Lower Resistance :( 1~10)Ω.
- Operating Voltage =  $\sqrt{(P * R)}$  , or Max. Operating Voltage listed in above table whichever is lower.
- Overloading Voltage =  $2.5 * \sqrt{(P * R)}$  , or Max. Overloading Voltage listed in above table whichever is lower.
- Optional specifications can be required.

## High-Precision Electrical Specifications (AR)

Type	Power Rating at 70°C	Operating Temp. Range	Max Operating Voltage	Max Overloading Voltage	Resistance Tolerance (%)	Resistance Range (Ω)	TCR PPM/°C
AR02 (0402)	1/16W	-55 ~ +155°C	25V	50V	±0.01%, ±0.05%, ±0.1%	49.9 ~4.99K	±2, ±3
					±0.01%, ±0.05%, ±0.1%, ±0.25%, ±0.5%, ±1%	49.9~4.99K	±5
					±0.01%, ±0.05%	49.9~12K	±10, ±15
					±0.1%, ±0.25%, ±0.5%, ±1%	49.9~60K	±10
					±0.1%, ±0.25%, ±0.5%, ±1%	49.9~69.8K	±15
AR03 (0603)	1/16W	-55 ~ +155°C	50V	100V	±0.01%, ±0.05%, ±0.1%	24.9~15K	±2, ±3
					±0.01%, ±0.05%, ±0.1%, ±0.25%, ±0.5%, ±1%	24.9~15K	±5
					±0.01%	24.9~100K	±10, ±15
					±0.05%	4.7~332K	±10, ±15
AR05 (0805)	1/10W	-55 ~ +155°C	100V	200V	±0.01%, ±0.05%, ±0.1%	24.9~30K	±2, ±3
					±0.01%, ±0.05%, ±0.1%, ±0.25%, ±0.5%, ±1%	24.9~30K	±5
					±0.01	24.9~200K	±10, ±15
					±0.05%, ±0.1%, ±0.25%, ±0.5%, ±1%	4.7~1M	±10, ±15
AR06 (1206)	1/8W	-55 ~ +155°C	150V	300V	±0.01%, ±0.05%, ±0.1%	24.9~49.9K	±2, ±3
					±0.01%, ±0.05%, ±0.1%, ±0.25%, ±0.5%, ±1%	24.9~49.9K	±5
					±0.01%	24.9~499K	±10, ±15
					±0.05%, ±0.1%, ±0.25%, ±0.5%, ±1%	4.7~1MK	±10, ±15
AR13 (1210)	1/4W	-55 ~ +155°C	150V	300V	±0.01%, ±0.05%, ±0.1%	24.9~49.9K	±2, ±3
					±0.01%, ±0.05%, ±0.1%, ±0.25%, ±0.5%, ±1%	24.9~49.9K	±5
					±0.01%	24.9~499K	±10, ±15
					±0.05%, ±0.1%, ±0.25%, ±0.5%, ±1%	4.7~1M	±10, ±15
AR10 (2010)	1/4W	-55 ~ +155°C	150V	300V	±0.01%, ±0.05%, ±0.1%	24.9~100K	±2, ±3
					±0.01%, ±0.05%, ±0.1%, ±0.25%, ±0.5%, ±1%	24.9~100K	±5
					±0.01%	24.9~499K	±10, ±15
					±0.05%, ±0.1%, ±0.25%, ±0.5%, ±1%	4.7~1M	±10, ±15
AR12 (2512)	1/2W	-55 ~ +155°C	150V	300V	±0.01%, ±0.05%, ±0.1%	24.9~100K	±2, ±3
					±0.01%, ±0.05%, ±0.1%, ±0.25%, ±0.5%, ±1%	24.9~100K	±5
					±0.01%	24.9~499K	±10, ±15
					±0.05%, ±0.1%, ±0.25%, ±0.5%, ±1%	4.7~1M	±10, ±15

- Lower Resistance :(1~10)Ω.
- Operating Voltage =  $\sqrt{(P * R)}$  , or Max. Operating Voltage listed in above table whichever is lower.
- Overloading Voltage =  $2.5 * \sqrt{(P * R)}$  , or Max. Overloading Voltage listed in above table whichever is lower.
- Optional specifications can be required.

## High-Power Rating Electrical Specifications (AR)

Type	Power Rating at 70°C	Operating Temp. Range	Max Operating Voltage	Max Overloading Voltage	Resistance Tolerance (%)	Resistance Range (Ω)	TCR PPM/°C
AR03 (0603)	1/10W	-55 ~ +155°C	75V	150V	±0.01%, ±0.05%, ±0.1%	24.9~15K	±2, ±3
					±0.01%, ±0.05%, ±0.1%, ±0.25%, ±0.5%, ±1%	24.9~15K	±5
					±0.01%	24.9~100K	±10, ±15, ±25, ±50
					±0.05%	4.7~332K	±10, ±15, ±25, ±50
					±0.1%, ±0.25%, ±0.5%, ±1%	4.7~332K	±10, ±15
	±0.1%, ±0.25%, ±0.5%, ±1%	4.7~1M	±25, ±50				
1/6W	-55 ~ +155°C	100V	150V	±0.05%, ±0.1%, ±0.25%, ±0.5%, ±1%	10~332K	±25, ±50	
AR05 (0805)	1/8W	-55 ~ +155°C	150V	300V	±0.01%, ±0.05%, ±0.1%	24.9~30K	±2, ±3
					±0.01%, ±0.05%, ±0.1%, ±0.25%, ±0.5%, ±1%	24.9~30K	±5
					±0.01%	24.9~200K	±10, ±15, ±25, ±50
					±0.05%	4.7~511K	±10, ±15, ±25, ±50
					±0.1%, ±0.25%, ±0.5%, ±1%	4.7~511K	±10
					±0.1%, ±0.25%, ±0.5%, ±1%	4.7~1M	±15
	±0.1%	4.7~1M	±25, ±50				
	±0.25%, ±0.5%, ±1%	1~1M	±25, ±50				
1/4W	-55 ~ +155°C	150V	300V	±0.05%, ±0.1%, ±0.25%, ±0.5%, ±1%	10~499K	±25, ±50	
AR06 (1206)	1/4W	-55 ~ +155°C	200V	400V	±0.01%, ±0.05%, ±0.1%	24.9~49.9K	±2, ±3
					±0.01%, ±0.05%, ±0.1%, ±0.25%, ±0.5%, ±1%	24.9~49.9K	±5
					±0.01%	24.9~499K	±10, ±15, ±25, ±50
	±0.05%, ±0.1%, ±0.25%, ±0.5%, ±1%	4.7~1M	±10, ±15, ±25, ±50				
1/3W	-55 ~ +155°C	200V	400V	±0.05%, ±0.1%, ±0.25%, ±0.5%, ±1%	10~1M	±25, ±50	
AR13 (1210)	1/3W	-55 ~ +155°C	200V	400V	±0.01%, ±0.05%, ±0.1%	24.9~49.9K	±2, ±3
					±0.01%, ±0.05%, ±0.1%, ±0.25%, ±0.5%, ±1%	24.9~49.9K	±5
					±0.01%	24.9~499K	±10, ±15, ±25, ±50
					±0.05%, ±0.1%, ±0.25%, ±0.5%, ±1%	4.7~1M	±10, ±15, ±25, ±50
AR10 (2010)	1/3W	-55 ~ +155°C	200V	400V	±0.01%, ±0.05%, ±0.1%	24.9~49.9K	±2, ±3
					±0.01%, ±0.05%, ±0.1%, ±0.25%, ±0.5%, ±1%	24.9~49.9K	±5
					±0.01%	24.9~499K	±10, ±15, ±25, ±50
					±0.05%, ±0.1%, ±0.25%, ±0.5%, ±1%	4.7~1M	±10, ±15, ±25, ±50
AR12 (2512)	3/4W	-55 ~ +155°C	200V	400V	±0.01%	24.9~2K	±10, ±15, ±25, ±50
					±0.05%, ±0.1%	4.7~2K	±10, ±15, ±25, ±50
					±0.25%, ±0.5%, ±1%	1~2K	±10, ±15, ±25, ±50
	1W	-55 ~ +155°C	200V	400V	±0.1%	4.7~100	±25, ±50
				±0.25%, ±0.5%, ±1%	1~100	±25, ±50	

- Lower Resistance :( 1~10)Ω.
- Operating Voltage =  $\sqrt{(P * R)}$  , or Max. Operating Voltage listed in above table whichever is lower.
- Overloading Voltage =  $2.5 * \sqrt{(P * R)}$  , or Max. Overloading Voltage listed in above table whichever is lower.
- Optional specifications can be required.

## Environmental Characteristics

### Environmental Characteristics (AR)

Item	Specification		Test Method
	Tol.≤0.05%	Tol.>0.05%	
Temperature Coefficient of Resistance	AS Spec		MIL-STD-202F Method 304 +25/-55/+25/+125/+25°C
Short Time Overload	ΔR±0.05%	ΔR±0.5%	JIS-C-5202-5.5
	ΔR±0.5% for high power rating		RCWV*2.5 or Max Overloading Voltage whichever is lower for 5 seconds.
Dielectric Withstand Voltage	By type		MIL-STD-202F Method 301 Apply Max Overload Voltage for 1 minute
Insulation Resistance	>1000M Ω		MIL-STD-202F Method 302 Apply 100VDC for 1minute
Thermal Shock	ΔR±0.05%	ΔR±0.25%	MIL-STD-202F Method 107G -55°C~150°C, 100cycles
Load Life (Endurance)	ΔR±0.05%	ΔR±0.2%	MIL-STD-202F Method 108A
	>7KΩ ΔR±0.5%		RCWV, 70°C, 1.5 hours ON, 0.5 hours OFF, 1000 hours
	ΔR±0.5% for high power rating		
humidity (Steady State ) (Damp Heat with Load)	ΔR±0.05%	ΔR±0.3%	MIL-STD-202F Method 103B
	ΔR±0.5% for high power rating		40°C, 90~95%RH, RCWV 1.5 hours ON, 0.5 hours OFF, total 1000 hours
Resistance to dry heat	ΔR±0.05%	ΔR±0.2%	JIS-C-5202-7.2 96 hours @ +155°C without load
Low Temperature Operation	ΔR±0.05%	ΔR±0.2%	JIS-C-5202-7.1
	ΔR±0.5% for high power rating		1 hour, -65°C, followed by 45minutes of RCWV
Bending Strength	ΔR±0.05%	ΔR±0.2%	JIS-C-5202-6.1.4 Bending Amplitude 3mm for 10seconds
Solderability	95%min coverage		MIL-STD-202F Method 208H 245°C±5°C, 2±0.5(sec)
Resistance to Soldering Heat	ΔR±0.05%	ΔR±0.2%	MIL-STD-202F Method 210E 260±5°C, 10±1 second

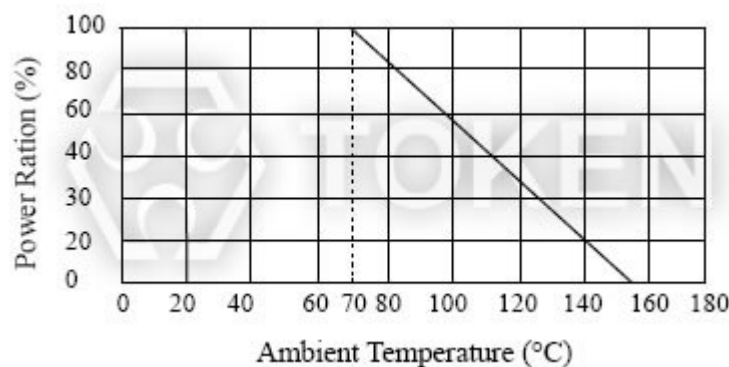

Power Derating Curve (AR)

- Rated continuous Working Voltage (RCWV) =  $\sqrt{\text{Power Rating} \times \text{Resistance Value } (\Omega)}$  or Max. Operating voltage whichever is lower.
- Storage Temperature: 15~28°C; Humidity < 80%RH;



## Recommend

### Recommend Land Pattern (Unit: mm) (AR)

Codes	A	B	C
AR12	4.90	1.60	3.10±0.2
AR10	3.60	1.40	2.50±0.2
AR13	2.00	1.15	2.50±0.2
AR06	2.00	1.15	1.70±0.2
AR05	1.00	1.00	1.35±0.2
AR03	0.80	1.00	0.90±0.2
AR02	0.50	0.50	0.60±0.2
AR01	0.25	0.30	0.40±0.2

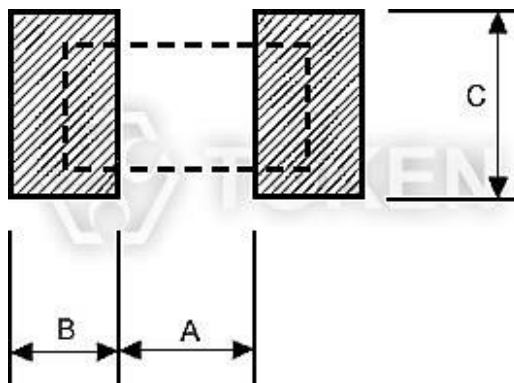

Recommend Land Pattern (AR)

### Recommend Soldering Condition (AR)

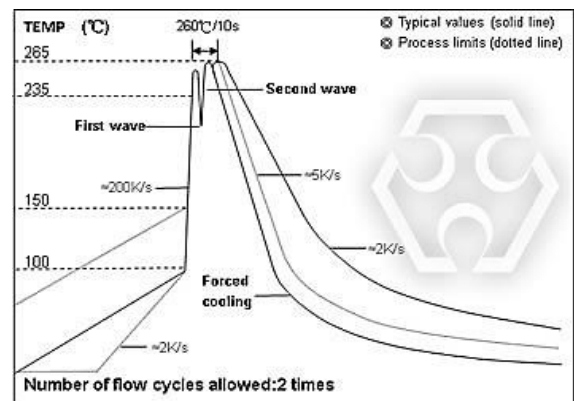
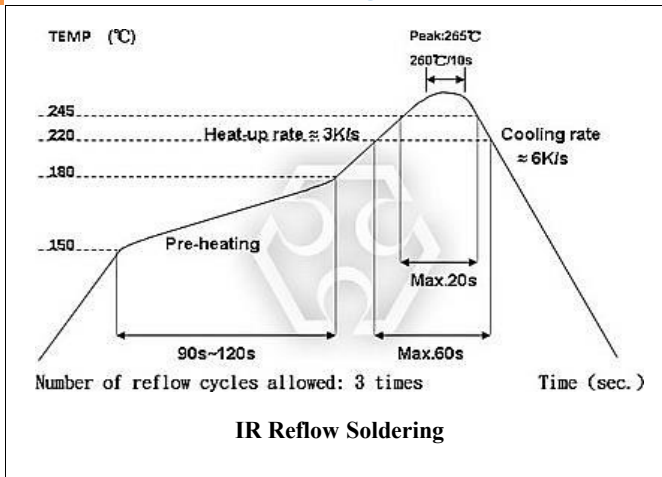

- (1) Time of IR reflow soldering at maximum temperature point 260°C : 10s
- (2) Time of wave soldering at maximum temperature point 260°C : 10s
- (3) Time of soldering iron at maximum temperature point 410°C : 5s



## ► Packaging & Reel Tape

### Packaging Quantity & Reel Specifications (Unit: mm) (AR)

Codes	ΦA	ΦB	ΦC	W	T	Paper Tape(PCS)	Emboss Plastic Tape (PCS)
AR01	178.0±1.0	60.0±1.0	13.5±0.7	9.5±1.0	11.5±1.0	10,000	-
AR02	178.0±1.0	60.0±1.0	13.5±0.7	9.5±1.0	11.5±1.0	10,000	-
AR03	178.0±1.0	60.0±1.0	13.5±0.7	9.5±1.0	11.5±1.0	5,000	-
AR05	178.0±1.0	60.0±1.0	13.5±0.7	9.5±1.0	11.5±1.0	5,000	-
AR06	178.0±1.0	60.0±1.0	13.5±0.7	9.5±1.0	11.5±1.0	5,000	-
AR13	178.0±1.0	60.0±1.0	13.5±0.7	9.5±1.0	11.5±1.0	5,000	-
AR10	178.0±1.0	60.0±1.0	13.5±0.7	13.5±1.0	15.5±1.0	-	4,000
AR12	178.0±1.0	60.0±1.0	13.5±0.7	13.5±1.0	15.5±1.0	-	4,000

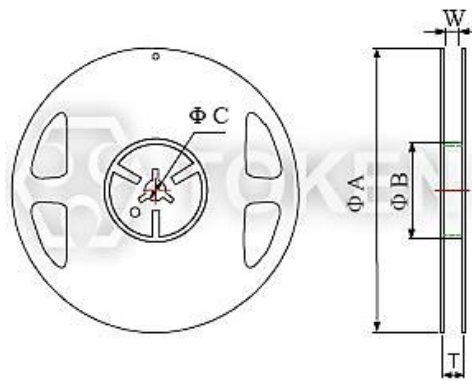

Reel Packaging (AR)

### Paper Tape Specifications (Unit: mm) (AR)

Codes	A	B	W	E	F	P0	P1	P2	ΦD0	T
AR01	0.40±0.05	0.70±0.05	8.00±0.10	1.75±0.05	3.5±0.05	4.00±0.10	2.00±0.05	2.00±0.05	1.55±0.05	0.265±0.05
AR02	0.70±0.05	1.16±0.05	8.00±0.10	1.75±0.05	3.5±0.05	4.00±0.10	2.00±0.05	2.00±0.05	1.55±0.05	0.40±0.03
AR03	1.10±0.05	1.90±0.05	8.00±0.10	1.75±0.05	3.5±0.05	4.00±0.10	4.00±0.10	2.00±0.05	1.55±0.05	0.60±0.03
AR05	1.60±0.05	2.37±0.05	8.00±0.10	1.75±0.05	3.5±0.05	4.00±0.10	4.00±0.10	2.00±0.05	1.55±0.05	0.75±0.05
AR06	2.00±0.05	3.55±0.05	8.00±0.10	1.75±0.05	3.5±0.05	4.00±0.10	4.00±0.10	2.00±0.05	1.55±0.05	0.75±0.05
AR13	2.75±0.05	3.40±0.05	8.00±0.10	1.75±0.05	3.5±0.05	4.00±0.10	4.00±0.10	2.00±0.05	1.60±0.10	0.75±0.05

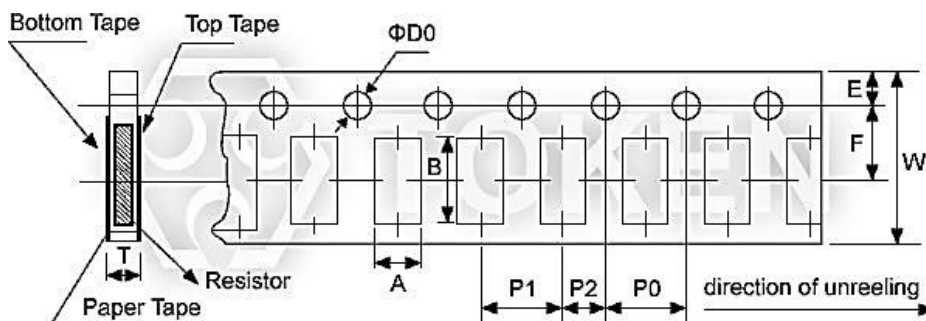

Thin Film Precision Chip Resistors (AR) Paper Tape Specifications

## Emboss Plastic Tape Specifications (Unit: mm) (AR)

Codes	A	B	W	E	F	P0	P1	P2	ΦD0	T
AR10	2.85±0.10	5.45±0.10	12.0±0.10	1.75±0.10	5.5±0.05	4.00±0.05	4.00±0.10	2.00±0.05	1.50±0.10	1.00±0.20
AR12	3.40±0.10	6.65±0.10	12.0±0.10	1.75±0.10	5.5±0.05	4.00±0.05	4.00±0.10	2.00±0.05	1.50±0.10	1.00±0.20

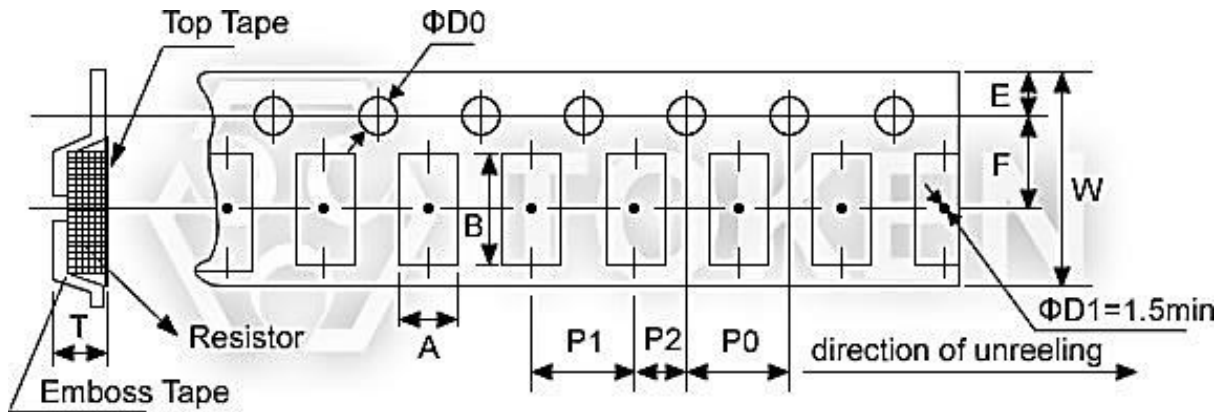

Surface Mount (AR) Emboss Plastic Tape Specifications

## Tape Peel Force (AR)

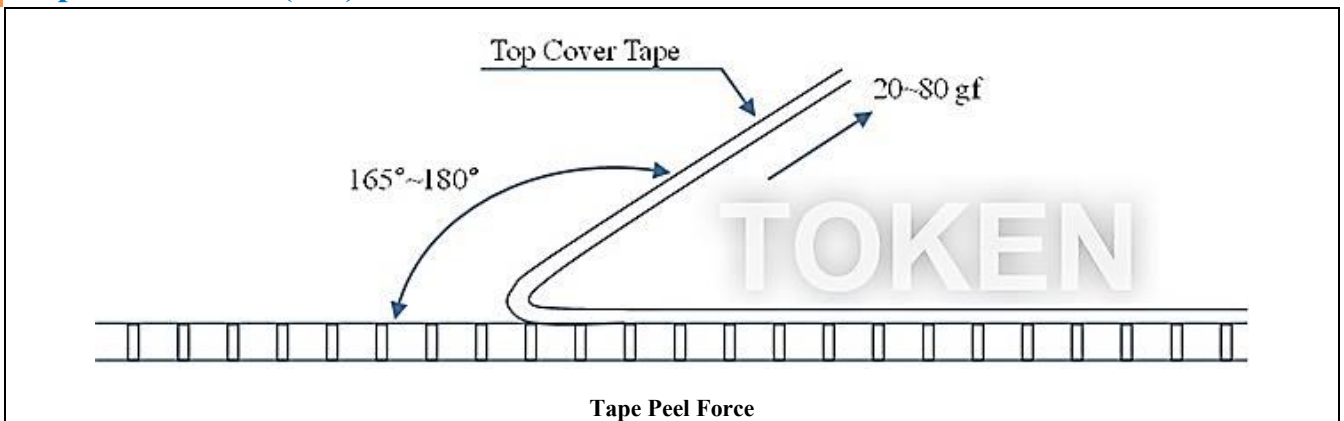

- (1) Peel force of top cover tape.
- (2) The peel speed shall be about 300 mm/min±5%
- (3) The peel force of top cover tape shall be between 20gf to 80gf.

## Order Codes

### Order Codes (AR)

AR	05	B	TR	C3	X	4700							
Part Number	Dimensions (L×W) (mm)	Resistance Tolerance(%)		Package		TCR (ppm/°C)		Power Rating(W)		Resistance (Ω)		Marking	
		P	Bulk	TR	Taping Reel	C7	±5	T	1W	4R70	4.7	N	Standard Marking for E96/E24
01	EIA0201	T	±0.01										
02	EIA0402	A5	±0.05	C5	±15	O	1/3	4700	470				
03	EIA0603	B	±0.10	C3	±25	V	1/4	4992	49.9K	No Marking			
05	EIA0805	C	±0.25	C2	±50	P	1/5	1003	100K				
06	EIA1206	D	±0.50			W	1/8	1004	1M				
13	EIA1210	F	±1.00			X	1/10	1005	10M				
10	EIA2010					Y	1/16						
12	EIA2512					Z	1/32						

### 0805~2512 4 digits marking for Example Marking

Resistance	100Ω	2.2KΩ	10KΩ	49.9KΩ	100KΩ	1MΩ
Marking	1000	2201	1002	4992	1003	1004

### 0603: 3 digits Marking E24 Nominal Table

E24 code	10	11	12	13	15	16	18	20	22	24	27	30	33	36	39	43	47	51	56	62	68	75	82	91
----------	----	----	----	----	----	----	----	----	----	----	----	----	----	----	----	----	----	----	----	----	----	----	----	----

- Example: 101=100Ω 102=1KΩ (1st and 2nd are E24 code and 3rd code is multiplier)
- Resistance tolerance 1% for 0603: 3 digits marking in E96 (E96 series except E24 series)
- Digits marking for Example: 13C=13K3Ω; 68B=4K99Ω; 68X=49.9Ω

### Marking Table E96 Nominal Table

code	02	03	04	06	07	08	09	10	11	13	14	15	16	17	19	20	21	22	23	24	25	26	27
E96	102	103	107	113	115	118	121	124	127	133	137	140	143	147	154	158	162	165	169	174	178	182	187
code	28	29	31	32	33	34	35	36	37	38	39	40	41	42	43	44	45	46	47	48	49	50	51
E96	191	196	205	210	215	221	226	232	237	243	249	255	261	267	274	280	287	294	301	309	316	324	332
code	52	53	54	55	56	57	58	59	60	61	62	63	64	65	66	67	68	69	70	71	72	73	74
E96	340	348	357	365	374	383	392	402	412	422	432	442	453	464	475	487	499	511	523	536	549	562	576
code	75	76	77	78	79	80	81	82	83	84	86	87	88	89	90	91	92	93	94	95	96		
E96	590	604	619	634	649	665	681	698	715	732	768	787	806	825	845	866	887	909	931	953	976		

### Multiplier E96 Marking

Code	A	B	C	D	E	F	X	Y
Multiplier	10 <sup>0</sup>	10 <sup>1</sup>	10 <sup>2</sup>	10 <sup>3</sup>	10 <sup>4</sup>	10 <sup>5</sup>	10 <sup>-1</sup>	10 <sup>-2</sup>

## ► General Information

### **Token Thin Film Chips Add Powerful New Options**

Token electronics provides the industry's most comprehensive range of precision thin film technologies for discrete, network, and integrated passive components used in instrumentation; automotive electronics; communications systems; and portable electronics applications. Ultra-reliable precision Nichrome resistive elements are available on ceramic or silicon substrates in a wide variety of surface mount resistors.

In response to market demands for increased precision and stability, Token has expanded range of nichrome thin-film chip resistors. Offering solutions to precision test and measurement and voltage regulation across industrial, military and medical monitoring equipment markets designed to offer superior humidity performance.

### **Token Thick Film Chips Cut the Cost of Precision Resistors**

Token electronics has developed an extensive range of thick film / thin film resistive technologies for electronic circuits in power supplies; test and measurement; industrial electronics; telecommunications; audio circuits; automotive control systems; lighting controls; medical electronics; industrial equipment; and control systems applications.

In addition to this, proven thick film technologies from Token electronics provide a large range of standard resistive low Ohmic current sense products for critical battery management, and line termination. The enhanced performance of the chips is made possible by the precise use of the best resistance inks and a closely controlled production process.

### **Token Chip Low Ohmic Resistors come in Smaller Sizes and Minimized Power Consumption**

Today's electronic devices are becoming smaller and smaller. As a result, designers are moving more towards surface mount components not only for new designs but also to design out large axial and other through-hole resistors.

In most cases this is a straight forward task as several resistor manufacturers offer chip resistors with performances to match axial parts. However in some cases, due to power rating or pulse withstanding requirements, this has been impossible. The requirement, in particular, for pulse withstand capability is growing due to the need to protect sensitive modern electronic systems. To meet this demand Token electronics have designed a Pulse Withstanding Chip Resistor (PWR Series).