

Version:
February 24, 2017



Dielectric resonator Series

Token Electronics Industry Co., Ltd.

Taiwan: No.137, Sec. 1, Zhongxing Rd., Wugu District,
New Taipei City, Taiwan, R.O.C. 24872
Tel: +886 2981 0109 Fax: +886 2988 7487

China: 12F, Zhong Xing Industry Bld., Chuang Ye Road,
Nan Shan District, Shen Zhen City,
Guang Dong, China 518054
Tel: +86 755 26055363; Fax: +86 755 26055365

[Web: www.token.com.tw](http://www.token.com.tw)

[Email: rfq@token.com.tw](mailto:rfq@token.com.tw)



Production Index

Dielectric resonator Series

Dielectric Technology vs. Saw Technology	1
Dielectric Technology vs. Saw Technology	1
Dielectric Terminology	2
Dielectric Terminology	2
Dielectric Filters (DF)	5
Product Introduction (DF-A)	5
Dimensions (DF-A)	6
Typical Specifications (DF-A)	6
Typical Characteristic (DF-A)	7
Order Codes (DF-A)	8
Product Introduction (DF-B)	9
Dimensions (DF-B)	10
Typical Specifications (DF-B)	10
Typical Characteristic (DF-B)	11
Order Codes (DF-B)	12
Product Introduction (DF-C/D)	13
Dimensions (DF-C/D)	14
Typical Specifications (DF-C/D)	14
Typical Characteristic (DF-C/D)	15
Order Codes (DF-C/D)	16
Product Introduction (DF)	17
Dimensions (DF)	18
Typical Specifications (DF)	18
Typical Characteristic (DF)	19
Order Codes (DF)	20
Product Introduction (BP-R)	21
Dimensions (BP-R)	22
Typical Specifications (BP-R)	22
Order Codes (BP-R)	23
Product Introduction (LJ)	24
Dimensions (LJ)	25
Typical Specifications (LJ)	25
Typical Characteristic (LJ)	26
Order Codes (LJ)	27
Product Introduction (BP-S)	28
Dimensions (BP-S)	29
Typical Specifications (BP-S)	30
Order Codes (BP-S)	31
General Information	32
Dielectric Patch Antenna (DA)	33
Product Introduction	33
Typical Specifications	34
Dimensions	35
Typical Characteristic	36
Order Codes	36
General Information	37



Dielectric Coaxial Resonators (DR)	38
Product Introduction	38
Dimensions	39
Available Range of TEM Mode	40
Order Codes	41
General Information.....	42
Dielectric Resonators & Materials (TE)	43
Product Introduction	43
Available Range by Every Material	44
Frequency Chart of Every Material	44
Application Notice.....	45
Order Codes	46
General Information.....	47



Dielectric Technology vs. Saw Technology

► Dielectric Technology vs. Saw Technology

Dielectric Technology vs. Saw Technology

Table 1: Performance Comparison		
Performance Comparison	Dielectric Filter (2GHz)	SAW Filter (2GHz)
Insertion Loss	Low (>1.8dB)	Medium (>2.5dB)
Fractional Band Width	Wide (<10%)	Medium (<3%)
Frequency Range	Wide (<10G)	Medium (<3G)
Spurious Response	Fair	Good
Handling Power	High (<200W)	Low (<0.3W)
IM (Inter-Modulation)	Excellent	Fair
Temperature Performance	Stable (0~5ppm)	Unstable (-20~-90ppm)
Impedance Matching	Good	Good
Design flexibility	Good	Fair
Size	Medium	Small
Weight	Medium	Light
Cost	Low	Medium

The technology comparison between dielectric filter and SAW filter is shown in Table 1. Items of comparison are electrical performances (insertion loss, fractional bandwidth, spurious response), handling power and intermodulation, size and weight, temperature stability, design flexibility, and cost (mass productivity).

SAW filter is superior in spurious response, size, weight, especially, but inferior in fractional bandwidth, frequency range and high handling power. On the other hand, dielectric filter is superior in insertion loss, fractional bandwidth, handling power, intermodulation and temperature performance, but inferior in spurious response, size, and weight. Those features are due to physical nature. As a result, each technology may be compensative with each other.

Commercially speaking, SAW is suitable for less than 1 GHz low power application, for example 900MHz band cellular handset filters. Dielectric filter is suitable for more than 2 GHz high power application, for example millimeter wave filter and cellular base station filter. But in overlapping region, for example 2GHz band handset filters, the method to gain the most practical and powerful solution must be combination and fusion of these technologies. Now what is required strongly for dielectric filter is the break through to the new technology suitable for combining with SAW technology.

As a candidate of novel dielectric technologies, planar filter utilizing thin film electrode is introduced. That may be coexisting and will be harmonized with SAW technology in the future. And dielectric technology will be growing up more than ever. Especially, for use of high power, wide band and high frequency operation, dielectric technology will be kept as the most powerful technology.

Dielectric Terminology

► Dielectric Terminology

Dielectric Terminology & Glossary

How Piezoceramic Element Works

When a piezoceramic element is stressed electrically by a voltage, its dimensions change. When it is stressed mechanically by a force, it generates an electric charge. If the electrodes are not short-circuited, a voltage associated with the charge appears.

Relationships between applied forces and the resultant responses depend upon:

1. the piezoelectric properties of the ceramic;
2. the size and shape of the piece;
3. The direction of the electrical and mechanical excitation.

A piezoceramic is therefore capable of acting as either a sensing or transmitting element, or both. Since piezoceramic elements are capable of generating very high voltages, they are compatible with today's generation of solid-state devices - rugged, compact, reliable, and efficient.

Coaxial Resonator

A component in which standing waves are established in a ceramic coaxial line, short- or open-circuited at the end, remote from the drive. These resonators can be either $1/4 \lambda$ wavelength or $1/2 \lambda$ wavelength type.

Dielectric Dissipation Factor ($\tan\delta$)

The dielectric dissipation factor (dielectric loss factor), $\tan\delta$, for a ceramic material is the tangent of the dielectric loss angle. $\tan\delta$ is determined by the ratio of effective conductance to effective susceptance in a parallel circuit, measured by using an impedance bridge. Values for $\tan\delta$ typically are determined at 1 kHz.

Dielectric Resonator (DR)

An non-metallized dielectric ceramic which functions similarly to a mechanical resonant cavity at microwave frequencies, but has a greatly reduced size because of its high dielectric constant.

Dielectric Constant (K)

The relative dielectric constant is the ratio of the permittivity of the material, ϵ , to the permittivity of free space, ϵ_0 , in the unconstrained condition, i.e., well below the mechanical resonance of the part.

Equation: $K = (\text{permittivity of material } \epsilon / \text{permittivity of free space } \epsilon_0)$

Global Positioning System (GPS)

A global navigation system based on 24 or more satellites orbiting the earth at an altitude of 12,000 statute miles and providing very precise, worldwide positioning and navigation information 24 hours a day, in any weather. Also called the NAVSTAR system.



Spurious Mode

Output from a dielectric resonator caused by a signal or signals having frequencies other than the resonant frequency desired. The presence of higher resonant modes close to the resonant frequency of the principle mode will interfere with filter or oscillator performance.

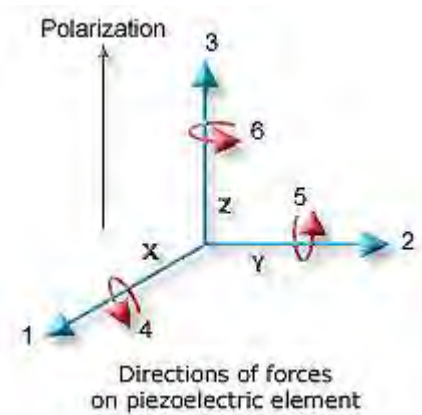

(Figure-1) - Directions of forces on piezoelectric element

Piezoelectric Charge Constant "d"

The piezoelectric constants relating the mechanical strain produced by an applied electric field are termed the strain constants, or the "d" coefficients. The units may then be expressed as meters per meter, per volts per meter (meters per volt). **Equation: $d = (\text{strain development} / \text{applied electric field})$**

It is useful to remember that large d_{ij} constants relate to large mechanical displacements which are usually sought in motional transducer devices. Conversely, the coefficient may be viewed as relating the charge collected on the electrodes, to the applied mechanical stress. d_{33} applies when the force is in the 3 direction (along the polarization axis) and is impressed on the same surface on which the charge is collected. d_{31} applies when the charge is collected on the same surface as before, but the force is applied at right angles to the polarization axis.

The subscripts in d_{15} indicate that the charge is collected on electrodes which are at right angles to the original poling electrodes and that the applied mechanical stress is shear. The units for the d_{ij} coefficients are commonly expressed as coulombs/square meter per newton/square meter.

Equation: $d = (\text{short circuit charge density} / \text{applied mechanical stress})$

When the force that is applied is distributed over an area which is fully covered by electrodes (even if that is only a portion of the total electrode) the units of the area cancel from the equation and the coefficient may be expressed in terms of change per unit force, coulombs per newton. To view the d_{ij} coefficients in this manner is useful when charge generators are contemplated, e.g., accelerometers.

Piezoelectric Voltage Constant "g"

The piezoelectric constants relating the electric field produced by a mechanical stress are termed the voltage constants, or the "g" coefficients. The units may then be expressed as volts/meter per newtons/square meter. **Equation: $g = (\text{open circuit electric field} / \text{applied mechanical stress})$**

Output voltage is obtained by multiplying the calculated electric field by the thickness of ceramic between electrodes. A "33" subscript indicates that the electric field and the mechanical stress are both along the polarization axis. A "31" subscript signifies that the pressure is applied at right angles to the polarization axis, but the voltage appears on the same electrodes as in the "33" case.

A "15" subscript implies that the applied stress is shear and that the resulting electric field is perpendicular to the polarization axis. High g_{ij} constants favor large voltage output, and are sought after for sensors. Although the g coefficient are called voltage coefficients, it is also correct to say the g_{ij} is the ratio of strain developed over the applied charge density with units of meters per meter over coulombs per square meter.

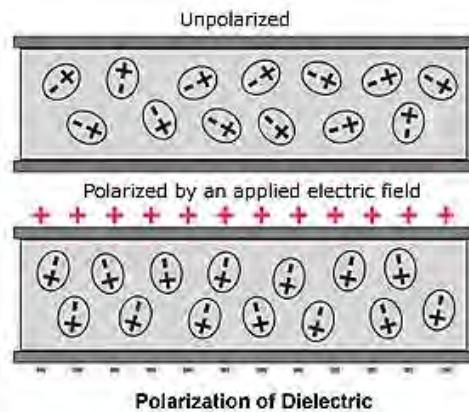

(Figure-2) - Polarization of Dielectric

Polarization of Dielectric

If a material contains polar molecules, they will generally be in random orientations when no electric field is applied. An applied electric field will polarize the material by orienting the dipole moments of polar molecules. This decreases the effective electric field between the plates and will increase the capacitance of the parallel plate structure. The dielectric must be a good electric insulator so as to minimize any DC leakage current through a capacitor.

Voltage Standing Wave Ratio (VSWR)

The traditional way to determine the reflection coefficient is to measure the standing wave caused by the superposition of the incident wave and the reflected wave. Traditionally the voltage is measured at a series of points using a slotted line. The ratio of the maximum divided by the minimum is the Voltage Standing Wave Ratio (VSWR). The VSWR is infinite for total reflections because the minimum voltage is zero. If no reflection occurs the VSWR is 1.0. VSWR and reflection coefficient are related as follows: **Equation: $VSWR = (1 + \rho) / (1 - \rho)$**

Quality Factor ($Q = 1 / \tan\delta$)

The figure of merit for assessing the performance or quality of a resonator, the Quality factor Q, is a measure of energy loss or dissipation per cycle as compared to the energy stored in the fields inside the resonator.

Dielectric Filters (DF)

► Product Introduction (DF-A)

||| Token Offers Dielectric RF Filters for Telecoms.

Features :

- Suitable for surface mount and reflow soldering.
- Excellent mechanical structure and temperature stability.
- Good selectivity, low insertion loss for using high Q-value resonators.

Token has extended the capabilities of its filter product line with the introduction of a new range of dielectric microwave filters to the available frequency range up to 5.8GHz. Token designs and manufactures custom electronic filters for defense, telecommunications and similar application increasing the range of products available to customers.

Two block-type dielectric RF filters for telecoms base station applications have been added to Token's DF range. The filters have been designed for cellular base station applications that use a digital pre-distortion amplifier (DPD), as they feature a wide pass band and flat ripple performance, which are required for DPD PA design.



Applications also include RF and microwave communications such as GSM, 3G, GPS, satellite and TV transmission, wireless security systems, radar, CT1, CT2, 900MHz, 1.8GHz, 2.4GHz, 5.8GHz Cordless Phone, wireless earphone, wireless microphone, aerospace and military.

The (DF-A) filter's small size (8.8 × 7.3 × 3.6 mm) means they require more less mounting space compared to Token's previous generation of filters for this application. The filters' highly sophisticated multi-pole design ensures high attenuation and good selectivity. Both the two members of the DF series have a ripple of 1.0 dB max.

In addition, Token enhances custom design capabilities for specialist applications. Our customers will benefit from the additional frequency ranges now available and from the excellent quality and lower costs achievable

Custom parts are available on request. Token will also produce devices outside these specifications to meet specific customer requirements, contact us with your specific needs. For more information, please link to Token official website "[Dielectric resonators](http://www.token.com.tw)".



► Dimensions (DF-A)

Dimensions (Unit: mm) (DF-A)

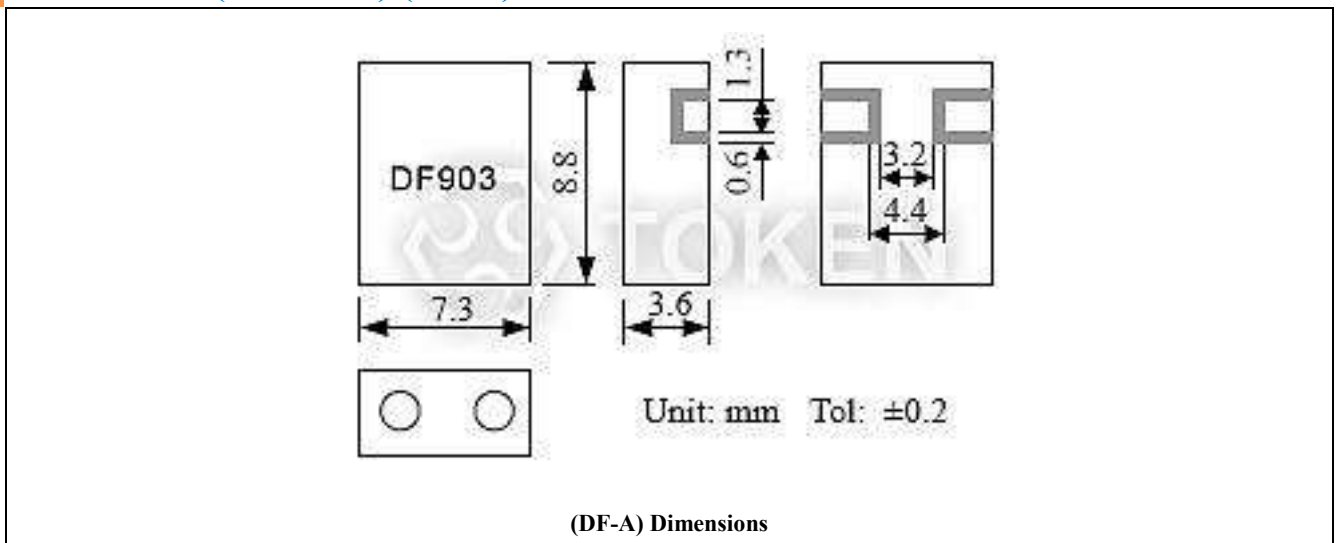

► Typical Specifications (DF-A)

Typical Specifications (DF-A)

Part No.	Center Frequency (MHz)	Band Width (MHz)	Insertion Loss (dB) max.	Ripple in Band Width (dB) max.	V.S.W.R max.	Attenuation (dB) min. (MHz)
DF457S30A	457	fo±15	3.0	1.0	2.0	17 at fo+50; 30 at fo-50
DF522S10A	522	fo±5	3.0	0.5	1.6	23 at fo+40; 40 at fo-40
DF683S30A	683	fo±15	2.5	1.0	2.0	20 at fo+64; 30 at fo-64
DF740S30A	740	fo±15	2.0	0.5	1.8	14 at fo+64; 20 at fo-64
DF864S10A	864	fo±5	2.5	0.5	1.5	15 at fo+24; 17 at fo-24
DF915S25A	915	fo±12.5	2.0	1.0	2.0	20 at fo+100; 35 at fo-100
DF903S6A	903	fo±3	3.5	0.5	1.5	32 at fo+24
DF927S6A	927	fo±3	3.5	0.5	1.5	32 at fo-24
DF1890S80A	1890	fo±40	1.5	1.0	2.0	15 at fo+200; 35 at fo-200
DF2403S20A	2403	fo±10	3.0	0.5	1.5	35 at fo+75
DF2475S20A	2475	fo±10	3.0	0.5	1.5	35 at fo-75

Typical Characteristic (DF-A)

Typical Characteristic (DF-A)

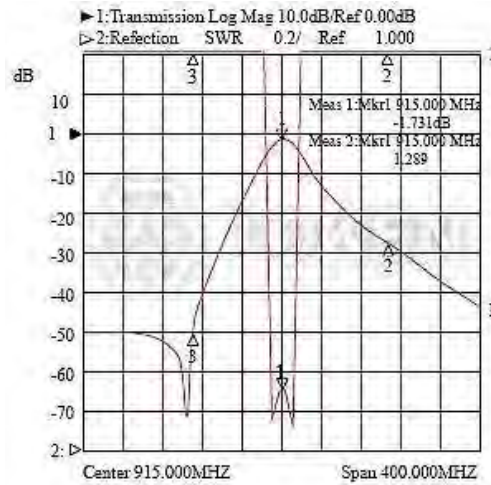

(DF-A) Type I Typical Characteristic
(Center 915.000MHz Span 400.000MHz)

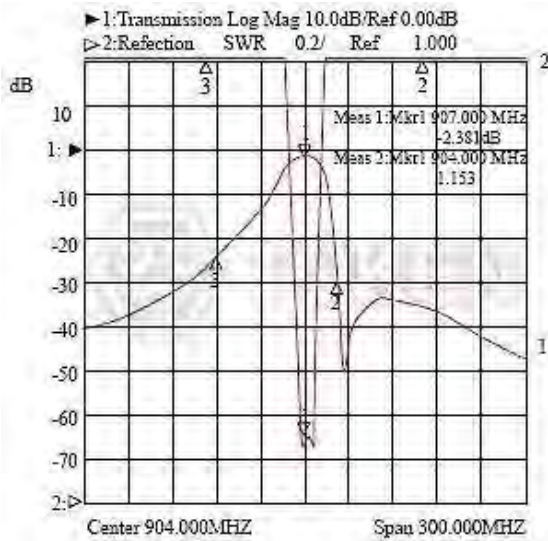

(DF-A) Type II Typical Characteristic
(Center 904.000MHz Span 300.000MHz)

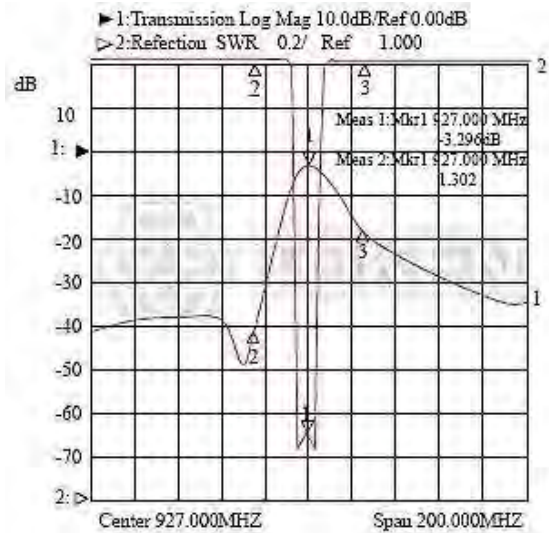

(DF-A) Type III Typical Characteristic
(Center 927.000MHz Span 200.000MHz)

▶ Order Codes (DF-A)

Order Codes (DF-A)

DF	864	S	10	A	
Part Number	Center Frequency	Connect Type	Bandwidth	Size	
		S		A	7.3 × 3.6 mm
		SMD type		B	6.0 × 3.0 mm
				C	4.5 × 2.0 mm
				D	3.6 × 1.8 mm

▶ Product Introduction (DF-B)

Token Dielectric Filter (DF-B) has a Ripple in Band Width (dB) 0.5 max.

Token (DF-B) filter manufactures with a fine-grained, high density, high purity dielectric material to keep the best performance with a ripple in band width (dB) 0.5 max.



The (DF-B) filter's small size (8.5 × 6.0 × 3.0 mm) means they require more less mounting space.

Available Center Frequency 650 MHz to 916 MHz with V.S.W.R 1.5 max., insertion loss 2.0 ~ 5.0 (dB) max.

RF dielectric filters are mounted in a surface mount package which assures mechanical stability and excellent lead planarity. RF filters can be customized designs and tighter tolerances available on request.

Products conform to the RoHS directive. Application of specific designs also available including different Dielectric values and Q specifications adjusted to frequency requirements.

Contact us with your specific needs. For more information, please link to Token official website "[Dielectric resonators](http://www.token.com.tw)".

► Dimensions (DF-B)

Filters (DF-B) Dimensions (Unit: mm)

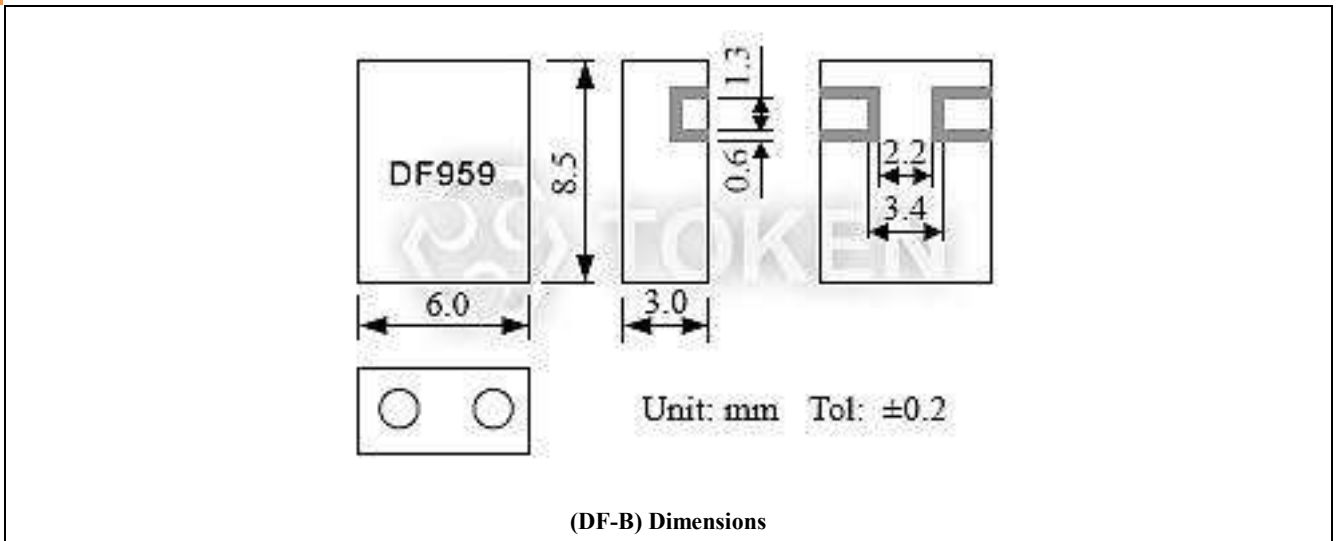

► Typical Specifications (DF-B)

Typical Specifications (DF-B)

Part No.	Center Frequency (MHz)	Band Width (MHz)	Insertion Loss (dB) max.	Ripple in Band Width (dB) max.	V.S.W.R max.	Attenuation (dB) min. (MHz)
DF650S30B	650	fo±15	2.5	0.5	1.5	19 at fo±64
DF700S20B	700	fo±10	2.5	0.5	1.5	19 at fo±64
DF710S08B	710	fo±4	5.0	0.5	1.5	35 at fo+100; 28 at fo+50
DF746S20B	746	fo±10	2.5	0.5	1.5	12 at fo-20
DF758S16B	758	fo±8	2.5	0.5	1.5	19 at fo±64
DF794S20B	794	fo±10	2.5	0.5	1.5	19 at fo±64
DF800S08B	800	fo±4	5.0	0.5	1.5	35 at fo+100; 28 at fo+50
DF836S20B	836	fo±10	2.5	0.5	1.5	19 at fo+52
DF850S08B	850	fo±4	5.0	0.5	1.5	30 at fo+100; 40 at fo-200
DF863S22B	863	fo±11	2.0	0.5	1.5	50 at fo-90; 20 at fo+90
DF875S24B	875	fo±12	2.3	0.5	1.5	30 at fo-70
DF903S09B	903	fo±4.5	3.5	0.5	1.5	34 at fo-64; 41 at fo+64
DF906S20B	906	fo±10	2.5	0.5	1.5	19 at fo±64
DF916S30B	916	fo±15	2.7	0.5	1.5	20.5 at fo±70

▶ Typical Characteristic (DF-B)

Typical Characteristic (DF-B)

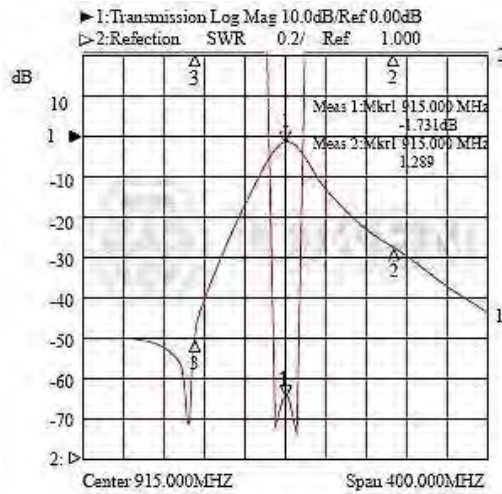

(DF-B) Type I Typical Characteristic
(Center 915.000MHz Span 400.000MHz)

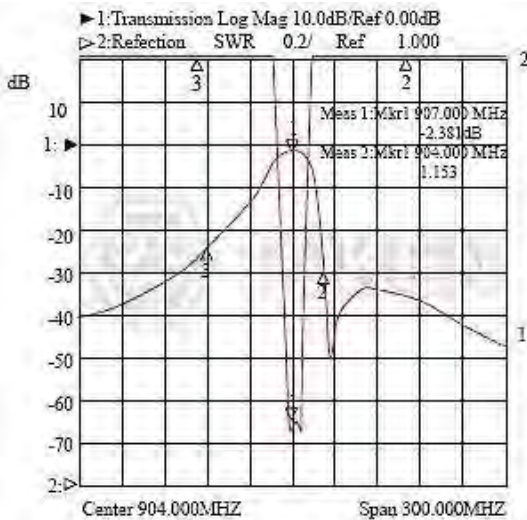

(DF-B) Type II Typical Characteristic
(Center 904.000MHz Span 300.000MHz)

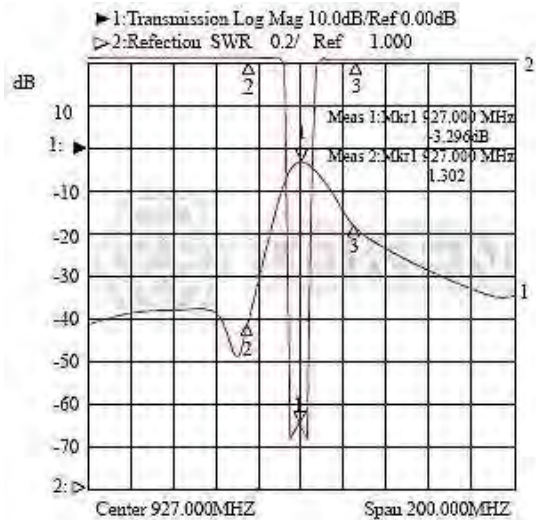

(DF-B) Type III Typical Characteristic
(Center 927.000MHz Span 200.000MHz)

▶ Order Codes (DF-B)

Order Codes (DF-B)

DF	836	S	20	B	
Part Number	Center Frequency	Connect Type	Bandwidth	Size	
		S		A	7.3 × 3.6 mm
				B	6.0 × 3.0 mm
				C	4.5 × 2.0 mm
				D	3.6 × 1.8 mm



▶ Product Introduction (DF-C/D)

Token Two Block-Type Dielectric Filters (DF-C/D) range up to 5.8GHz.

Token two block-type dielectric RF filters have been designed for cellular base station applications that use a digital pre-distortion amplifier (DPD), as they feature a wide pass band and flat ripple performance, which are required for DPD PA design.



Applications also include RF and microwave communications such as satellite and TV transmission, wireless security systems, radar, GSM, 3G, GPS, CT1, CT2, 900MHz, 1.8GHz, 2.4GHz, 5.8GHz Cordless Phone, wireless earphone, wireless microphone, aerospace and military.

The (DF-C/D) filter's small size (4.5 × 4.5 × 2.0 mm) means they require more less mounting space with a ripple of 1.0 dB max and insertion loss 2.0 (dB) max. Center frequency range from 1575 MHz to 5800 MHz with V.S.W.R 2.0 max.

The surface mount RF Dielectric Filters (DF-C/D) conform to the RoHS directive and package is suitable for automatic pick and place equipment which assures mechanical stability and excellent lead planarity. Customed designs and tighter tolerances are available on request. Application of specific designs also available including different Dielectric values and Q specifications adjusted to frequency requirements.

Contact us with your specific needs. For more information, please link to Token official website "[Dielectric resonators](http://www.token.com.tw)".

► Dimensions (DF-C/D)

Dimensions (Unit: mm) (DF-C/D)

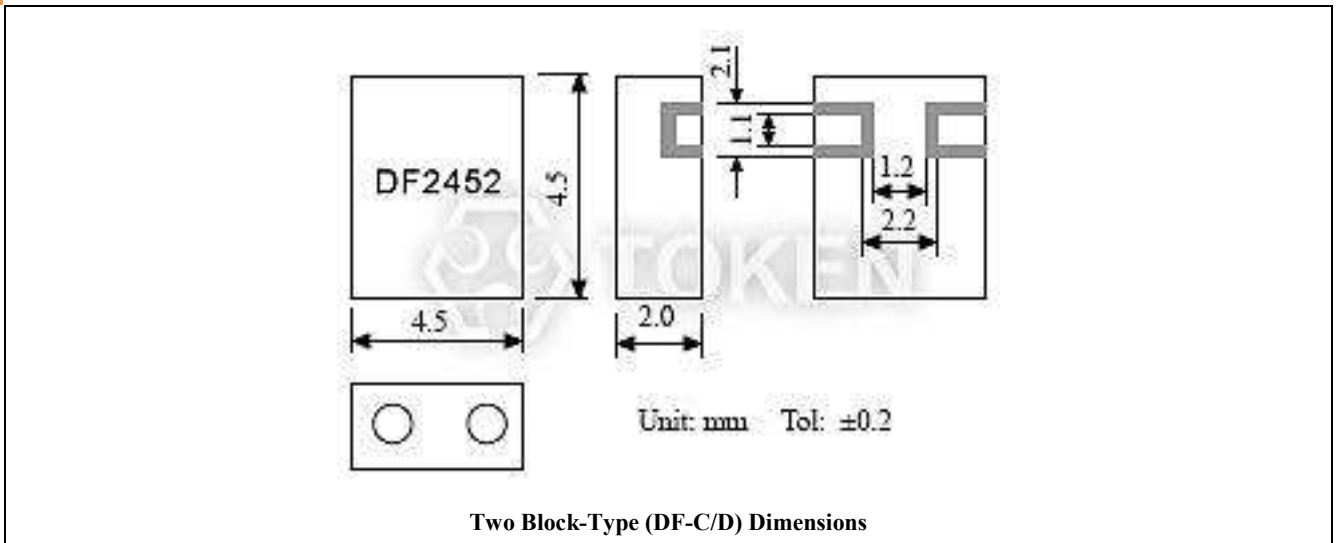

► Typical Specifications (DF-C/D)

Typical Specifications (DF-C/D)

Part No.	Center Frequency (MHz)	Band Width (MHz)	Insertion Loss (dB) max.	Ripple in Band Width (dB) max.	V.S.W.R max.	Attenuation (dB) min. (MHz)
DF1575S40C	1575	fo±20	2.0	0.7	2.0	20 at fo-100; 18 at fo+100
DF1855S70C	1855	fo±35	2.0	0.7	2.0	20 at fo+300; 20 at fo-300
DF1890S80C	1890	fo±40	2.0	0.7	2.0	15 at fo+250; 35 at fo-250
DF1950S90C	1950	fo±45	3.0	0.7	2.0	45 at fo+975; 45 at fo-975
DF2332S100C	2332	fo±50	2.5	0.7	2.0	25 at fo+500; 40 at fo-500
DF2450S100C	2450	fo±50	2.0	0.7	2.0	12 at fo+250; 15 at fo-250
DF3066S170D	3066	fo±85	2.0	1.0	2.0	10 at fo+300; 15 at fo-300
DF3480S120D	3480	fo±60	2.0	1.0	2.0	10 at fo+500; 20 at fo-500
DF3650S150D	3650	fo±75	2.0	1.0	2.0	15 at fo+750; 25 at fo-750
DF4880S160D	4880	fo±80	2.0	1.0	2.0	5 at fo+350; 15 at fo-350
DF5800S200D	5800	fo±100	2.0	1.0	2.0	5 at fo+400; 15 at fo-400

Typical Characteristic (DF-C/D)

Typical Characteristic (DF-C/D)

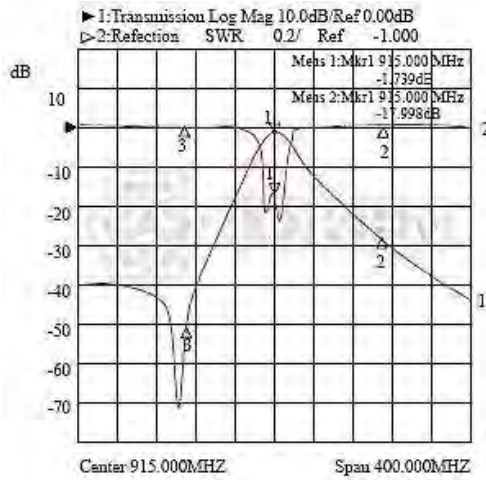

(DF-C/D) Type I Typical Characteristic
Center 915.000MHz (-1.739dB) & (-17.998dB) Span 400.000MHz

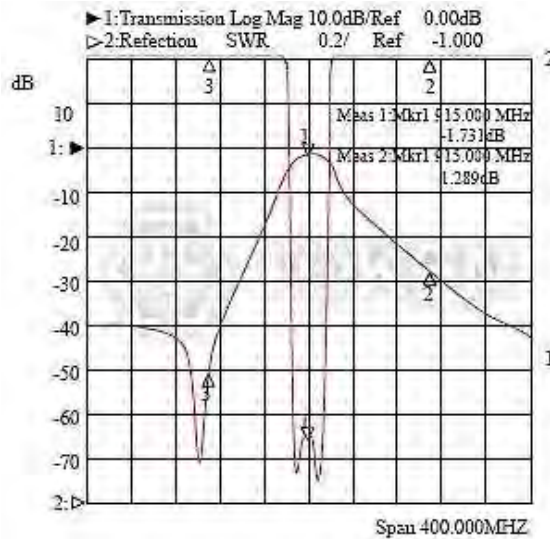

(DF-C/D) Type II Typical Characteristic
Center 904.000MHz (-1.731dB) & (1.289dB) Span 300.000MHz

▶ Order Codes (DF-C/D)

Order Codes (DF-C/D) For 2 Pole

DF	1950	S	90	C
Part Number	Center Frequency	Connect Type	Bandwidth	Size
		S	SMD type	A
				B
				C
				D

▶ Product Introduction (DF)

||| Dielectric Filters (DF) 3 or multi-pole range up to 5.8GHz.

Features :

- MBP 42R Series.
- Murata DFC Series Compatible.
- Application for CT1, CT2, 900MH, 1.8GHz, 2.4G WLL Cordless phone.

The dielectric technology based on ceramic material of high Dielectric Constant (K) has been contributing great size reduction of mobile telecommunication equipment, especially cellular handset and base station. That is superior in electrical performances and reliability. Furthermore it has good mass productivity and low cost.



Token (DF) filters' highly sophisticated multi-pole design ensures high attenuation and good selectivity. The (DF) multi-pole series filter's small size (8.6 × 9.0 × 3.0 mm) means they require more less mounting space with a ripple of 1.0 dB max. Insertion loss is from 2.0 ~ 3.5 (dB) max. Center frequency range from 860 MHz to 5800 MHz with V.S.W.R 2.0 max.

Coaxial dielectric filter is the most popular and commercially successful technology. Token takes this advance technology to manufacture coaxial type duplexer. This features high unloaded Q, excellent high power performance, flexible design capability, size reduction, low profile, and lighter weight.

Surface mount multi-pole (DF) series RF filter package is suitable for automatic pick and place equipment which assures mechanical stability and excellent lead planarity. Custom designs and tighter tolerances are available on request. Products conform to the RoHS directive.

Token will also produce devices outside these specifications to meet specific customer requirements, contact us with your specific needs. For more information, please link to Token official website "[Dielectric resonators](http://www.token.com.tw)".

► Dimensions (DF)

Dimensions (Unit: mm) (DF)

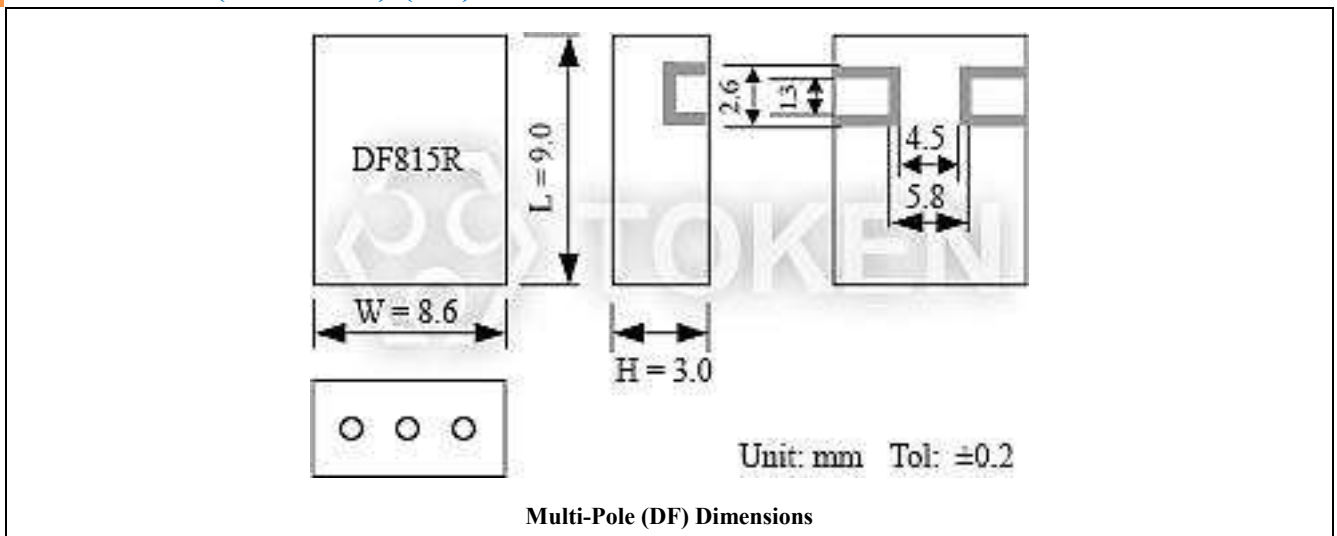

► Typical Specifications (DF)

Typical Specifications (DF)

Part No.	Center Frequency (MHz)	Bandwidth (MHz)	Insertion Loss (dB) max.	Ripple in Bandwidth (dB) max.	V.S.W.R max.	Attenuation (dB)min.(MHz)
DF43R860S20A	860	fo±10	3.0	0.8	2.0	-25 at fo+30; -22 at fo-30
DF43R1855S10A	1855	fo±5	3.5	1.0	2.0	-30 at fo+100; -28 at fo-100
DF43R950S20A	950	fo±10	3.5	0.8	2.0	-40 at fo+30; -35 at fo-30
DF44R3120S60A	3120	fo±30	3.0	1.0	1.5	-58 at fo+355; -55 at fo-375
DF45R1120S40A	1120	fo±20	2.5	1.0	2.0	-50 at fo+50; -50 at fo-50
DF33R815S20B	815	fo±10	2.5	0.8	2.0	-18 at fo+40; -25 at fo-40
DF33R1880S50B	1880	fo±25	3.5	1.0	2.0	-40 at fo+150; -40 at fo-150
DF23R1480S40C	1480	fo±20	2.5	1.0	2.0	-20 at fo+150; -20 at fo-150
DF23R1960S60C	1960	fo±30	2.0	1.0	2.0	-20 at fo+200; -20 at fo-200
DF23R2480S30C	2480	fo±15	2.5	1.0	2.0	-20 at fo+250; -20 at fo-250
DF23R5800S200D	5800	fo±100	2.0	1.0	2.0	-5 at fo+400; -15 at fo-400

▶ Typical Characteristic (DF)

Typical Characteristic (DF)

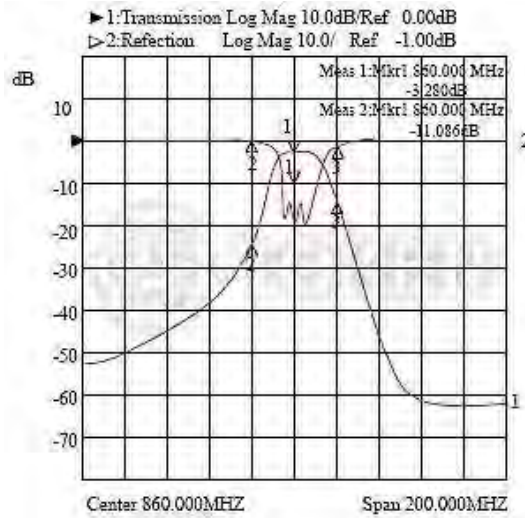

(DF) Type I Typical Characteristic
Center 860.000MHz (-3.280dB) & (-11.086dB) Span 200.000MHz

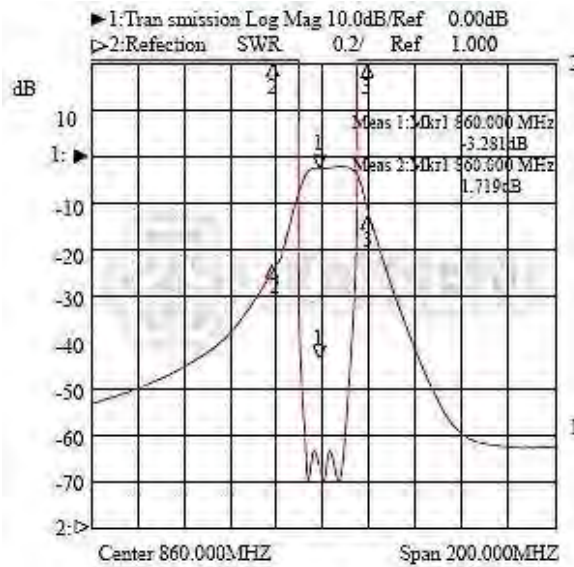

(DF) Type II Typical Characteristic
Center 860.000MHz (-3.281dB) & (1.719dB) Span 200.000MHz

Order Codes (DF)

Order Codes (DF)

DF	3	3R	815	S	20	B
Part Number	Thickness	Number of Resonator	Center Frequency (MHz)	Connect Type	BandWidth (MHz)	Size (W×H) (mm)
	4 3.8mm			S SMD type		A 11.8 × 3.8
	3 3.0mm					B 8.6 × 3.0
	2 2.0mm					C 5.8 × 2.0

▶ Product Introduction (BP-R)

Dielectric Band pass Filters (BP-R) Have a Low Ripple In Bandwidth 0.5 (dB) Max.

Features :

- Low insertion loss.
- Size small and light.
- High frequency selectivity.
- Temperature compensated.

Applications :

- Trunked radio system.
- Cellular, cordless phone.
- Military affairs, Base station.

Dielectric band pass filter, known as ceramic band pass filter, dielectric ceramic filter, or microwave ceramic filter in standard resonator sizes. Token (BP-R) series center frequency range is from 915 MHz to 1220 MHz basic rules of ceramic band-pass filters and diplexer. Insertion loss is from 2.0 ~ 3.5 (dB) max and a ripple in bandwidth 0.5 (dB) max.



The higher the Q-factor of a resonators/band pass filters, the better electrical performance for insertion loss. The more dielectric resonators combined together for a band pass ceramic filters, the better rejection, attenuation, and stop band will be. Determinant factor for Insertion Loss Q factor of a resonator, the bandwidth of a filter, and the number of resonators Determinant factor for Attenuation/rejection the number of resonators, connection type of resonators.

Token (BP-R) RF filters can be customized designs and tighter tolerances available on request. Token (BP-R) series are primarily designed for high dielectric constant lines and conform to the RoHS directive.

The (BP-R) series feature with high permittivity, high dielectric constants, extremely temperature stability and high Q that enables the design of stable microwave oscillators and filters. High dielectric constant (K) materials and associated products are also available for custom application requirements.

Contact us with your specific needs. For more information, please link to Token official website "[Dielectric resonators](#)".



► Dimensions (BP-R)

Dimensions (Unit: mm) (BP-R)

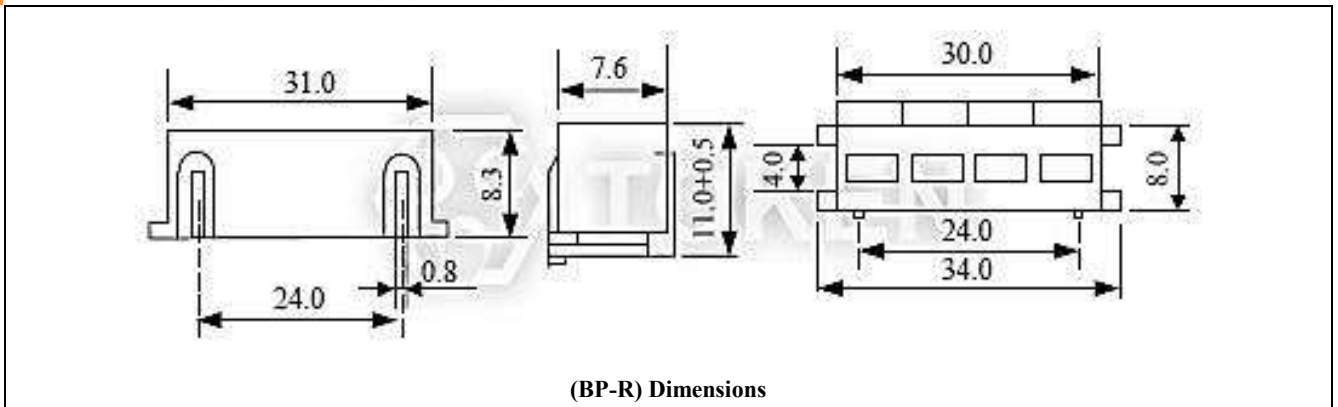

► Typical Specifications (BP-R)

Typical Specifications (BP-R)

Part No.	Center Frequency (MHz)	Band Width (MHz)	Insertion Loss (dB)max.	Ripple in Bandwidth (dB)max.	V.S.W.R max.	Attenuation (dB)min.(MHz)
BP63R915-01	915	fo±5	2.5	0.5	1.5	45 at fo±100
BP64R881-02	881	fo±10	2.0	0.5	2.0	60 at fo±100
BP84R650-01	650	fo±5	2.5	0.5	1.5	70 at fo±55
BP84R1200-03	1200	fo±15	2.0	0.5	2.0	70 at fo±60
BP74R959-02	959	fo±10	2.0	0.5	2.0	70 at fo±80
BP75R836-01	836	fo±5	3.5	0.5	1.5	80 at fo±50
BP76R1220-02	1220	fo±10	2.5	0.5	2.0	80 at fo±50

▶ Order Codes (BP-R)

Order Codes (BP-R)

BP	3	4R	1765	-	01
Part Number	Thickness	Number of Resonator	Center Frequency (MHz)	Bandwidth	
				01	10MHz
				02	20MHz
				03	30MHz

► Product Introduction (LJ)

||| Low Insertion Loss Type Dielectric Filters (LJ) Series.

Features :

- Low insertion loss.
- Temperature compensated.
- High frequency selectivity.
- small and lightweight.

Applications :

- Base station.
- Military affairs.
- Trunked radio system.
- Cellular, Cordless phone.

Token electronics manufacturing microwave dielectric filters, multi-layer filters, cavity filters, band-pass filter, military filters, high-frequency filters and so on, using high dielectric coefficient material and dielectric ceramics to meet specific design requirements, in line with RoHS standard.

Surface mount dielectric RF filters are mounted in a through hole package which assures mechanical stability and excellent lead planarity. Dielectric RF filters can be customized designs and tighter tolerances available on request. Products conform to the RoHS directive and Lead-free.

LJ Series with a stable temperature coefficient, small size, high stability, low insertion loss, good weld ability. Dielectric band-pass filters for use in microwave communications, data transmission, radar, and electronic warfare, military, aerospace and other fields.

Contact us with your specific needs. For more information, please link to Token official website "[Dielectric resonators](http://www.token.com.tw)".



► Dimensions (LJ)

Dimensions (Unit: mm) (LJ)

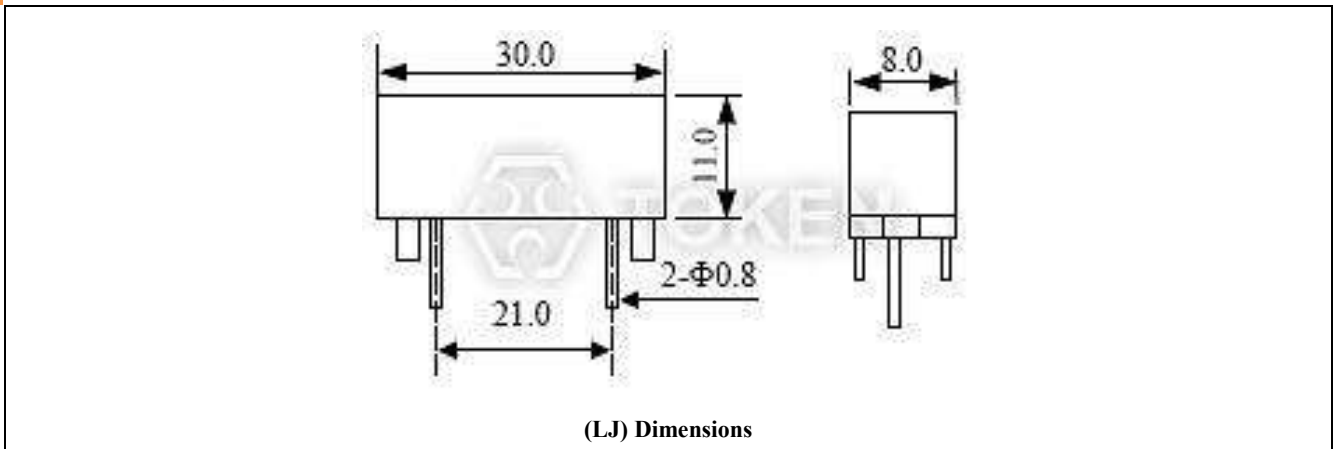

► Typical Specifications (LJ)

Typical Specifications (LJ)

Part No.	Center Frequency (MHz)	Band Width (MHz)	Insertion Loss (dB)max.	Ripple in BandWidth (dB)max.	V.S.W.R max.	Attenuation (dB)min.(MHz)
LJ900-C-A	900	fo±10	2.5	0.5	1.5	50 at fo±100
LJ1200-C-B	1200	fo±15	2.0	0.8	2.0	50 at fo±110
LJ950-D-B	950	fo±10	2.5	0.5	1.5	60 at fo±100
LJ1250-D-B	1250	fo±15	2.0	0.8	2.0	60 at fo±110

▶ Typical Characteristic (LJ)

Typical Characteristic (LJ)

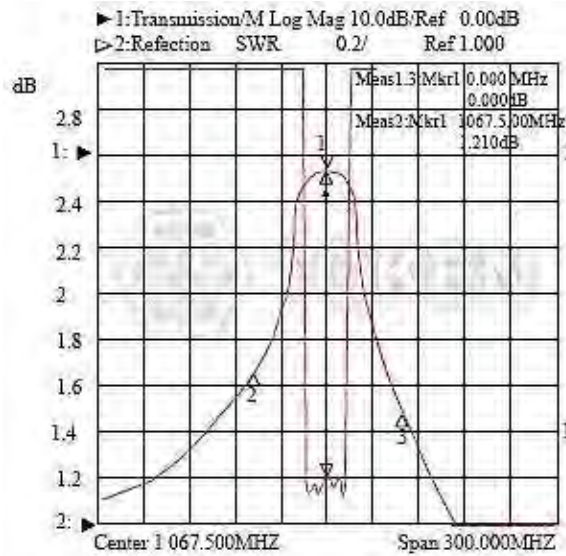

(LJ) Series I Typical Characteristic
Center 1067.500MHz (0.000dB) & (1.210dB) Span 300.000MHz

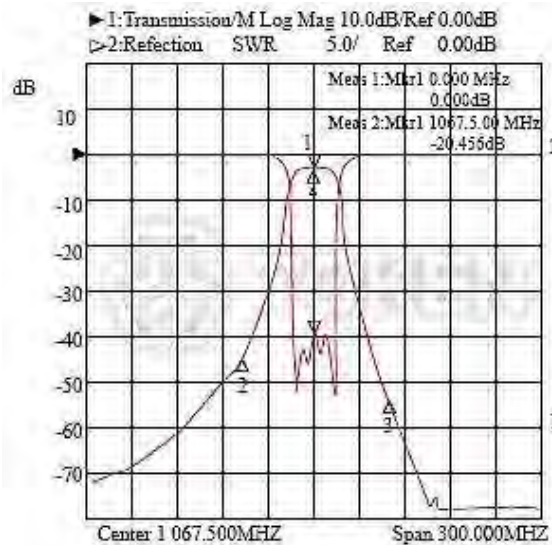

(LJ) Series II Typical Characteristic
Center 1067.500MHz (0.000dB) & (-20.456dB) Span 300.000MHz

Order Codes (LJ)

Order Codes (LJ)

LJ	900	-	C	-	A
Part Number	Center Frequency (MHz)		Number of Resonator		bandwidth
			C	3	A 10MHz
			D	4	B 20MHz

▶ Product Introduction (BP-S)

Token Dielectric Band pass Filters (BP-S) for high performance microwave filters and oscillators.

Features :

- Low insertion loss.
- High frequency selectivity.
- Temperature compensated.
- SMD Package, small and light.

Applications :

- Base station.
- Military affairs.
- Trunked radio system.
- Cellular, Cordless phone.

(BP-S) series with a high dielectric constant is the best microwave filters and oscillators.

Token Ceramic Dielectric material has a high dielectric constant and high Q values, and high temperature stability, especially for the design and stability of the microwave oscillations and filtering. German bond ceramic media for CT1, CT2, 900MHz, 1.8GHz, 2.4GHz, 5.8GHz cordless phones, wireless headsets, wireless microphones.

Token electronics manufacturing microwave dielectric filters, multi-layer filters, cavity filters, band-pass filter, military filters, and high-frequency filters, using low insertion loss, high Q, high frequency selectivity, and microwave dielectric ceramics to meet specific design requirements. Comply with RoHS standards.

(BP-S) series of dielectric filters and stable temperature coefficient, small size and high stability, low insertion loss and good weld ability. Dielectric band-pass filters for use in microwave communications, data transmission, radar, and electronic warfare, military, aerospace and other fields.

Custom parts are available on request. Token will also produce devices outside these specifications to meet specific customer requirements, contact us with your specific needs. For more information, please link to Token official website "[Dielectric resonators](http://www.token.com.tw)".



► Dimensions (BP-S)

Dimensions (Unit: mm) (BP-S)

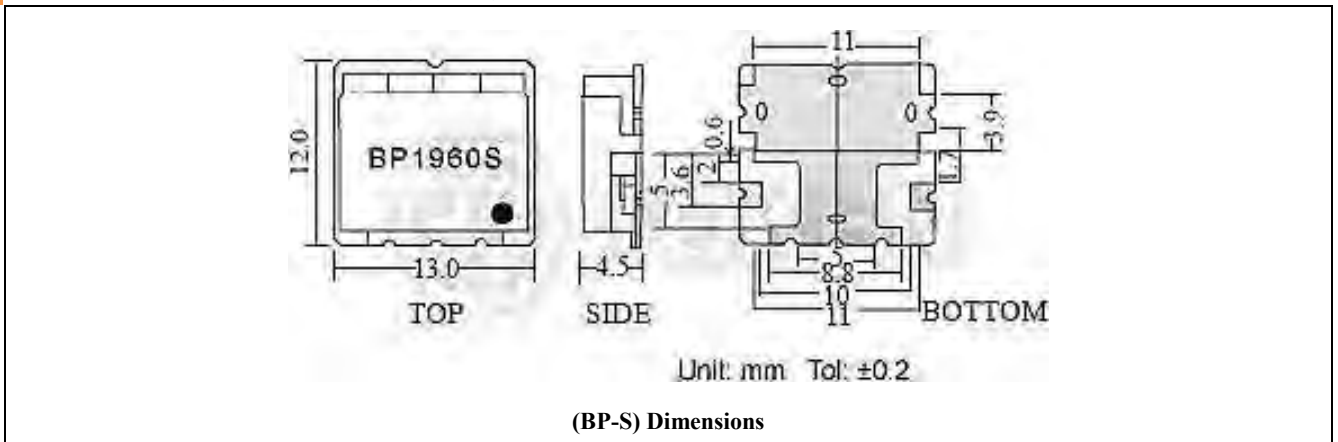

► Typical Specifications (BP-S)

Typical Specifications (BP-S)

Part No.	Center Frequency (MHz)	Band Width (MHz)	Insertion Loss (dB) max.	Ripple in bandwidth (dB) max.	V.S.W.R max.	Attenuation (dB)min.(MHz)
BP33R881S30A	881.5	fo±12.5	2.5	1.0	1.8	53 at fo±779
BP64R836S30A	836.5	fo±15	3.0	1.2	1.7	18 at fo±32.5
BP64R881S30A	881.5	fo±15	3.0	1.2	1.7	18 at fo ±32.5
BP34R1765S30A	1765	fo±15	3.5	1.0	1.8	30 at fo ±90
BP34R1855S30A	1855	fo±15	3.5	1.0	1.8	30 at fo ±90
BP55R1750S60A	1750	fo±30	3.0	1.5	1.7	30 at fo ±1810
BP55R1765S10A	1765	fo±5	5.0	1.0	1.8	20 at fo ±20
BP55R1765S30A	1765	fo±15	3.0	1.3	1.6	40 at fo ±80
BP55R1855S10A	1855	fo±5	5.0	1.0	1.8	20 at fo ±20
BP55R1855S30A	1855	fo±15	3.8	1.3	1.6	40 at fo ±80
BP66R1755S10A	1755	fo±5	10.0	1.0	2.0	22at fo ±1765
BP66R1845S10A	1845	fo±4.5	13.0	3.0	2.0	28 at fo ±1855
BP34R2315S30A	2315	fo±15	2.7	1.0	1.7	40 at fo ±160
BP34R2385S30A	2385	fo±15	2.7	1.0	1.7	40 at fo ±160
BP34R2442S80A	2442	fo±42	2.5	1.0	1.7	40 at fo ±160
BP64R409S10A	409.5	fo±3.5	3.0	0.8	1.7	30 at fo ±423
BP64R426S10A	426.5	fo±3.5	3.0	0.8	1.7	30 at fo ±413
BP66R1410S30A	1410	fo±14.5	3.0	1.0	1.5	18 at fo ±34.5
BP86R1474S10A	1474	fo±2.5	12.0	2.8	2.0	15 at fo ±10
BP34R1880S60A	1880	fo±32.5	2.5	1.0	1.5	18 at fo ±100
BP34R1960S60A	1960	fo±32.5	3.0	1.0	1.4	45 at fo ±130
BP34R1950S60A	1950	fo±30	3.0	1.0	1.8	38 at fo ±60
BP34R2140S60A	2140	fo±30	3.0	1.0	1.8	38 at fo ±60



▶ Order Codes (BP-S)

Order Codes (BP-S)

BP	3	4R	1765	S	30	A
Part Number	Thickness	Number of Resonator	Center Frequency (MHz)	Connect Type	Bandwidth	Version
				S	10	10MHz
				SMD type	30	30MHz
					60	60MHz

► General Information

Advantage of Token's Microwave Dielectric Components

New Microwave Dielectric Materials for Wireless Communication from Token Electronics

"Everything from the electromagnetic properties to microstructure of the material is important for the final result"

A small ceramic component made from a dielectric material is fundamental to the operation of filters and oscillators in several microwave systems, such as satellite TV receivers, military radar systems, Global Positioning System (GPS) devices, and mobile communications. Token Electronics had been able to develop specialized piezoelectric materials which lead to more reliable and clearer microwave communication signals.

In microwave communications, dielectric components are used to discriminate between wanted and unwanted signal frequencies in the transmitted and received signal. When the wanted frequency is extracted and detected it is necessary to maintain a strong signal nevertheless. For clarity it is also critical that the wanted signal frequencies are not affected by seasonal temperature changes.

The resonator materials for practical applications have to have certain key properties. A high relative dielectric constant is needed so that the materials can be miniaturized and a high quality factor (Q) is needed for improved selectivity. Low temperature variation of the material's resonant frequency is also required so that the microwave circuits remain stable.

Although large numbers of ceramic dielectric materials have been developed, it has proven difficult to satisfy all these requirements in a single material at a reasonable cost. "Token takes the advantages of these new materials that they are relatively cheap compared with some of the compounds currently used and in the future they can be improved even further by suitable additives and by optimizing the preparation conditions."

Dielectric Material Composition & Study

The new dielectric materials developed by Token, are based on ceramics formed by baking the pressed powdered starting material mixture in a furnace at between 1200 and 1550 degrees Celsius.

Token Engineers used X-ray diffraction studies, Raman spectroscopy and scanning electron microscopy to reveal the structure of the ceramics. The materials have the general formula $Ce(M_{1/2}Ti_{1/2})O_{3.5}$. Ce is the element cerium, Ti is titanium and O is oxygen. "M" represents any one of the metals magnesium, zinc, calcium, cobalt, manganese, nickel or tungsten. The numbers refer to the proportions of each element in the ceramic.

"Further work is in progress to find the exact composition, internal structure and secondary phases in the ceramics".

Token's Service & PDF Catalogue Download

Token reliably deliver high-quality microwave dielectric components according to the each customer special needs with respect to performance, costs, and technology modifications.

For marketing discontinuations or sourcing activities concerning dielectric products, you are encouraged to contact our Sales Department so the request can be properly directed within Token.



Dielectric Patch Antenna (DA)

► Product Introduction

Token (DA) Dielectric Patch Antenna Technology Makes The List.

Features :

- Small patch dimensions.
- Using high quality factor.
- Stabilized temperature coefficient.
- Provide highly stabilized performance.

Applications :

- Global Positioning Systems (GPS)
- GPS Hold, Car Navigation System, GPS PDA.
- W-LAN.

Dielectric antenna is fed using coaxial ceramic media. By a coaxial extension of the inner conductor to form an oscillator, used to excitation of electromagnetic waves, the sleeve of the role of the media, except clamping bar, the more important is the reflection of electromagnetic waves, thus ensuring the incentives from the coaxial line inner conductor of electromagnetic waves to the free end of dielectric rod transmission.

Token use of low-loss dielectric antennas, high-frequency dielectric material, strict process control, apply to the Global Positioning System (GPS), radio broadcast system of small antenna elements.

Token electronics manufacturing dielectric patch antenna with rectangular micro strip antenna design and offset one point feeding method for Global Positioning System GPS, media filters, multi-layer filters, cavity filters, band-pass filter, military filters, high-frequency filters and so on, in line with RoHS standards.

(DA) series of microwave antenna, which provides clients a custom design and deliver smaller tolerances. Dielectric antenna application specific design, but also for the frequency requirements, including different inductance values and Q specifications adjusted.

Token will also produce devices outside these specifications to meet specific customer requirements, contact us with your specific needs. For more information, please link to Token official website "[Dielectric resonators](#)".



Typical Specifications

Typical Specifications (DA)

Part Number	Size (mm)	Center Frequency (MHz)	Band width (MHz)	Gain (dBi)	Ground Plane (mm)	Application
DA1575S25T4A	25*25*4	1575	≥10	4.5	35*35	GPS
DA1575S25T4B	25*25*4	1575	≥10	4.5	70*70	
DA1575S25T2B	25*25*2	1575	≥10	4.5	70*70	
DA1580S25T4A	25*25*4	1580	≥15	4.5	35*35	
DA1580S25T4B	25*25*4	1580	≥15	4.5	70*70	
DA1580S25T2B	25*25*2	1580	≥15	4.5	70*70	
DA1580S18T4	18*18*4	1580	≥10	3.0	50*50	
DA1580S18T2	18*18*2	1580	≥10	3.0	50*50	
DA1580S13T4	13*13*4	1580	≥5	0.0	50*50	
DA2450S13T4	13*13*4	2450	≥5	0.0	50*50	
DA2450S13T2	13*13*2	2450	≥5	0.0	50*50	
DA1575S36T4	36*36*4	1575	≥30	5.0	80*80	
DA2450D16	Φ16	2450	45	2.1	50*70	
DA1616S25(Tx)	25*25*4	1616	≥10	4.0	70*70	Beidou Satellite Position System
DA2492S25(Rx)	25*25*4	2492	≥10	4.0	70*70	

● Note: Customer's specification, custom design, or ODM are welcomed on request.



Dimensions

Dimensions (DA)

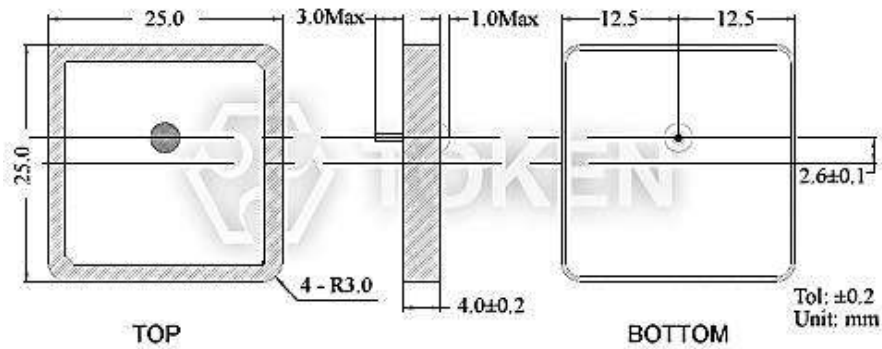

(DA) Dimensions I

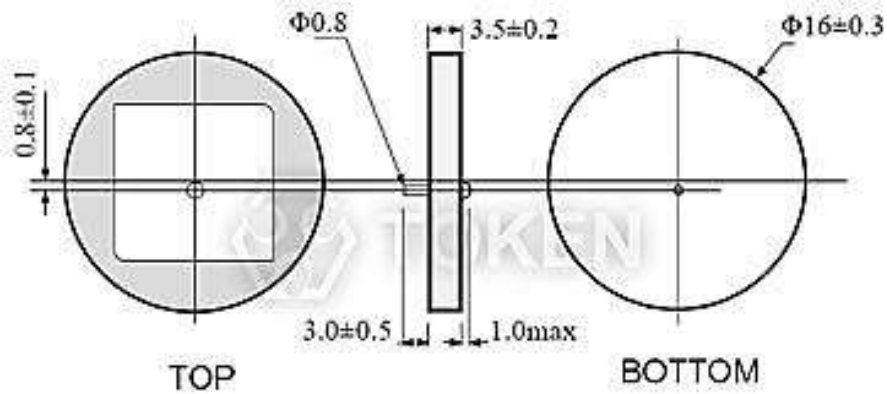

(DA) Dimensions II

Typical Characteristic

Typical Characteristic (DA)

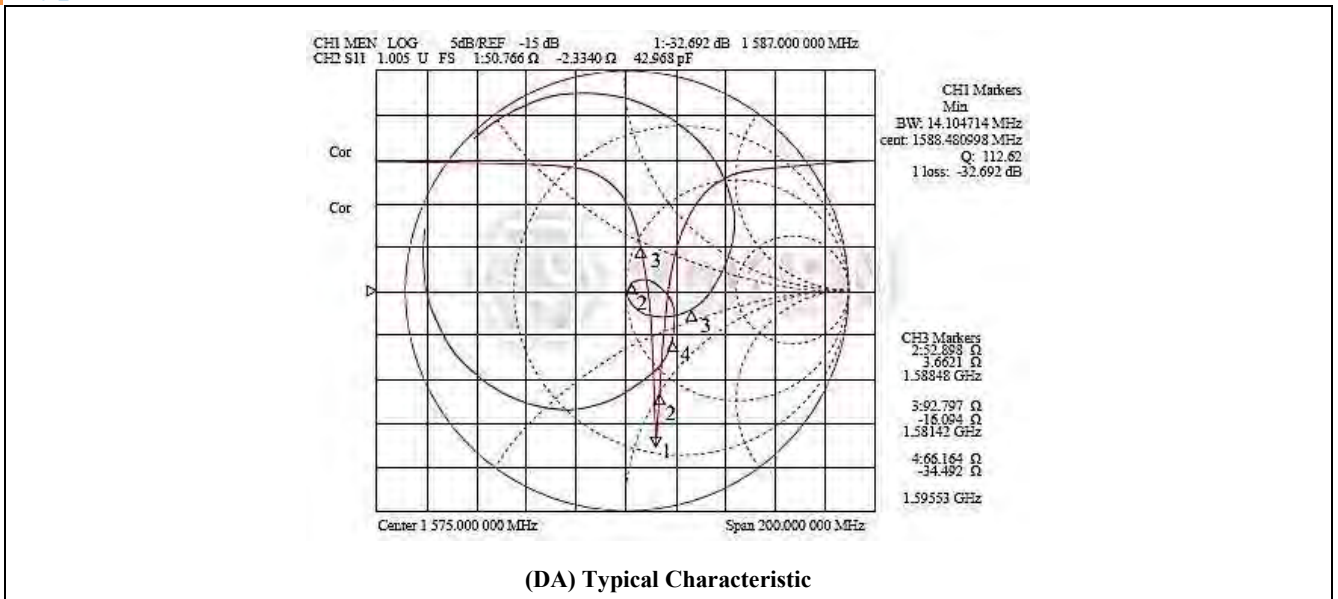

Order Codes

Order Codes (DA)

DA	1580	S	18	T2
Dielectric Patch Antenna	Center Frequency	Structure	Dimensions	Thickness

► General Information

Advantage of Token's Microwave Dielectric Components

New Microwave Dielectric Materials for Wireless Communication from Token Electronics

"Everything from the electromagnetic properties to microstructure of the material is important for the final result"

A small ceramic component made from a dielectric material is fundamental to the operation of filters and oscillators in several microwave systems, such as satellite TV receivers, military radar systems, Global Positioning System (GPS) devices, and mobile communications. Token Electronics had been able to develop specialized piezoelectric materials which lead to more reliable and clearer microwave communication signals.

In microwave communications, dielectric components are used to discriminate between wanted and unwanted signal frequencies in the transmitted and received signal. When the wanted frequency is extracted and detected it is necessary to maintain a strong signal nevertheless. For clarity it is also critical that the wanted signal frequencies are not affected by seasonal temperature changes.

The resonator materials for practical applications have to have certain key properties. A high relative dielectric constant is needed so that the materials can be miniaturized and a high quality factor (Q) is needed for improved selectivity. Low temperature variation of the material's resonant frequency is also required so that the microwave circuits remain stable.

Although large numbers of ceramic dielectric materials have been developed, it has proven difficult to satisfy all these requirements in a single material at a reasonable cost. "Token takes the advantages of these new materials that they are relatively cheap compared with some of the compounds currently used and in the future they can be improved even further by suitable additives and by optimizing the preparation conditions."

Dielectric Material Composition & Study

The new dielectric materials developed by Token, are based on ceramics formed by baking the pressed powdered starting material mixture in a furnace at between 1200 and 1550 degrees Celsius.

Token Engineers used X-ray diffraction studies, Raman spectroscopy and scanning electron microscopy to reveal the structure of the ceramics. The materials have the general formula $Ce(M_{1/2}Ti_{1/2})O_{3.5}$. Ce is the element cerium, Ti is titanium and O is oxygen. "M" represents any one of the metals magnesium, zinc, calcium, cobalt, manganese, nickel or tungsten. The numbers refer to the proportions of each element in the ceramic.

"Further work is in progress to find the exact composition, internal structure and secondary phases in the ceramics".

Token's Service & PDF Catalogue Download

Token reliably deliver high-quality microwave dielectric components according to the each customer special needs with respect to performance, costs, and technology modifications.

For marketing discontinuations or sourcing activities concerning dielectric products, you are encouraged to contact our Sales Department so the request can be properly directed within Token.



Dielectric Coaxial Resonators (DR)

► Product Introduction

Token coaxial resonators (DR) are the cornerstone of RF microwave communications.

Features :

- High quality factor.
- High dielectric constant.
- Low temperature coefficient.
- Wide range of resonant frequency.

Applications :

- CDMA/PCS/WLL/IMT2000.
- Filters, Duplexer, Oscillators (DRO/VCO).
- Wireless headphone, wireless security system.
- 900MHz, 1.8GHz, 2.4GHz, 5.8GHz wireless phone.

(DR) is a kind of microwave components, also known as ceramic resonator, Token electronics manufacturing dielectric resonator (cylindrical, ring), coaxial resonator (rectangular cavity, cylindrical cavity, coaxial cavity resonator), microwave resonator, etc. It is made high-Q dielectric ceramics; temperature coefficient is good, mainly used in microwave oscillators and filters.

Dielectric resonator size and dielectric material is inversely proportional to the square root of the dielectric constant, dielectric materials, dielectric constant the greater the required dielectric ceramic block the smaller, thus the smaller the resonator size. Another important parameter is the insertion loss, low dielectric loss microwave dielectric materials, dielectric filters that affect the insertion loss of a major factor. Microwave dielectric Q value and dielectric loss is inversely proportional to the relationship. Q value is greater the lower the filter insertion loss.

Therefore, the microwave dielectric ceramic materials of high dielectric constant is conducive to the miniaturization of microwave dielectric filters, can filter with the microwave tube, a microstrip line realization of microwave hybrid integrated circuit, so that the device dimensions to mm order of magnitude, the price is also much lower than the metallic cavity.

The (DR) impedance used in TEM mode is direct function of its dimensions and of the dielectric material permittivity. Token coaxial ceramic resonators provide the customers with high Q higher parallel resonant impedance and better temperature characteristics than inductor coils and associated lumped constant elements used in RF amplifiers and oscillators circuits. According to dielectric resonator frequency stabilization mechanism, using dielectric resonator stabilized FET oscillator frequency (also referred to DRO) can be classified into 4 types, namely, reflective, band-reject type, transmission type and feedback type.

(DR) series with two ports, depending on port different boundary conditions, in accordance with the basic structure of the resonator is divided into three types: half-wavelength type, quarter-wavelength type, and capacitive load type, each structure each with distinct characteristics. Token (DR) series features with small size, high temperature stability characteristics. Indirectly, (DR) series is suitable for a variety of microwave communications equipment, particularly suitable for PCS / PCN filters, base stations, radar detectors, satellite broadcast reception systems, military microwave facilities. Comply with RoHS standards.

Custom parts are available on request. Token will also produce devices outside these specifications to meet specific customer requirements, contact us with your specific needs. For more information, please link to Token official website "[Dielectric resonators](http://www.token.com.tw)".



► Dimensions

Dimensions (Unit: mm) (DR)

Part Number	W(O/D)	A(I/D)	B	C	T
DR120	12.0±0.2	① Φ4.0±0.2	without tab	3.2	1.0
		② Φ3.55±0.2	1.5		
DR100	10.0±0.2	① Φ3.3±0.2	1.3	3.0	1.0
DR80	8.0±0.2	① Φ2.7±0.2	1.3	2.6	0.7
DR60	6.0±0.2	① Φ2.5±0.2	without tab	2.4	0.7
		② Φ2.2±0.2	without tab		
		③ Φ2.0±0.2	1.2		
DR50	5.0±0.2	① Φ1.8±0.2	1.0	2.2	0.6
		② Φ1.5±0.2	1.0		
DR40	4.0±0.1	① Φ1.8±0.1	0.8	1.8	0.6
		② Φ1.5±0.1	without tab		
		③ Φ1.2±0.1	without tab		
DR30	3.0±0.1	① Φ1.0±0.1	0.7	1.5	0.5
DR20	2.1±0.1	① Φ0.6±0.1	0.5	1.2	0.5

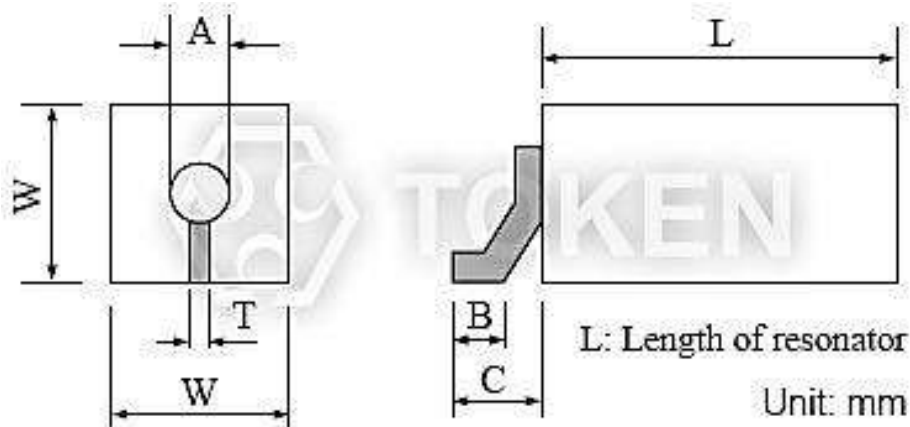

(DR) Dimensions

Available Range of TEM Mode

Available Range of TEM Mode (DR)

Material	Dielectric Constant	Tf ^[1]	Type	Characteristic Impedance (Ω)	Wave Length	Frequency Range (MHz)	Q ^[2] (min)
A Series	21±1	0±10	DR120	①15 ②17	λ/4	800~1300	800
					λ/2	1600~2700	1000
			DR100	16	λ/4	800~1300	700
					λ/2	1600~3200	800
			DR80	15	λ/4	1000~3200	650
					λ/2	2000~3000	700
			DR60	①12 ②14 ③15	λ/4	1000~2700	550
					λ/2	2000~3000	600
			DR50	①14 ②17	λ/4	1300~3000	450
					λ/2	2500~4000	500
DR40	①11 ②14 ③17	λ/4	1300~4000	380			
		λ/2	2500~4000	400			
DR30	15	λ/4	1900~4000	320			
		λ/4	2800~5000	250			
DR20	17	λ/4	2800~5000	250			
		λ/4	2800~5000	250			
B Series	36±1	0±10	DR120	①12 ②13	λ/4	600~1000	700
					λ/2	1200~2400	900
			DR100	12	λ/4	600~1200	600
					λ/2	1200~2400	800
			DR80	12	λ/4	800~1500	500
					λ/2	1600~3000	700
			DR60	①10 ②11 ③12	λ/4	800~1800	450
					λ/2	1600~3500	550
			DR50	①11 ②13	λ/4	800~1800	380
					λ/2	1600~3500	450
DR40	①9 ②11 ③13	λ/4	1000~2700	320			
		λ/2	2000~4800	400			
DR30	12	λ/4	1300~3000	220			
		λ/4	1300~3000	220			
DR20	13	λ/4	1300~3000	220			
		λ/4	1300~3000	220			
C Series	90±2	0±10	DR120	①7 ②8	λ/4	400~800	650
					λ/2	800~1500	700
			DR100	7	λ/4	600~800	550
					λ/2	1200~2400	650
			DR80	7	λ/4	440~1000	450
					λ/2	1000~1500	550
			DR60	①6 ②7 ③7	λ/4	440~1300	400
					λ/2	1000~2200	470
			DR50	①7 ②8	λ/4	500~1800	380
					λ/2	1000~3000	450
DR40	①6 ②7 ③8	λ/4	900~1600	200			
		λ/2	2000~4800	300			
DR30	7	λ/4	900~1600	250			
		λ/4	900~1600	250			
DR20	8	λ/4	900~1600	150			
		λ/4	900~1600	150			

- [1] Frequency stability of temperature.[2] Q value depends on lower limit of frequency range.



Order Codes

Order Codes (DR)

DR	30	A	1	W4	2533	T			
Dielectric Resonators Part Number	Dimension	Material	Impedance		Wave Length		Center Frequency (MHz)	Configuration	
			1	①	W2	$\lambda/2$		T	tab
			2	②	W4	$\lambda/4$		N	without tab
			3	③					

► General Information

Advantage of Token's Microwave Dielectric Components

New Microwave Dielectric Materials for Wireless Communication from Token Electronics

"Everything from the electromagnetic properties to microstructure of the material is important for the final result"

A small ceramic component made from a dielectric material is fundamental to the operation of filters and oscillators in several microwave systems, such as satellite TV receivers, military radar systems, Global Positioning System (GPS) devices, and mobile communications. Token Electronics had been able to develop specialized piezoelectric materials which lead to more reliable and clearer microwave communication signals.

In microwave communications, dielectric components are used to discriminate between wanted and unwanted signal frequencies in the transmitted and received signal. When the wanted frequency is extracted and detected it is necessary to maintain a strong signal nevertheless. For clarity it is also critical that the wanted signal frequencies are not affected by seasonal temperature changes.

The resonator materials for practical applications have to have certain key properties. A high relative dielectric constant is needed so that the materials can be miniaturized and a high quality factor (Q) is needed for improved selectivity. Low temperature variation of the material's resonant frequency is also required so that the microwave circuits remain stable.

Although large numbers of ceramic dielectric materials have been developed, it has proven difficult to satisfy all these requirements in a single material at a reasonable cost. "Token takes the advantages of these new materials that they are relatively cheap compared with some of the compounds currently used and in the future they can be improved even further by suitable additives and by optimizing the preparation conditions."

Dielectric Material Composition & Study

The new dielectric materials developed by Token, are based on ceramics formed by baking the pressed powdered starting material mixture in a furnace at between 1200 and 1550 degrees Celsius.

Token Engineers used X-ray diffraction studies, Raman spectroscopy and scanning electron microscopy to reveal the structure of the ceramics. The materials have the general formula $Ce(M_{1/2}Ti_{1/2})O_{3.5}$. Ce is the element cerium, Ti is titanium and O is oxygen. "M" represents any one of the metals magnesium, zinc, calcium, cobalt, manganese, nickel or tungsten. The numbers refer to the proportions of each element in the ceramic.

"Further work is in progress to find the exact composition, internal structure and secondary phases in the ceramics".

Token's Service & PDF Catalogue Download

Token reliably deliver high-quality microwave dielectric components according to the each customer special needs with respect to performance, costs, and technology modifications.

For marketing discontinuations or sourcing activities concerning dielectric products, you are encouraged to contact our Sales Department so the request can be properly directed within Token.



Dielectric Resonators & Materials

(TE)

► Product Introduction

Microwave dielectric resonator material is the cornerstone of future communications technology.

Features :

- High Q Value.
- Easy to control τ f.
- Various dielectric constant materials.

Applications :

- Police Radar Detectors.
- Dielectric Resonator Antennas.
- LMDS/MMDS Wireless Cable TV.
- Automobile Collision Avoidance Sensors.
- LNB, PCS/PCN Filters, Duplexer & Combiners.
- Cellular Base Station Filter, Duplexer & Combiners.

Microwave dielectric ceramics as the key basic materials to modern communication technology, after Token Electronics years of continuous research and development, using the latest technology to produce microwave ceramics have achieved a variety of dielectric constant, quality factor Q of the new media ceramic materials, and as a dielectric material application microwave frequencies of modern circuits, and modern electronic communications in the filters, resonators, dielectric substrates, such as microwave dielectric waveguide circuit components materials.



Comparing with microwave dielectric components made of Token's ceramic materials and metal cavity resonator, obviously, Token dielectric resonator features with a light weight, small volume, temperature coefficient of stability, cheap, and so on. They have been widely used in satellite broadcast reception systems, PCS / PCN filters, base stations, radar detectors, wireless mobile communications, telecommunications computer systems, military facilities, microwave, modern medicine and many other areas.

Taking advantage of Token's microwave dielectric ceramic materials for dielectric filters and resonators, with a relatively high dielectric constant, can make the device smaller, space-saving design of the circuit; high quality factor Q value and low dielectric loss, in order to ensure a good selection frequency characteristics and low insertion loss of the device; the temperature coefficient is small, in order to ensure the thermal stability of the device. Dielectric constant, quality factor Q, the temperature coefficient, these three parameters to evaluate the important microwave dielectric ceramic material specifications and production.

Custom parts are available on request. Token will also produce devices outside these specifications to meet specific customer requirements, contact us with your specific needs. For more information, please link to Token official website "[Dielectric Resonators](http://www.token.com.tw)".



▶ Available Range by Every Material

Available Range by Every Material TE01 δ Mode (TE)

Material Series	Dielectric Constant	Fo Q(1/tanδ)	Temperature Coefficient (PPM/°C)	Insulation Resistance (Ω-cm)	Application Frequency Range	Application Range
TE21	19~22	6,000@10GHz	0 ± 3	>10 ¹⁴	Refer Frequency Chat	Refer Frequency Chat
TE30	29~30	15,000@10GHz	0 ± 6	>10 ¹⁴		
TE36	35~37	10,000@4GHz	0 ± 3	>10 ¹⁴		
TE45	44~46	10,000@4GHz	0 ± 6	>10 ¹⁴		
TE80	79~81	7,000@1GHz	0 ± 6	>10 ¹⁴		
TE90	89~91	7,000@1GHz	0 ± 6	>10 ¹⁴		

▶ Frequency Chart of Every Material

Frequency Chart of Every Material TE01 δ Mode (TE)

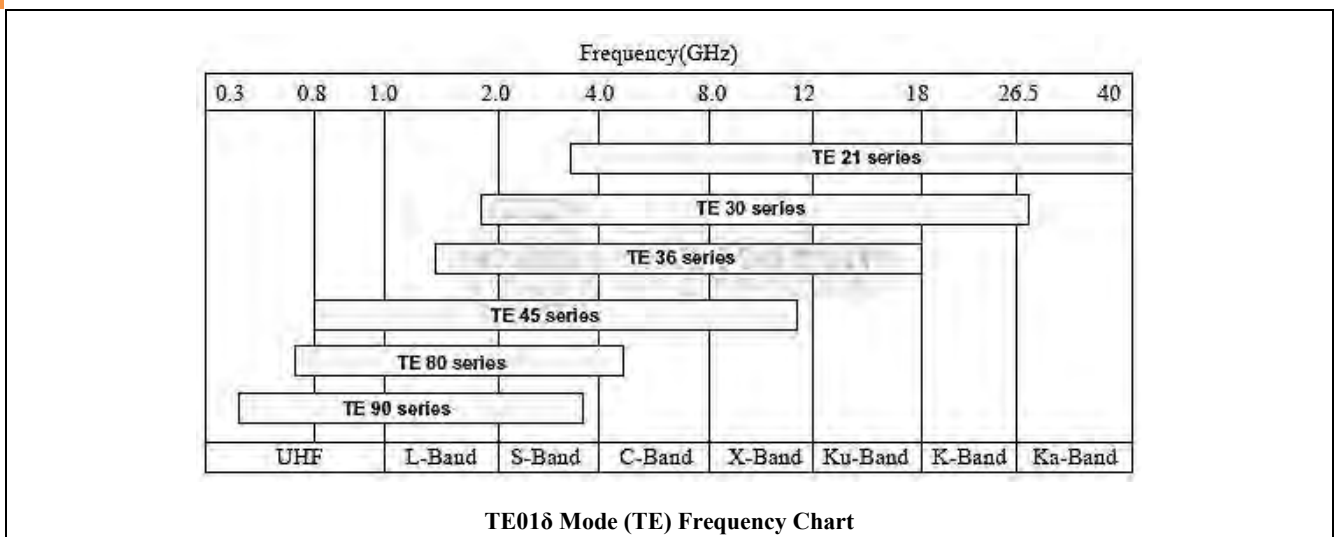

▶ Application Notice

Application Notice TE01 δ Mode (TE)

1. Aging:

Ceramics aging is small. Microwave Dielectric Ceramics any change in resonant frequency can be attributed to changes in measurement cavity or measurement techniques.

2. Water Absorbing:

Ceramics absorb water is not obvious, but the moisture condensation in the ceramic microwave resonator on the surface will affect the Q_u . But Q_u will be self-healing, when the water dried, For example, Dielectric resonator in the filter operation of the self-heating.

3. Cleanliness:

Q_u degradation of the oil may be due to a finger, pencil lead note, tape, adhesives, or other contaminants. Cleanliness of the dielectric ceramics is important.

4. Dielectric Constant:

In fact, the microwave dielectric ceramics of the dielectric constant is not fixed. It varies with the additives added, and used to determine the temperature coefficient ceramics. The dielectric constant of each batch is slightly different and it changes slightly with temperature changes. Token compensates for these effects and provide resonators size to frequency, and offers custom temperature coefficient on request.

5. Dielectric loss factor $\tan\delta$ & Q_u :

Dielectric loss factor and quality factor of the relationship, such as Quality Factor ($Q = 1 / \tan\delta$), Dielectric microwave materials are commonly assigned a loss tangent to permit an estimate of signal losses. Ceramic resonator is usually run on a specific frequency, a specific geometric shape, it can directly measure its size, with no-load quality factor Q_u , Q_u is an important basic resonator parameters (more useful than the loss tangent), particularly suitable filter and oscillator applications.

6. Smooth Surfaces:

Ceramic hard surface contact, it is prone to very small fragments. Most of the small fragments will not affect the electrical properties of dielectric ceramics. Ceramic surface roughness is not particularly important factor. Ceramic resonator itself does not current exist only in the form of stored energy from the field. Smooth surfaces are desirable from the standpoint of avoiding trapped contaminants.

7. Thermal Shock:

Microwave dielectric ceramics in the temperature exceeds 1200° in furnace to burn out; they can be more resistant than the temperature of electronic devices, far beyond the welding temperature. However, the thermal conduction velocity of dielectric ceramics is much slower than the metal. Large temperature gradient through the ceramic device, because of uneven expansion, could lead to device failure, which is called thermal shock. Suddenly applied heat in the thick ceramic devices will lead to broken ceramics.

8. Adhesives:

Adhesives to install ceramic resonators must be carefully selected. Adhesives will reduce the dielectric ceramics Q_u , The right adhesives can reduce Q_u to a minimum, while ensuring the adhesion strength.



Order Codes

Order Codes TE01 δ Mode (TE)

TE	36	-	10	A	S
Part Number	Dielectric Constant		Center Frequency (GHz)	Configuration	
				A	With hole
				B	Without hole
				Construction	
				S	Support
				W	Without support



▶ General Information

Advantage of Token's Microwave Dielectric Components

New Microwave Dielectric Materials for Wireless Communication from Token Electronics

"Everything from the electromagnetic properties to microstructure of the material is important for the final result"

A small ceramic component made from a dielectric material is fundamental to the operation of filters and oscillators in several microwave systems, such as satellite TV receivers, military radar systems, Global Positioning System (GPS) devices, and mobile communications. Token Electronics had been able to develop specialized piezoelectric materials which lead to more reliable and clearer microwave communication signals.

In microwave communications, dielectric components are used to discriminate between wanted and unwanted signal frequencies in the transmitted and received signal. When the wanted frequency is extracted and detected it is necessary to maintain a strong signal nevertheless. For clarity it is also critical that the wanted signal frequencies are not affected by seasonal temperature changes.

The resonator materials for practical applications have to have certain key properties. A high relative dielectric constant is needed so that the materials can be miniaturized and a high quality factor (Q) is needed for improved selectivity. Low temperature variation of the material's resonant frequency is also required so that the microwave circuits remain stable.

Although large numbers of ceramic dielectric materials have been developed, it has proven difficult to satisfy all these requirements in a single material at a reasonable cost. "Token takes the advantages of these new materials that they are relatively cheap compared with some of the compounds currently used and in the future they can be improved even further by suitable additives and by optimizing the preparation conditions."

Dielectric Material Composition & Study

The new dielectric materials developed by Token, are based on ceramics formed by baking the pressed powdered starting material mixture in a furnace at between 1200 and 1550 degrees Celsius.

Token Engineers used X-ray diffraction studies, Raman spectroscopy and scanning electron microscopy to reveal the structure of the ceramics. The materials have the general formula $Ce(M_{1/2}Ti_{1/2})O_{3.5}$. Ce is the element cerium, Ti is titanium and O is oxygen. "M" represents any one of the metals magnesium, zinc, calcium, cobalt, manganese, nickel or tungsten. The numbers refer to the proportions of each element in the ceramic.

"Further work is in progress to find the exact composition, internal structure and secondary phases in the ceramics".

Token's Service & PDF Catalogue Download

Token reliably deliver high-quality microwave dielectric components according to the each customer special needs with respect to performance, costs, and technology modifications.

For marketing discontinuations or sourcing activities concerning dielectric products, you are encouraged to contact our Sales Department so the request can be properly directed within Token.

