

Version:
July 21, 2017

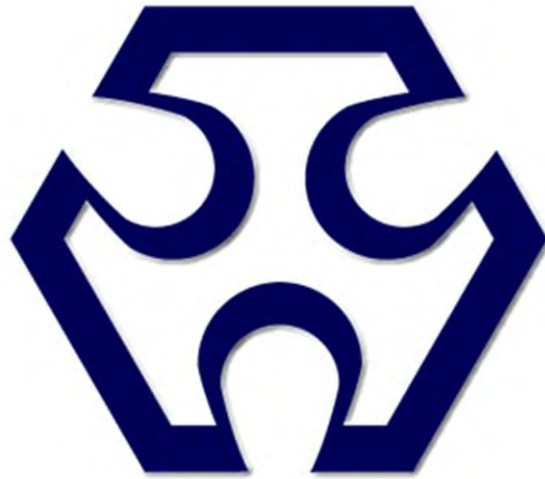

TOKEN

(LT10.7M)

Ceramic Filters

Token Electronics Industry Co., Ltd.

Taiwan: No.137, Sec. 1, Zhongxing Rd., Wugu District,
New Taipei City, Taiwan, R.O.C. 24872
Tel: +886 2981 0109 Fax: +886 2988 7487

China: 12F, Zhong Xing Industry Bld., Chuang Ye Road,
Nan Shan District, Shen Zhen City,
Guang Dong, China 518054
Tel: +86 755 26055363; Fax: +86 755 26055365

[Web: www.token.com.tw](http://www.token.com.tw)

[Email: rfq@token.com.tw](mailto:rfq@token.com.tw)



▶ Product Introduction

Token (LT10.7M) ceramic filters are compatible with Murata SFELF10M7.

Features :

- Change in center frequency is typically within $\pm 30\text{ppm}/^\circ\text{C}$ at -20°C to $+80^\circ\text{C}$.
- Various band widths are available for applications in wide to narrow bands.
- Low loss, favorable waveform symmetry, and high selectivity.
- These miniature filters have high mechanical strength.
- Excellent shape factor of frequency response.
- Small dispersion and stable characteristics.
- Good waveform symmetry.
- High reliability.

Token LT10.7M series are monolithic devices which utilize the energy-trapped thickness vibration-mode. This principle of operation is based upon the fact that an excellent resonating element with low spurious vibration can be obtained by adhering to certain theoretical parameters of design. These parameters include the physical dimensions of the peizo element, the electrode pattern, and the associated mass loading effect of the electrodes.



Token categorizes the LT 10.7 family according to rank of center frequency. This ranking indicates that a given LT 10.7 will be marked with one of the colors listed in the following chart and will exhibit the center frequency in Technical Characteristics Table.

The (LT10.7M) offers three series: LT10.7M for FM Receiver (Compatible Murata SFELF10M7), LT10.7M A10 Insertion Loss $2.5\pm 2.0\text{ dB} \sim 4.5\pm 2.0\text{ dB}$ (Compatible Murata SFELF10M7 A10), and LT10.7M Wide Band-width 950 kHz at 20dB/Narrow Band-width 95 kHz at 20dB (Compatible Murata Filter SFELF10M7 DBS Receiver).

(LT10.7M) Narrow Band-width series features stable low spurious and temperature characteristics. This series is suitable for European car-audio or AM up conversion use that needs narrow band characteristics are stable. LT10.7M Wide Band-width series are specified to make up conventional ceramic filters which wider band characteristics not obtained.

Custom parts are available on request. Token will also produce devices outside these specifications to meet specific customer requirements, please contact our sales or link to Token official website "[Ceramic Filters](#)" for more information.



► Dimensions

Dimensions (Unit: mm) (LT10.7M)

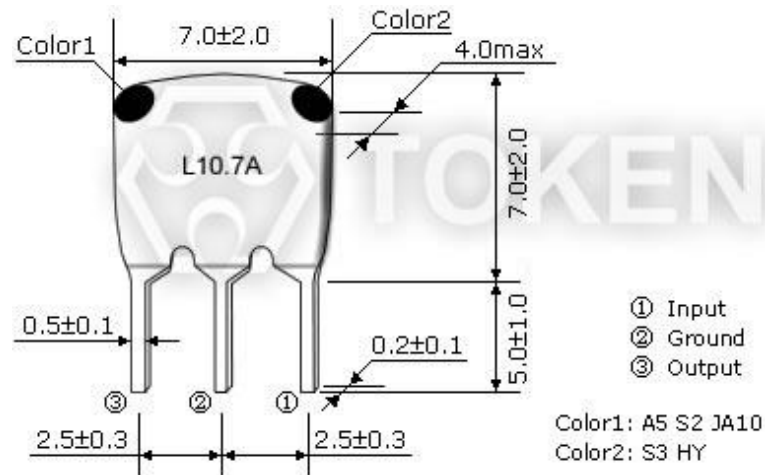

Dimensions

LT10.7Mxx Serial W*H: $7.0 \pm 2.0 * 7.0 \pm 2.0$ mm

LT10.7MFP W*H: $10.0 \pm 2.0 * 10.0 \pm 2.0$ mm

► Technical Characteristics

(LT10.7M) For FM Receiver (Murata SFE10M7 FM-IF Compatible)

Part Number	3dB Band Width (kHz)	20dB Band Width (kHz) max	Insertion Loss (dB) max	Spurious Attenuation (9-12MHz)(dB)min
LT10.7MA5	280±50	650	6	30
LT10.7MS2	230±50	600	6	40
LT10.7MS3	180±40	520	7	40

- Input/Output Impedance: 330Ω

(LT10.7M A10) Low Insertion Loss (Murata SFE10M7 A10 Compatible)

Part Number	3dB Band Width (kHz)	20dB Band Width (kHz) max	Insertion Loss (dB)	Spurious Attenuation (9-12MHz)(dB)min
LT10.7MA5A10	280±50	590	2.5±2.0	30
LT10.7MS2A10	230±50	520	3.0±2.0	35
LT10.7MS3A10	180±40	470	3.5±1.5	35
LT10.7MJA10	150±40	360	4.5±2.0	35

- Input/Output Impedance: 330Ω

(LT10.7M) Wide/Narrow Band-width (Murata SFE10M7 DBS Receiver Compatible)

Part Number	3dB Band Width (kHz)	20dB Band Width (kHz) max	Insertion Loss (dB)	Spurious Attenuation (9-12MHz)(dB)min
LT10.7MA19	350min	950	3.0±2.0	20
LT10.7MA20	330±50	680	4.0±2.0	30
LT10.7MHY	110±30	350	7.0±2.0	30
LT10.7MFP	20min	95	6.0max	24(10.7±1.0MHz)

- Input/Output Impedance: 470Ω(MA19), 330Ω(MA20,MHY), 600Ω(MFP)

Characteristics (LT10.7M)

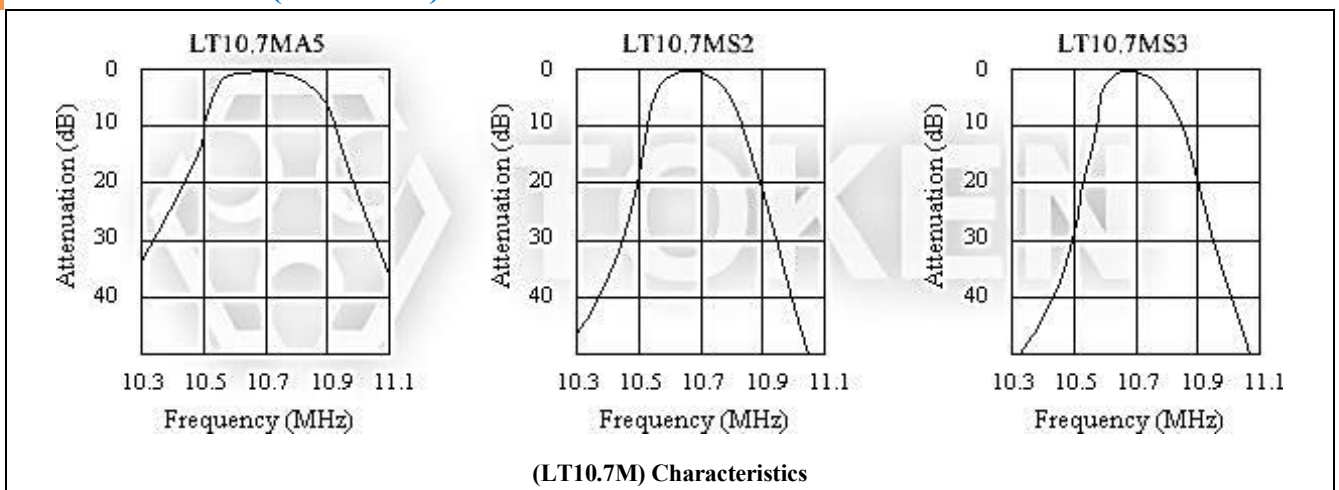

▶ Test Circuit

Matching Conditions & Test Circuit (LT10.7M)

- When using filters, it is most important to match the input/output load to impedance 330 ohm (LT10.7MA19 is 470 ohm matching). Waveform symmetry is damaged when reactance is added to the input/output load.
- Two filters directly connected can be used for high selectivity. For reducing waveform variation, it is recommended to input a buffer AMP between filters.
- The LT10.7M series are of input/output symmetric structure so that in theory there is no input/output directionality. Actual circuits may use different input/output loading conditions (for example, mismatched impedance) or capacitance load. In such cases, the waveform will be a little changed by the direction of the input/output of the filter.

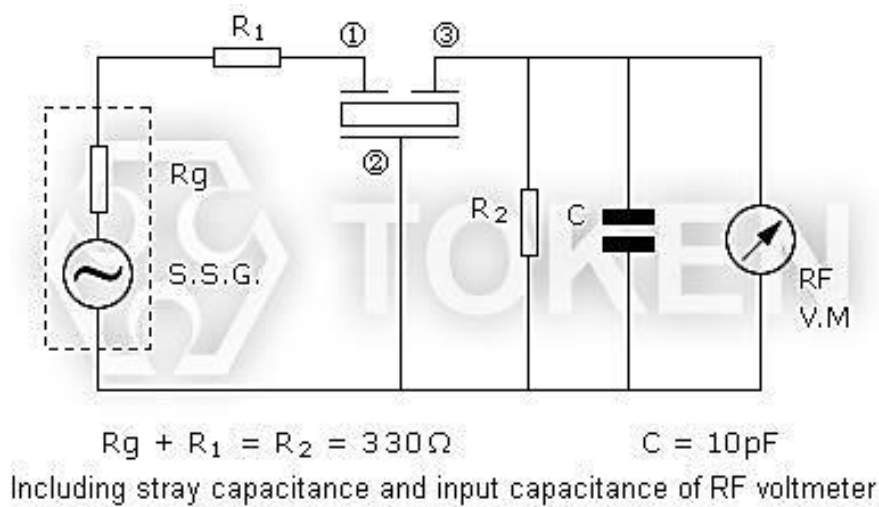

(LT10.7M) Test Circuit

▶ Standard Marking Color

Standard Marking Color (LT10.7M)

Center Frequency	Color
D:10.64MHz±30kHz	Black
B:10.67MHz±30kHz	Blue
A:10.70MHz±30kHz	Red
C:10.73MHz±30kHz	Orange
E:10.76MHz±30kHz	White

Order Codes

Order Codes (LT10.7M)

LT10.7MA5	-	A	P
Part Number		Center Frequency color code	Package
LT10.7MA5		A 10.70MHz±30kHz Red	P Bulks
LT10.7MS2		B 10.67MHz±30kHz Blue	TB Tab Box
LT10.7MS3		C 10.73MHz±30kHz Orange	
LT10.7MA5A10		D 10.64MHz±30kHz Black	
LT10.7MS2A10		E 10.76MHz±30kHz White	
LT10.7MS3A10			
LT10.7MJA10			
LT10.7MA19			
LT10.7MA20			
LT10.7MHY			
LT10.7MFP			

▶ General Information

Introduction of Filters

For more than two decades, piezo technology has been instrumental in the proliferation of solid state electronics. A view of the future reveals that even greater expectations will be placed on piezoelectric material in the area of new applications and for more stringent performance criteria in modern products.

Token sophisticated ceramics technology has greatly increased selectivity and wide-band characteristics, and has stabilized the characteristics of ceramic filters. The series covers a wide range of attenuation and bandwidths to allow selection of the most optimum filter characteristics for each application.

Token filters are band pass filters consisting of one or more ceramic resonators connected in a ladder network configuration. Pass band characteristics are determined by the relative resonant and anti-resonant frequencies of the resonators. Both narrow and wide pass band configurations are manufactured by adjusting the resonator frequency characteristics.

The IC (Integrated Circuit) has found wide use in the field of commercial equipment, such as automotive radios, stereo systems, 2-way communications, TV sets, etc. Thus, new miniature integrated filters, with high performance, are extremely desirable for use in IF circuits.

Furthermore, radio wave disturbance due to rapid progress of data transmitting rate and remarkable sophistication of communication network have become significant traffic conflicts. Accordingly, the demand for filters with high selectivity and wide pass band width has boosted.

The IC application of the active elements will continue its progress, and there will be a growing demand for highly selective, non-adjustable, miniature and wide pass band width IF circuit.

Advantage of Token Piezoelectric Filters

Token Electronics had been able to develop specialized piezo materials which when combined with an advance design have resulted in a complete line of practical, inexpensive piezo devices for entertainment and communications applications.

Token reliably deliver high-quality components according to the each customer special needs with respect to performance, costs, and technology modifications.

For marketing discontinuations or sourcing activities concerning Piezoelectric Filter products, you are encouraged to contact our Sales Department so the request can be properly directed within Token.

