

Version:
November 23, 2017



General Resistor Series

Token Electronics Industry Co., Ltd.

Taiwan: No.137, Sec. 1, Zhongxing Rd., Wugu District,
New Taipei City, Taiwan, R.O.C. 24872
Tel: +886 2981 0109 **Fax:** +886 2988 7487

China: 12F, Zhong Xing Industry Bld., Chuang Ye Road,
Nan Shan District, Shen Zhen City,
Guang Dong, China 518054
Tel: +86 755 26055363; **Fax:** +86 755 26055365

[Web: www.token.com.tw](http://www.token.com.tw)

[Email: rfq@token.com.tw](mailto:rfq@token.com.tw)



Production Index

General Resistor Series

Resistor Glossary & Terminology	1
Glossary & Terminology	1
Select Optimum Resistors.....	3
Select Optimum Resistors.....	3
Pulse Load Anti-Surge Resistors (RCR)	5
Product Introduction.....	5
General Specifications	6
Power Rating	6
Loading Conditions	7
Order Codes	7
General Information	8
Carbon Film Resistors (CF)	9
Product Introduction.....	9
Dimensions & Specifications	10
Electrical Performance.....	11
Order Codes	11
General Information	12
Light Dependent Resistors (PGM)	13
Product Introduction.....	13
Terminology	14
Physical and Environmental Characteristics	15
Configurations & Dimensions	16
PGM5**** Electronics Characteristics	17
PGM55** Electronics Characteristics	17
Configurations & Dimensions	18
PGM12** Electronics Characteristics	19
PGM12**-MP Electronics Characteristics	19
Configurations & Dimensions	20
PGM20** Electronics Characteristics	21
PGM20**-PP Electronics Characteristics	21
Order Codes	21
General Information	22
Ceramic Housed Cement Resistors (SQ)	23
Product Introduction.....	23
SQP Dim.	24
SQM Dim.	25
SQT Dim.	26
SQH Dim.	27
SQZ Dim.	28
Electrical Performance.....	29
Material Specifications	29
Order Codes	29
General Information	30



Carbon Composition Resistors (CCR)	31
Product Introduction.....	31
Dimensions	32
Ratings Specifications.....	32
Derating Curve	33
Performance.....	34
Order Codes	34
General Information	35
Fusible Resistors (FRN, FKN, FSQ)	36
Product Introduction.....	36
Specifications (FRN).....	37
Specifications (FKN)	38
Specifications (FSQ)	38
Characteristics	39
Application Notes.....	40
Order Codes	40
General Information	41
Metal Oxide Resistors (RSS, RSN).....	42
Product Introduction.....	42
Specifications & Dimensions	43
Electrical Performance.....	44
Application Notes.....	44
Order Codes	45
General Information	46
Precision Resistors (MF)	47
Product Introduction.....	47
Dimensions & Specifications	48
Resistance Range.....	49
Electrical Performance.....	49
Order Codes	50
General Information	51
Product Introduction.....	52
General Specifications	53
Electrical Performance.....	54
Order Codes	54
General Information	55
Wire wound Resistor (KNP-VE).....	56
Product Introduction.....	56
Technical Specifications	57
Electrical Performance.....	58
Application Notes.....	58
Order Codes	58
General Information	59
Wire Wound Resistors (KNP)	60
Product Introduction.....	60
General Specifications	61
Electrical Performance.....	62



Application Notes.....	63
Order Codes.....	63
General Information.....	64
Non-Inductive Wire wound Resistor (KNPN).....	65
Product Introduction.....	65
General Specifications.....	66
Electrical Performance.....	67
Application Notes.....	68
Order Codes.....	68
General Information.....	69
Power Wire wound Resistor (KNP-R).....	70
Product Introduction.....	70
Technical Specifications.....	71
Electrical Performance.....	72
Application Notes.....	72
Order Codes.....	72
General Information.....	73
High Precision Wire wound Resistor (BWW).....	74
Product Introduction.....	74
Technical Specifications.....	75
Electrical Performance.....	76
Application Notes.....	76
Order Codes.....	76
General Information.....	77
Zero Ohm & Jumper Wire Resistors (ZO, JW).....	78
Product Introduction.....	78
ZO General Specification.....	79
JW General Specification.....	79
Electrical Performance.....	80
Order Codes.....	80
General Information.....	81
Heating Resistors (HR).....	82
Product Introduction.....	82
Dimensions.....	83
Specifications.....	84
Electrical Specifications.....	84
Advantage Heat Resistors.....	85
Order Codes.....	85



Resistor Glossary & Terminology

► Glossary & Terminology

Resistor Glossary & Terminology

Fusible Resistor (Fuse Resistor, Circuit Protect Resistor)

A resistor designed to protect a circuit against overload; its resistance limits current flow and thereby protects against surges when power is first applied to a circuit; its fuse characteristic opens the circuit when current drain exceeds design limits.

Thermal Cutoff Resistor

A thermal fuse is a cutoff which uses a one-time fusible link. Unlike the thermostat which automatically resets itself when the temperature drops, the thermal fuse is more like an electrical fuse: a single-use device that cannot be reset and must be replaced when it fails or is triggered. A thermal fuse is most useful when the overheating is a result of a rare occurrence, such as failure requiring repair (which would also replace the fuse) or replacement at the end of service life.

Token offers "Thermal Cut-off Resistor", a thermal Cut-offs is a fusible alloy and a resistor is a voltage divider, both are surrounded by ceramic cement with special resin. Under normal operating temperatures the fusible alloy joins the two lead wires within the body of the cutoff and the power resistor acts as a normal function resistor. When the preset temperature of the cutoff is reached, the fusible alloy melts and with the aid of the special resin, complete cutoff is ensured.

Thermal fuse resistors are usually found in heat-producing electrical appliances such as coffeemakers and hair dryers. They function as safety devices to disconnect the current to the heating element in case of a malfunction (such as a defective thermostat) that would otherwise allow the temperature to rise to dangerous levels, possibly starting a fire.

Anti-Surge Resistor (RCR)

Surges in electronic circuits are caused by internal conditions — switching operations from other electronic components or due to external conditions on the AC power mains — switching operations in the power grid or from nearby lightning strikes, either directly to the power distribution system or to nearby ground. Electronic products have to be surge immune to ensure their continued reliable operation if subjected to realistic levels of surge voltages, and they are required to comply with safety requirements. Token's RCR series is a perfect fit when an anti-surge resistor is required.

Light Dependent Resistor (LDR)

A photoresistor or light dependent resistor or cadmium sulfide (CdS) cell is a resistor whose resistance decreases with increasing incident light intensity. It can also be referenced as a photoconductor.

A photoresistor is made of a high resistance semiconductor. If light falling on the device is of high enough frequency, photons absorbed by the semiconductor give bound electrons enough energy to jump into the conduction band. The resulting free electron (and its hole partner) conduct electricity, thereby lowering resistance.



Carbon Composition Resistor (CCR)

CCR is made up of a solid rod of conductive composite material, the chemical composition of which is altered to produce different resistance values. The general composition consists of the carbon conductor and ceramic filler materials. By altering the ratio of filler to conductor it is possible to change the resistance value. Interference-fit end caps are attached to the rods, leads are welded onto these caps, and the resistor body is then protected with a specially formulated epoxy coating. The resistors are then color code marked.

Ayrton-Perry Winding

Winding of two wires in parallel but opposite directions to give better cancellation of magnetic fields than is obtained with a single winding.

Wire wound technology has long been known as a leading technology for power resistor needs. The most critical drawback with this technology is that it is inherently inductive. This is logical given that a wire wound inductor and wire wound resistors are made with essentially the same materials and processes. This fact limits the use of wire wounds for applications with high switching speeds, which require low inductance.

Now the same standard wire wounds can be used for these applications by using a non-inductively wound version. This manufacturing method greatly reduces the inductance of any given resistor size and value combination, however it does not completely eliminate the inductance. A non-inductively wound wire wound has one winding in one direction and one in the other direction; known as Ayrton Perry winding. This non-inductive winding is available in all Token standard wire-wound resistor series.



Select Optimum Resistors

► **Select Optimum Resistors**

Select Resistors with Optimum Technology to Best Match the Performance

Comparison of Axial Lead Resistor Functions Table		
Class	Advantage	Disadvantage
Carbon Resistors	Cheap, General Purposes	High TCR,
Metal Film Resistors	Low TCR, Tight Tolerance, High Stability	Fair Withstanding Voltage
Metal Oxide Resistors	Replace high resistance wire wound resistor, Good withstanding voltage	Resistance Range Limitation, Fair Tolerance
Wire wound Resistors	High Pulse Load, Anti-Surge, High Stability	High Inductance, Resistance Range Limitation
Non-Inductive Resistors	High Pulse Load, Anti-Surge, High Stability	Resistance Range Limitation, High Cost
Ceramic Housed Cement Resistors	Rugged, excellent heat dissipation, withstanding high temperature	Heavy Weight, Big Volume
Metal Glaze Resistors	High Pulse Load, Anti-Surge, High Stability	High TCR, Fair Tolerance
Alloy Strip	Low TCR, Low Ohmic	Fair Tolerance



Comparison of Axial Lead Resistor Characteristics Table								
Characteristics		Thin Film		Thick Film		Wire Wound		Alloy Strip
		Carbon Film	Metal Film	Metal Oxide Film	Metal Glaze Film	Standard	Non-Inductive	
Tolerance (%)	±0.01		√			√		
	±0.02		√			√		
	±0.05		√			√		
	±0.1		√			√		
	±0.25		√			√		
	±0.5		√			√		
	±1.0		√		√	√	√	√
	±2.0	√		√	√	√	√	√
	±5.0	√		√	√	√	√	√
±10	√		√	√	√	√	√	
Temperature Coefficient (PPM/°C)	5		√					
	10		√					
	15		√					
	25		√			√		√
	50		√			√	√	√
	100		√		√	√	√	√
	200	√		√	√	√	√	
	400	√		√	√	√	√	
	1,000	√						
Operating Temperature Range (°C)	200			√				√
	165		√	√	√	√	√	√
	125	√	√	√	√	√	√	√
	70	√	√	√	√	√	√	√
	40	√		√	√	√	√	√
	10	√		√	√	√	√	√
Wattage (W)	1/16							
	1/8	√	√					
	1/4	√	√	√	√	√		
	1/2	√	√	√	√	√	√	√
	1	√	√	√	√	√	√	√
	2	√	√	√	√	√	√	√
	3	√	√	√	√	√	√	√
	5			√	√	√	√	
	10			√	√	√	√	
Resistance Range (Ω)	0.1							
	1		√			√		√
	10	√	√	√	√	√	√	
	100	√	√	√	√	√	√	
	1K	√	√	√	√	√	√	
	10K	√	√	√	√	√		
	100K	√	√		√	√		
	1M	√	√		√	√		
	10M	√			√	√		
Volume Size	Standard	Standard	Standard	Standard	Standard	Bigger	Compact	
High Frequency	Available	Available	Available	Available	None	Available	Available	
Cost	Cheap	Fair	Fair	Fair	High	High	Fair	
Noise	Fair	Good	Fair	Fair	Fair	Good	Good	
Stability	Fair	Excellent	Good	Good	Excellent	Good	Excellent	



Pulse Load Anti-Surge Resistors (RCR)

▶ Product Introduction

||| Thick-film anti-surge resistor handles large pulse loading.

Features :

- High power at small sizes
- Max working voltage up to 3000V
- Lead (Pb)-free and RoHS compliant
- Operating temperature range: $-20^{\circ}\text{C} \sim +155^{\circ}\text{C}$
- Metal glaze power film, axial leaded type
- Max overload voltage 5000V, Tolerances: J ($\pm 5\%$)

Applications :

- Ballasts
- Amplifiers
- Industrial power supplies
- Telecommunications
- Household appliances
- Automotive circuits, Computer, Instrumentation

A new range of anti-surge axial leaded power resistors, metal glaze resistive element on ceramic substrates, from Token Electronics.

A carbon film resistor replacement, the new RCR series thick-film style resistors offer numerous benefits over the previous style devices, namely reduced costs, excellent thermal compliance, optimized a variety of surge capabilities and better solder joint reliability against temperature cycles.

Token succeeded in commercializing the compact thick-film type leaded resistors with high power and high anti surge characteristics, meeting latest design engineer requirements and making the parts suitable for industrial, measurement and telecommunication applications as well as for automotive circuits, like Electrical Control Units (ECU) and Air-Bag Systems.

The anti-surge characteristics of Token's latest metal glaze power film style resistors are superior to standard metal film resistors. The power film types of RCR resistors are available: 0.25W to 10W power rating, max working voltage up to 3000V and max overload voltage 5000V. The resistance range is $1\Omega \sim 100\text{M}\Omega$ at operating temperature range $-20^{\circ}\text{C} \sim +155^{\circ}\text{C}$.

All RCR series devices are RoHS-compliant, and compatible with high temperature soldering processes normally employed for lead free solders. Resistors are also available in various forming styles and different leads for different applications. Contact us with your specific needs. For more information, please link to Token official website "[General Purpose Resistors](http://www.token.com.tw)".



General Specifications

General Specifications (RCR) (Unit: mm)

Type	Power Rating	L	D	d ± 0.05	H
RCR25	1/4W	6.5±1	2.3±0.5	0.5 ~ 0.6	26±3
RCR50	1/2W	9.5±1	3.4±0.5		
RCR100	1W	12.0±1	4.0±0.5	0.7 ~ 0.8	
RCR200	2W	16.0±1	6.1±0.5		
RCR300	3W	17.0±1	7.0±0.5		
RCR500	5W	24.0±1	8.0±0.5		
RCR1000 *	10W	max.50	max.10		

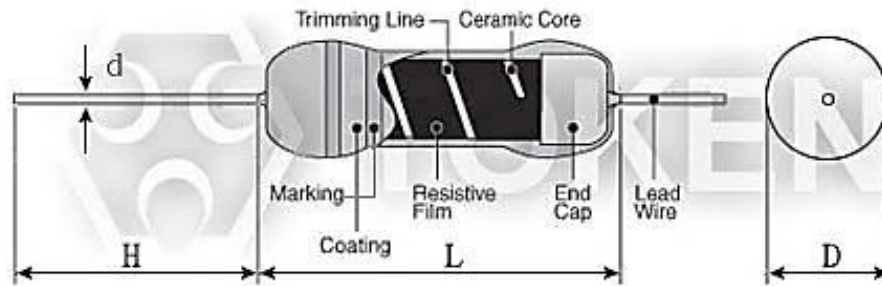

Anti-Surge (RCR) Dimensions (Unit: mm)

● Remark: RCR1000 is custom design and on request.

Power Rating

Anti-Surge Resistors (RCR)

Type	Power Rating	Max Working Voltage	Max Overload Voltage	Dielectric With-standing Voltage	TCP.(ppm/°C)	Resistance Range E24.J(±5%)(Ω)	Operating Temperature
RCR25	1/4W	500V	700V	500V	±350	1 ~ 33M	-20°C ~+155°C
RCR50	1/2W	1000V	1500V	600V	±350	1 ~ 68M	
RCR100	1W	1500V	2500V	800V	±350	1 ~ 100M	
RCR200	2W	2000V	3000V	800V	±350	1 ~ 100M	
RCR300	3W	2500V	4000V	1000V	±350	1 ~ 100M	
RCR500	5W	3000V	5000V	1000V	±350	1 ~ 100M	

▶ Loading Conditions

Anti-Surge Resistors (RCR)

Power	Resistance Range (Ω)	Surge Voltage	Anti-Surge Characteristics	Surge Test Condition
0.25 W	50K < R	3KV	(2.5 Sec. ON + 2.5 Sec. Off) × 10 Cycles ; ΔR ≤ ±(50%R+0.1Ω)	In accordance with IEC 65 Safety specification.
0.5 W	10K ≤ R < 100K	3KV		
	100K ≤ R < 360K	5KV		
	360K ≤ R < 1M	7KV		
	1M ≤ R	10KV		

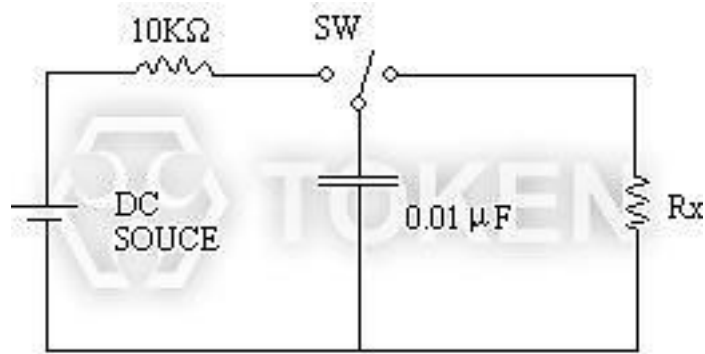

Test Circuit

Anti-Surge (RCR) Test Circuit

▶ Order Codes

Anti-Surge Resistors (RCR)

RCR50	1/2W	220KR	J	TB
Part Number	Rated Power (W)	Resistance Value (Ω)	Resistance Tolerance (%)	Package
RCR		1R0 1.0Ω	J ±5%	P Bulk
		100R 100Ω		TB Taping Box
		220K 220KΩ		
		22M 22MΩ		

▶ General Information

General Purpose Resistors with Customized Service

Token Electronics is expanding business to include a broad range of General Purpose Resistor products designed for high volume applications. This expanded range of commercial resistor presents a more comprehensive product offering for Customer Experience Management (CEM) and other high volume customers that require quality products at competitive pricing.

Backed by the same customer service, technical support and quality assurance that Token has always provided, these new commercial products enable you the opportunity to source a wider range of resistors from a trusted supplier.

General Use

When an ambient temperature exceeds a rated ambient temperature, resistor shall be applied on the derating curve by derating the load power. General purpose resistor under overloads is not combustion resistant and is likely to emit, flame, gas, smoke, red heat, etc. Flame retardant resistor generally emits smoke and red heat in a certain power and over but do not emit fire or flame.

When resistors are shielded or coated with resin etc., stress from the storage heat and the resins are applied. So, performance and reliability should be checked well before use.

When a voltage higher than rated is applied in a short time (single pulse, repeated pulses, surge, etc.), it does not necessarily ensure safety that an effective wattage is not higher than a rated wattage. Then consult with us with your specified pulse wave shape. Resistors shall be used in a condition causing no dew condensation.

Keep temperature from rising by choosing resistor with a higher rated capacity; do not use a component having the exact load value required. For considerations of safety in extended period applications, the rating should be more than four times higher than the actual wattage involved, but never use resistors at less than 25% of its rated power.

In applications where resistors are subject to intermittent current surges and spikes, be sure in advance that the components selected are capable of withstanding brief durations of increased load.

Do not exceed the recommended rated load. Resistor must use within the rated voltage range to prevent the shortening of service life and/or failure of the wound resistance elements.

Minimum load: Resistor must be utilized at 1/10 or more of the rated voltage to prevent poor conductance due to oxidation build-up. For basic particulars for cautions, refer to EIAJ Technical Report RCR-2121 "Guidance for care note on fixed-resistors".



Carbon Film Resistors (CF)

► Product Introduction

||| **Pulse load carbon film resistor is the cost-effective option.**

Features :

- Tolerances: G ($\pm 2\%$), J ($\pm 5\%$)
- Power wattages up to 5W at $+25^{\circ}\text{C}$
- Lead (Pb)-free and RoHS compliant
- Operating temperature range: $-55^{\circ}\text{C} \sim +155^{\circ}\text{C}$
- Axial leaded type, high power at small sizes

Applications :

- Consumer Electronic
- Telecommunications
- Household Appliances
- Automotive, Computer, Instrumentation

Providing design engineers with an economical power resistor with high quality performance, Token Electronics now offers commercial grade low power carbon film resistors.

Designated the CF series, the resistors are available in both standard CF and miniature CFS sizes, the conformal coated resistors offer high quality performance for applications that do not require surge protection or precision tolerances.

The commercial grade carbon CF series is available in flame retardant packaging and have ideal specifications for consumer electronic or electrical devices. The CF devices offer a wide resistance range for devices with power ratings up to 3W in standard CF size, and 5W in miniature CFS sizes, delivering high quality performance for general purpose applications.

The CF series resistors are ideal for general use applications including electrical equipment, small appliances and consumer electronics, such as televisions and other high-volume products. The CF series feature standard tolerances is G ($\pm 2\%$) and J ($\pm 5\%$), with a resistance range from 0.5Ω to $22\text{M}\Omega$.

All CF series devices are RoHS-compliant, and compatible with high temperature soldering processes normally employed for lead free solders. Also, CF resistors are available in various forming styles and different leads for different applications. Contact us with your specific needs. For more information, please link to Token official website "[General Purpose Resistors](http://www.token.com.tw)".



► Dimensions & Specifications

Dimensions & Specifications (Unit: mm) (CF)

Type		Dimension (mm)				Maximum Working Voltage	Maximum Overload Voltage	Resistance Tolerance	
CF	CFS	L	D	H	d±0.05			± 2%(G)	± 5%(J)
1/8 W	.	3.2±0.2	1.5±0.2	26±1	0.40~0.45	200	400	10Ω-470K	1Ω-4.7M
1/6 W	1/4 W	3.2±0.2	1.5±0.2	26±1	0.40~0.45	200	400	1Ω-10M	0.5Ω-22M
1/4 W	1/2 W	6.2±0.5	2.3±0.3	26±1	0.40~0.50	250	500	1Ω-10M	0.5Ω-22M
1/3 W	1/2 W	8.5±0.5	2.8±0.3	26±1	0.50~0.55	250	500	1Ω-10M	0.5Ω-22M
1/2 W	1 W	9.0±0.5	3.0±0.5	26±1	0.50~0.55	350	700	1Ω-10M	0.5Ω-22M
1 W	2 W	11±1.0	4.0±0.5	35±3	0.75~0.80	500	1000	1Ω-10M	0.5Ω-22M
2 W	3 W	15±1.0	5.0±0.5	35±3	0.75~0.80	500	1000	1Ω-10M	0.5Ω-22M
3 W	5 W	17±1.0	6.0±0.5	35±3	0.75~0.80	500	1000	1Ω-10M	0.5Ω-22M

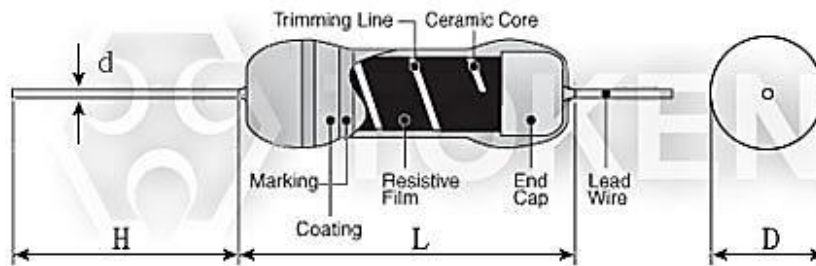

Carbon Film (CF) Dimensions (Unit: mm)

Electrical Performance

Electrical Performance (CF)

Test Items	Condition	Spec
Operating Temp.range	-55℃ ~ +155℃	
Short Time Over Load	2.5 Times of rated voltage for 5sec.	± 1%
Load Life	70 ℃ on-off cycle 1,000hrs.	± 5%
Moisture-Proof Load Life	40 ℃ 95% RH on-off cycle 1,000hrs	± 5%
Soldering After Resistance	350 ℃ for 3sec.	± 0.5%
Temperature Cycle	-30 ℃~85 ℃ 5cycles	± 2%
Resistance Temperature Coefficient	1Ω~22KΩ 22KΩ~510KΩ 510KΩ~1MΩ 1MΩ~2.2MΩ 2.2MΩ~5.1MΩ	± 300PPM / ℃ ± 450PPM / ℃ ± 800PPM / ℃ ± 1000PPM / ℃ ± 1400PPM / ℃

Order Codes

Order Codes (CF)

CF	0.125W	100R	J	TB
Part Number	Rated Power (W)	Resistance Value (Ω)	Resistance Tolerance (%)	Package
CF		1R 1Ω	G ±2%	TB Taping Box
CFS		10R 10Ω	J ±5%	
		100R 100Ω		
		10K 10KΩ		
		10M 10MΩ		
		22M 22MΩ		



► General Information

General Purpose Resistors with Customized Service

Token Electronics is expanding business to include a broad range of General Purpose Resistor products designed for high volume applications. This expanded range of commercial resistor presents a more comprehensive product offering for Customer Experience Management (CEM) and other high volume customers that require quality products at competitive pricing.

Backed by the same customer service, technical support and quality assurance that Token has always provided, these new commercial products enable you the opportunity to source a wider range of resistors from a trusted supplier.

General Use

When an ambient temperature exceeds a rated ambient temperature, resistor shall be applied on the derating curve by derating the load power. General purpose resistor under overloads is not combustion resistant and is likely to emit, flame, gas, smoke, red heat, etc. Flame retardant resistor generally emits smoke and red heat in a certain power and over but do not emit fire or flame.

When resistors are shielded or coated with resin etc., stress from the storage heat and the resins are applied. So, performance and reliability should be checked well before use.

When a voltage higher than rated is applied in a short time (single pulse, repeated pulses, surge, etc.), it does not necessarily ensure safety that an effective wattage is not higher than a rated wattage. Then consult with us with your specified pulse wave shape. Resistors shall be used in a condition causing no dew condensation.

Keep temperature from rising by choosing resistor with a higher rated capacity; do not use a component having the exact load value required. For considerations of safety in extended period applications, the rating should be more than four times higher than the actual wattage involved, but never use resistors at less than 25% of its rated power.

In applications where resistors are subject to intermittent current surges and spikes, be sure in advance that the components selected are capable of withstanding brief durations of increased load.

Do not exceed the recommended rated load. Resistor must use within the rated voltage range to prevent the shortening of service life and/or failure of the wound resistance elements.

Minimum load: Resistor must be utilized at 1/10 or more of the rated voltage to prevent poor conductance due to oxidation build-up. For basic particulars for cautions, refer to EIAJ Technical Report RCR-2121 "Guidance for care note on fixed-resistors".



Light Dependent Resistors (PGM)

► Product Introduction

||| Light-Dependent Photoresistors for Sensor Applications.

Features :

- Quick Response
- Reliable Performance
- Epoxy or hermetical package
- Good Characteristic of Spectrum

Applications :

- Photoswitch
- Photoelectric Control
- Auto Flash for Camera
- Electronic Toys, Industrial Control

The cadmium sulfide (CdS) or light dependent resistor (LDR) whose resistance is inversely dependent on the amount of light falling on it is known by many names including the photo resistor, photoresistor, photoconductor, photoconductive cell, or simply the photocell.

A typical structure for a photoresistor uses an active semiconductor layer that is deposited on an insulating substrate. The semiconductor is normally lightly doped to enable it to have the required level of conductivity. Contacts are then placed either side of the exposed area.

The photo-resistor, CdS, or LDR finds many uses as a low cost photo sensitive element and was used for many years in photographic light meters as well as in other applications such as smoke, flame and burglar detectors, card readers and lighting controls for street lamps.

Providing design engineers with an economical CdS or LDR with high quality performance, Token Electronics now offers commercial grade PGM photoresistor. Designated the PGM Series, the photoresistors are available in 5mm, 12mm and 20mm sizes, the conformal epoxy or hermetical package offer high quality performance for applications that require quick response and good characteristic of spectrum.

Token has been designing and manufacturing high performance light dependent resistors for decades. Our product offerings are extensive and our experience with custom photoresistor is equally extensive. Contact us with your specific needs. For more information, please link to Token official website "[General Purpose Resistors](http://www.token.com.tw)".



Terminology

Terminology (PGM)

- **Light Resistance :**
Measured at 10 lux with standard light A (2854K-color temperature) and 2hr. preillumination at 400-600 lux prior testing.
- **Dark Resistance :**
Measured at 10th seconds after closing 10 lux.
- **Gamma characteristic :**
Under 10 lux and 100 lux and given by

$$\gamma = \log(R_{10}/R_{100}) / \log(100/10) = \log(R_{10}/R_{100})$$

$$R_{10}, R_{100}: \text{resistance at 10 lux and 100 lux.}$$
 The tolerance of γ is ± 0.1 .
- **Pmax :**
Max. power dissipation at ambient temperature of 25°C. At higher ambient temperature, the maximum power permissible may be lowered.
- **Vmax :**
Max. voltage in darkness that may be applied to the device continuously.
- **Spectral peak :**
Spectral sensitivity of photoresistors depends on the wavelength of light they are exposed to and in accordance with figure 'Spectral Response'. The tolerance of spectral peak is $\pm 50\text{nm}$.

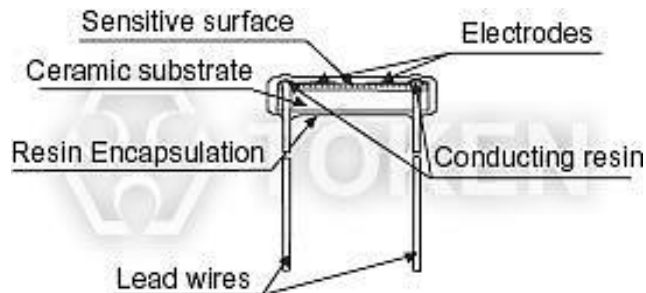

CdS Photoresistor (Light Dependent Resistors) - PGM Series

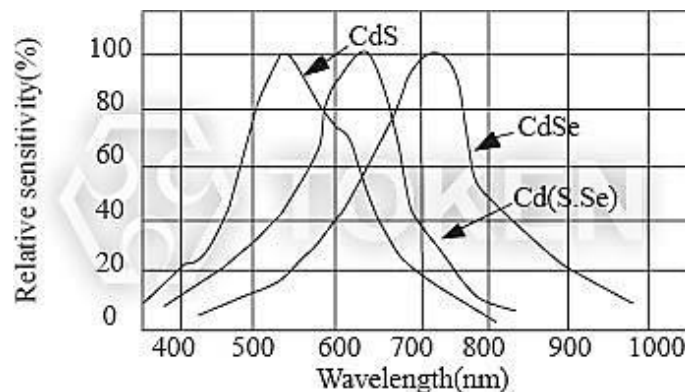

CdS Photoresistors (PGM) Spectral Response



► Physical and Environmental Characteristics

Physical and Environmental Characteristics (PGM)

ITEM	CONDITIONS	PERFORMANCE
Solderability	Put the terminals into welding tank at temp. $230\pm 5^{\circ}\text{C}$ for $2\pm 0.5\text{s}$ (terminal roots are 5mm away from the tin surface).	wetting > 95%
Temperature Changing	Change of temperature in accordance with: TA: -40°C TB: $+60^{\circ}\text{C}$ Number of cycles: 5 Exposure duration: 30min	Drift of R10 = $\pm 20\%$ No visible damage
Constant humidity and heat	1. Put the device in test box at Temperature: $60\pm 5^{\circ}\text{C}$ Humidity: 90-95% Illumination: 0lux Duration: 100h 2. Take the device and measure after 24h at normal temperature and humidity.	Drift of R10 = $\pm 30\%$ No visible damage
Constant load Temperature	At $25\pm 5^{\circ}\text{C}$ Illumination: 150lux at rated power Duration: 600h	No visible damage
Wire Terminals Strength	Bend the wire terminal at its root to 90 degree, and then bend it to a opposite direction.	No visible damage
Vibration	Frequency: 50Hz Swing: 1.5mm with Directions: parallel to ceramic substrate normal to ceramic substrate. Duration: 2h	No visible damage

Configurations & Dimensions

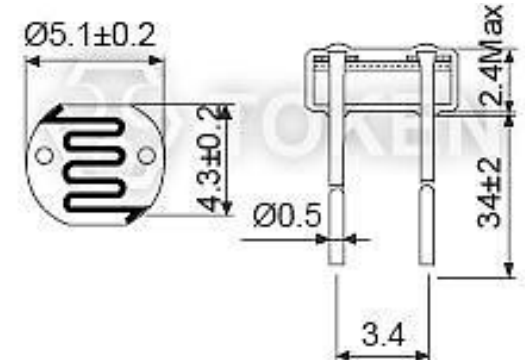
5mm CdS Photo Resistors (PGM) Configurations & Dimensions

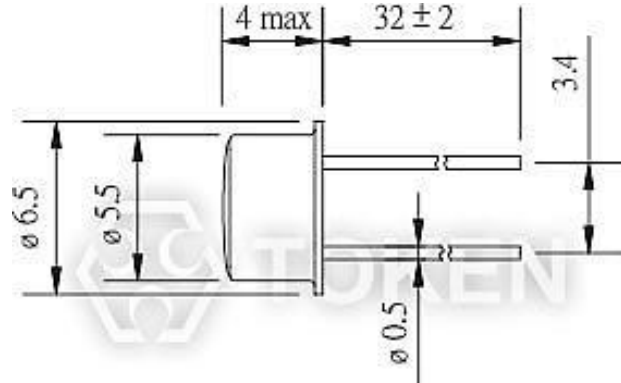
 <p style="text-align: center;">www.token.com.tw</p> <p style="text-align: center;">Epoxy resin package 5mm CdS Photoresistors Appearance PGM5**** series</p>	 <p style="text-align: center;">Epoxy resin package 5mm PGM5**** series Dimensions (Unit: mm)</p>
 <p style="text-align: center;">www.token.com.tw</p> <p style="text-align: center;">Hermetical package 5mm CdS Photoresistors Appearance PGM55**-MP series</p>	 <p style="text-align: center;">Hermetical package 5mm PGM55**-MP series Dimensions (Unit: mm)</p>

● Note: All dimensions are in mm and NTS.

▶ PGM5**** Electronics Characteristics

Epoxy resin package 5mm CdS (PGM5****) Electronics Characteristics

Model	Vmax (VDC)	Pmax (mW)	Ambient Temp (°C)	Spectral Peak (nm)	Photo Resistance (10Lx) (KΩ)	Dark Resistance (MΩ)min	γ _{min}	Response Time (ms)	
								Rise	Decay
PGM5506	100	90	-30 ~ +70	540	2 ~ 6	0.15	0.6	30	40
PGM5516	100	90	-30 ~ +70	540	5 ~ 10	0.2	0.6	30	40
PGM5526	150	100	-30 ~ +70	540	8 ~ 20	1.0	0.6	20	30
PGM5537	150	100	-30 ~ +70	540	16 ~ 50	2.0	0.7	20	30
PGM5539	150	100	-30 ~ +70	540	30 ~ 90	5.0	0.8	20	30
PGM5549	150	100	-30 ~ +70	540	45 ~ 140	10.0	0.8	20	30
PGM5616D	150	100	-30 ~ +70	560	5 ~ 10	1.0	0.6	20	30
PGM5626D	150	100	-30 ~ +70	560	8 ~ 20	2.0	0.6	20	30
PGM5637D	150	100	-30 ~ +70	560	16 ~ 50	5.0	0.7	20	30
PGM5639D	150	100	-30 ~ +70	560	30 ~ 90	10.0	0.8	20	30
PGM5649D	150	100	-30 ~ +70	560	50 ~ 160	20.0	0.8	20	30
PGM5659D	150	100	-30 ~ +70	560	150 ~ 300	20.0	0.8	20	30

▶ PGM55** Electronics Characteristics



Hermetical package 5mm CdS (PGM55**-MP) Electronics Characteristics

Model	Vmax (VDC)	Pmax (mW)	Ambient Temp (°C)	Spectral Peak (nm)	Photo Resistance (10Lx) (KΩ)	Dark Resistance (MΩ)min	γ _{min}	Response Time (ms)	
								Rise	Decay
PGM5506-MP	100	90	-30 ~ +70	540	2 ~ 6	0.15	0.6	30	40
PGM5516-MP	100	90	-30 ~ +70	540	5 ~ 10	0.2	0.6	30	40
PGM5526-MP	150	100	-30 ~ +70	540	8 ~ 20	1.0	0.6	20	30
PGM5537-MP	150	100	-30 ~ +70	540	16 ~ 50	2.0	0.7	20	30
PGM5539-MP	150	100	-30 ~ +70	540	30 ~ 90	5.0	0.8	20	30
PGM5549-MP	150	100	-30 ~ +70	540	45 ~ 140	10.0	0.8	20	30

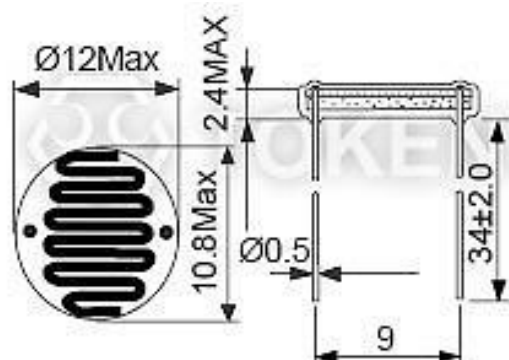

Configurations & Dimensions

12mm CdS Photo Resistors (PGM) Configurations & Dimensions

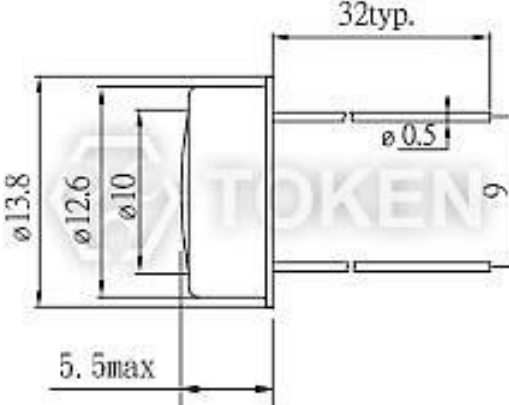
 <p style="text-align: center;">www.token.com.tw</p> <p style="text-align: center;">Epoxy resin package 12mm CdS Photo Resistors Appearance PGM12** series</p>	 <p style="text-align: center;">Epoxy resin package 12mm CdS PGM12** series Dimensions (Unit: mm)</p>
 <p style="text-align: center;">www.token.com.tw</p> <p style="text-align: center;">Hermetical package 12mm CdS Photo Resistors Appearance PGM12**-MP series</p>	 <p style="text-align: center;">Hermetical package 12mm CdS PGM12**-MP series Dimensions (Unit: mm)</p>

● Note : All dimensions are in mm and NTS.

▶ PGM12** Electronics Characteristics

Cds - (PGM12**) Electronics Characteristics

Model	Vmax (VDC)	Pmax (mW)	Ambient Temp (°C)	Spectral Peak (nm)	Photo Resistance (10Lx) (KΩ)	Dark Resistance (MΩ)min	γ min	Response Time (ms)	
								Rise	Decay
PGM1200	250	250	-30 ~ +70	560	2~5	1.0	0.6	30	40
PGM1201	250	250	-30 ~ +70	560	4~10	2.0	0.7	30	30
PGM1202	250	250	-30 ~ +70	560	8~20	5.0	0.7	30	30
PGM1203	250	250	-30 ~ +70	560	18~50	10	0.8	30	30
PGM1204	250	250	-30 ~ +70	560	45~150	20	0.8	30	30
PGM1205	250	250	-30 ~ +70	560	140~300	20	0.8	30	30



▶ PGM12**-MP Electronics Characteristics

Cds - (PGM12**-MP) Electronics Characteristics

Model	Vmax (VDC)	Pmax (mW)	Ambient Temp (°C)	Spectral Peak (nm)	Photo Resistance (10Lx) (KΩ)	Dark Resistance (MΩ)min	γ min	Response Time (ms)	
								Rise	Decay
PGM1200-MP	250	250	-30 ~ +70	560	2~5	1.0	0.6	30	40
PGM1201-MP	250	250	-30 ~ +70	560	4~10	2.0	0.7	30	30
PGM1202-MP	250	250	-30 ~ +70	560	8~20	5.0	0.7	30	30
PGM1203-MP	250	250	-30 ~ +70	560	18~50	10	0.8	30	30
PGM1204-MP	250	250	-30 ~ +70	560	45~150	20	0.8	30	30
PGM1205-MP	250	250	-30 ~ +70	560	140~300	20	0.8	30	30

Configurations & Dimensions

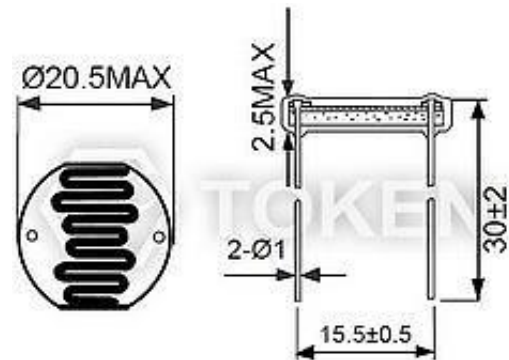
20mm CDS Photo Resistors (PGM) Configurations & Dimensions

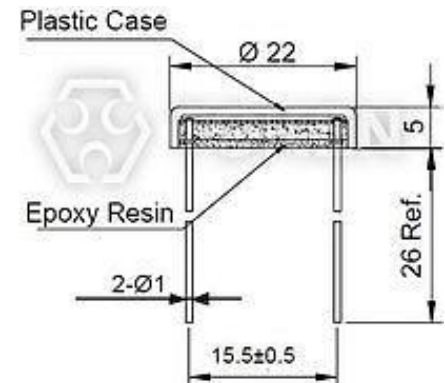
 <p>www.token.com.tw</p> <p>Epoxy resin package 20mm CDS Photo Resistors Appearance PGM20** series</p>	 <p>Epoxy resin package 20mm CdS PGM20** series Dimensions (Unit: mm)</p>
 <p>www.token.com.tw</p> <p>Plastic package 20mm CDS Photo Resistors Appearance PGM20**-PP series</p>	 <p>Plastic package 20mm CdS PGM20**-PP series Dimensions (Unit: mm)</p>

● Note: All dimensions are in mm and NTS.

▶ PGM20** Electronics Characteristics

CdS - (PGM20**) Electronics Characteristics

Model	Vmax (VDC)	Pmax (mW)	Ambient Temp (°C)	Spectral Peak (nm)	Photo Resistance (10Lx) (KΩ)	Dark Resistance (MΩ)min	γ min	Response Time (ms)	
								Rise	Decay
PGM2000	500	500	-30 ~ +70	560	2~5	1.0	0.6	30	40
PGM2001	500	500	-30 ~ +70	560	4~10	2.0	0.7	30	30
PGM2002	500	500	-30 ~ +70	560	8~20	5.0	0.7	30	30
PGM2003	500	500	-30 ~ +70	560	18~50	10	0.8	30	30
PGM2004	500	500	-30 ~ +70	560	45~150	20	0.8	30	30
PGM2005	500	500	-30 ~ +70	560	140~300	20	0.8	30	30

▶ PGM20**-PP Electronics Characteristics

CdS - (PGM20**-PP) Electronics Characteristics

Model	Vmax (VDC)	Pmax (mW)	Ambient Temp (°C)	Spectral Peak (nm)	Photo Resistance (10Lx) (KΩ)	Dark Resistance (MΩ)min	γ min	Response Time (ms)	
								Rise	Decay
PGM2000-PP	500	500	-30 ~ +70	560	2~5	1.0	0.6	30	40
PGM2001-PP	500	500	-30 ~ +70	560	4~10	2.0	0.7	30	30
PGM2002-PP	500	500	-30 ~ +70	560	8~20	5.0	0.7	30	30
PGM2003-PP	500	500	-30 ~ +70	560	18~50	10	0.8	30	30
PGM2004-PP	500	500	-30 ~ +70	560	45~150	20	0.8	30	30
PGM2005-PP	500	500	-30 ~ +70	560	140~300	20	0.8	30	30

▶ Order Codes

Order Codes (PGM)

PGM5516	P
Part Number	Package

► General Information

General Purpose Resistors with Customized Service

Token Electronics is expanding business to include a broad range of General Purpose Resistor products designed for high volume applications. This expanded range of commercial resistor presents a more comprehensive product offering for Customer Experience Management (CEM) and other high volume customers that require quality products at competitive pricing.

Backed by the same customer service, technical support and quality assurance that Token has always provided, these new commercial products enable you the opportunity to source a wider range of resistors from a trusted supplier.

General Use

When an ambient temperature exceeds a rated ambient temperature, resistor shall be applied on the derating curve by derating the load power. General purpose resistor under overloads is not combustion resistant and is likely to emit, flame, gas, smoke, red heat, etc. Flame retardant resistor generally emits smoke and red heat in a certain power and over but do not emit fire or flame.

When resistors are shielded or coated with resin etc., stress from the storage heat and the resins are applied. So, performance and reliability should be checked well before use.

When a voltage higher than rated is applied in a short time (single pulse, repeated pulses, surge, etc.), it does not necessarily ensure safety that an effective wattage is not higher than a rated wattage. Then consult with us with your specified pulse wave shape. Resistors shall be used in a condition causing no dew condensation.

Keep temperature from rising by choosing resistor with a higher rated capacity; do not use a component having the exact load value required. For considerations of safety in extended period applications, the rating should be more than four times higher than the actual wattage involved, but never use resistors at less than 25% of its rated power.

In applications where resistors are subject to intermittent current surges and spikes, be sure in advance that the components selected are capable of withstanding brief durations of increased load.

Do not exceed the recommended rated load. Resistor must use within the rated voltage range to prevent the shortening of service life and/or failure of the wound resistance elements.

Minimum load: Resistor must be utilized at 1/10 or more of the rated voltage to prevent poor conductance due to oxidation build-up. For basic particulars for cautions, refer to EIAJ Technical Report RCR-2121 "Guidance for care note on fixed-resistors".



Ceramic Housed Cement Resistors (SQ)

► Product Introduction

Low-cost Ceramic Encased Cement Resistors Suit High Volumes and High Temperatures.

Features :

- Low cost, space saving
- RoHS compliant with 100% lead free
- Direct mounting on printed circuit board
- Circuit board lock-in mounting tabs available
- High performance for power required applications
- High power to size ratio, Special inorganic potting compound
- Ceramic case provide high thermal conductivity in a fireproof package

Applications :

- Power supplies
- Voltage dividers
- Motor controllers
- Automotive applications
- Power electronics circuits

Token electronics offers commercial grade ceramic-housed power wire wound and film resistors. For medium to high rated power (2W...50W), SQ resistors provide full electrical insulation mounted in a ceramic case.

Axial, radial, vertical styles and several mounting techniques of wire leads or quick disconnects are available from Token's SQP, SQM, SQZ, and SQH.

The SQ series power resistors feature ideal specifications for high volume and high-temperature applications. Frequently used in power supplies, motor controllers, and automotive applications, these products can be custom tailored to individual needs.

With the extended resistance range and high-temperature rating, the resistors can be specified for operation in harsh environments. The SQ series wire wound resistors feature a resistance range from 0.1Ω to $3K\Omega$, while the SQ series power film resistors have a resistance range of 80Ω to $150K\Omega$.

Standard tolerances for both devices are to $\pm 5\%$, with TCRs of $\pm 300\text{ppm}/^\circ\text{C}$ and above. Token is equipped to design and produce custom components to meet many design and reliability demands. Contact us with your specific needs. For more information, please link to Token official website "[General Purpose Resistors](#)".



▶ SQP Dim.

Dimensions (SQP)

Type	Dimension (mm)				Resistance Range (Ω)	
SQP	W \pm 1	H \pm 1	L \pm 1.5	d \pm 0.05	SQP	RS+SQP
2W	7	7	18	0.5~0.6	0.1~82	
3W	8	8	22	0.7~0.8	0.1~180	181~33K
5W	10	9	22	0.7~0.8	0.1~180	181~50K
7W	10	9	35	0.7~0.8	0.1~430	431~50K
10W	10	9	48	0.7~0.8	0.1~470	471~50K
15W	12.5	11.5	48	0.7~0.8	0.5~600	601~150K
20W-25W	14	13.5	60	0.7~0.8	0.8~1K	1.1~150K

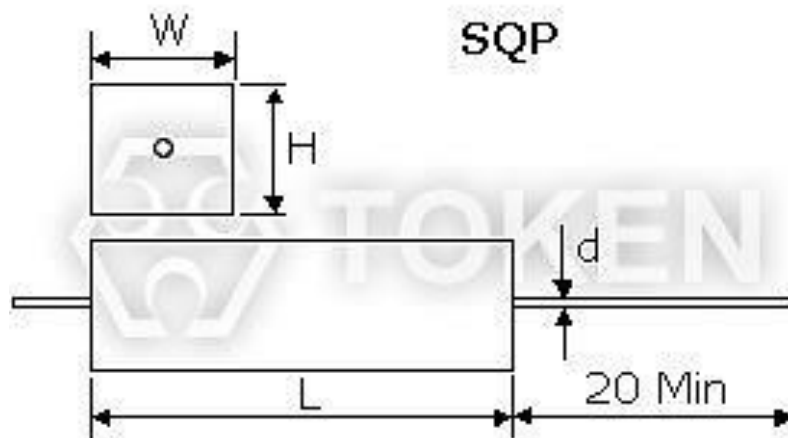

Cement Ceramic Housed (SQP) Dimensions

► SQM Dim.

Dimensions (SQM)

Type	Dimension (mm)			Resistance Range (Ω)	
SQM	H \pm 1.5	W \pm 1	S \pm 1	SQM	RS+SQM
2W	20	12	8	0.1-8.0	81-50K
3W	25	12	8	0.1-180	181-50K
5W	25	13	9	0.1-180	181-50K
7W	39	13	9	0.1-430	431-47K
10W	51	13	12	0.1-470	471-47K
10WS	35	16	12	0.1-430	431-47K

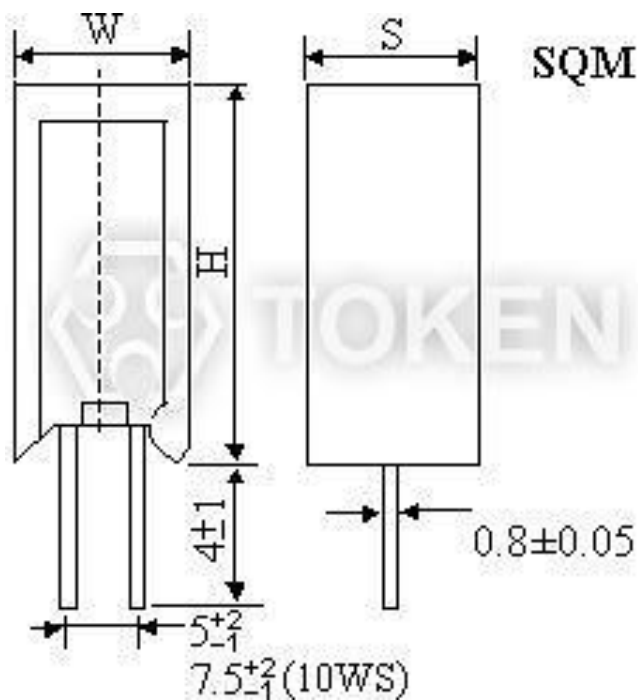

Ceramic Housed (SQM) Dimensions

SQT Dim.

Dimensions (SQT)

Type	Dimension (mm)				Resistance Range (Ω)		
	SQT	H \pm 1.5	W \pm 1	L \pm 1	t \pm 1	SQT	RS+SQM
3W		9	10	22	1.5	0.1-180	181-50K
5W		9	10	22	1.5	0.1-180	181-50K
7W		9	10	35	3.0	0.1-430	431-47K
10W		9	10	48	3.0	0.1-470	471-47K

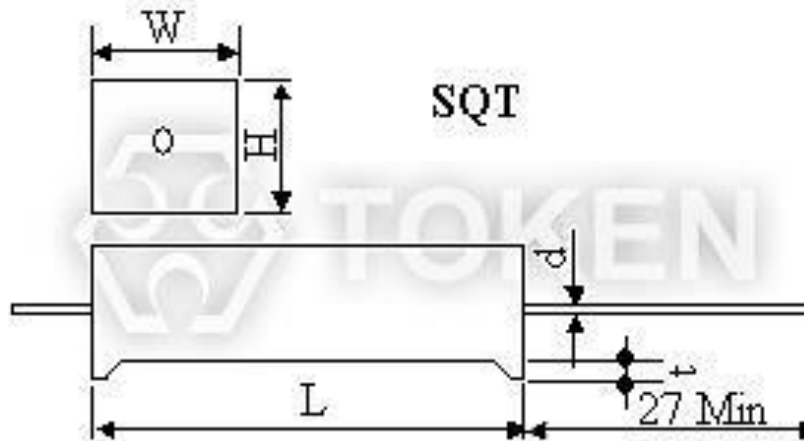

Cement Ceramic Encased (SQT) Dimensions

SQH Dim.

Dimensions (SQH)

Type	Dimension (mm)								Resistance Range (Ω)		Max Working Voltage
	SQH	$W \pm 1$	$H \pm 1$	$L \pm 1.5$	$P \pm 1$	$H_1 \pm 1$	$D \pm 0.5$	$P_1 \pm 0.2$	$P_2 \pm 0.2$	SQH	
10W	10	9	48	32	21	5	2.5	2	0.1~500	500~50K	500V
15W	12.5	11.5	48	32	21	5	2.5	2	1~1K	1K~150K	600V
20W	14.5	13.5	60	43	24	6	3.0	2.5	1~2K	2K~150K	700V
30W	19	19	75	56	29	6	3.0	2.5	1~2K		700V
40W	19	19	90	67	29	6	3.0	2.5	2~3K		700V
50W	19	19	90	67	29	6	3.0	2.5	2~3K		700V

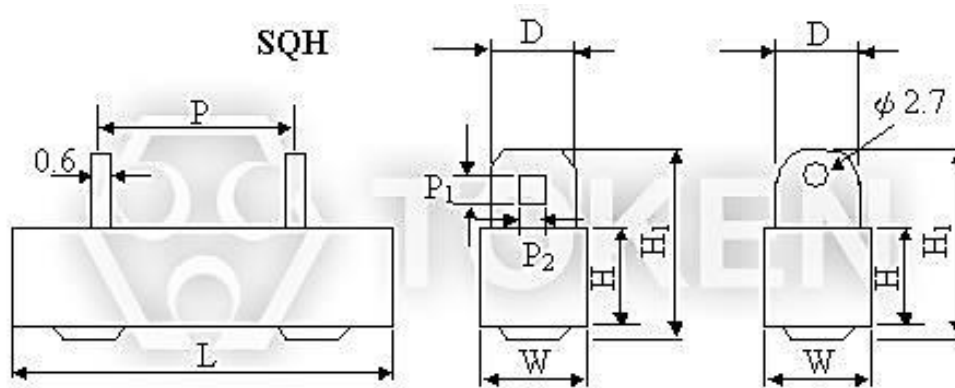

Cement Ceramic Encased (SQH) Dimensions

SQZ Dim.

Dimensions (SQZ)

Type	Dimension (mm)										Resistance Range (Ω)	
SQZ	$L \pm 1.5$	$W \pm 1$	$H \pm 1$	$P \pm 1.5$	P1	P2	P3	P4	$H1 \pm 1$	$H2 \pm 1$	SQZ	RS+SQZ
5W	25(28)	10	10	9.5(15)	4.2	2	5	1.5	25	10.5	0.1-130	131-50K
7W	36	10	10	20	4.2	2	5	1.5	25	10.5	0.1-430	431-50K
10W	48	10	10	32	4.2	2	5	1.5	25	10.5	0.2-470	471-50K
15W	48	12.5	12	32	4.2	2	5	1.5	26	10.5	1-600	601-150K
20.25W	60	15	13	42	7	6	10	2.7	36	15.0	1-1K	1.1K-150K

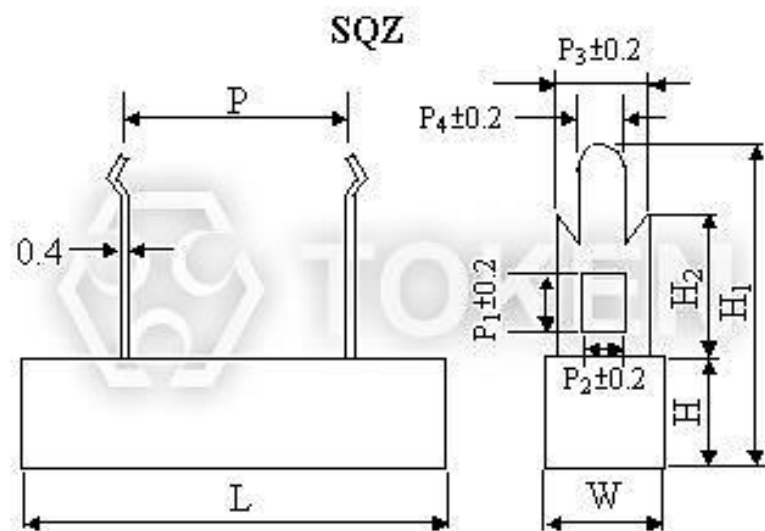

Cement Ceramic Encased (SQZ) Dimensions

► Electrical Performance

Electrical Performance (SQ)

TEST ITEMS	CONDITION	SPEC.
Resistance Temp Coeff.	-30°C ~ 200°C	±300ppm / °C
Short Time Over Load	2.5 times of rated wattage for 5 sec.	±2 %
Rated Load	Rated wattage for 30 min.	±1 %
Voltage Withstanding	800 v AC 1 min.	no charge
Temp. Cycle	-30°C ~ 85°C for 5 cycles	±1 %
Load Life	70°C on-off cycle 1000hrs.	±5 %
Moisture-proof Load Life	40°C 95% RH on-off cycle 500 hrs.	±5 %
Incombustibility	16 times of rated wattage for 5 min.	not flamed

► Material Specifications

Material Specifications (SQ)

- **Core :**
High purity grade alumina ceramic rod.
- **Terminals :**
Tin/lead plated (Lead (Pb)-free will be 100 % tin).
- **Body :**
Steatite ceramic case with inorganic potting compound.
- **Element :**
Copper-nickel alloy, nickel-chrome alloy, resistive wirewound or power film depending on resistance value.

► Order Codes

Order Codes (SQ)

SQP	5W	100R	J	Bulk	
Part Number	Rated Power (W)	Resistance Value (Ω)		Resistance Tolerance (%)	Package
SQP		0R1	0.1Ω	J ±5%	
SQM		100R	100Ω		
SQT		1K	1KΩ		
SQH		100K	100KΩ		
SQZ					

► General Information

General Purpose Resistors with Customized Service

Token Electronics is expanding business to include a broad range of General Purpose Resistor products designed for high volume applications. This expanded range of commercial resistor presents a more comprehensive product offering for Customer Experience Management (CEM) and other high volume customers that require quality products at competitive pricing.

Backed by the same customer service, technical support and quality assurance that Token has always provided, these new commercial products enable you the opportunity to source a wider range of resistors from a trusted supplier.

General Use

When an ambient temperature exceeds a rated ambient temperature, resistor shall be applied on the derating curve by derating the load power. General purpose resistor under overloads is not combustion resistant and is likely to emit, flame, gas, smoke, red heat, etc. Flame retardant resistor generally emits smoke and red heat in a certain power and over but do not emit fire or flame.

When resistors are shielded or coated with resin etc., stress from the storage heat and the resins are applied. So, performance and reliability should be checked well before use.

When a voltage higher than rated is applied in a short time (single pulse, repeated pulses, surge, etc.), it does not necessarily ensure safety that an effective wattage is not higher than a rated wattage. Then consult with us with your specified pulse wave shape. Resistors shall be used in a condition causing no dew condensation.

Keep temperature from rising by choosing resistor with a higher rated capacity; do not use a component having the exact load value required. For considerations of safety in extended period applications, the rating should be more than four times higher than the actual wattage involved, but never use resistors at less than 25% of its rated power.

In applications where resistors are subject to intermittent current surges and spikes, be sure in advance that the components selected are capable of withstanding brief durations of increased load.

Do not exceed the recommended rated load. Resistor must use within the rated voltage range to prevent the shortening of service life and/or failure of the wound resistance elements.

Minimum load: Resistor must be utilized at 1/10 or more of the rated voltage to prevent poor conductance due to oxidation build-up. For basic particulars for cautions, refer to EIAJ Technical Report RCR-2121 "Guidance for care note on fixed-resistors".



Carbon Composition Resistors (CCR)

▶ Product Introduction

High pulse withstanding carbon composition resistors handle big peaks and pulses.

Features :

- Low inductance
- Solid rod carbon composition
- Power rating 1/4W and 2W
- Resistance range 1.8Ω ~ 22KΩ
- Resistance tolerance J(±5%), K(±10%) and M(±20%)
- High pulse withstanding and high energy capability
- Products with Pb-free Terminations and RoHS compliant

Applications :

- Strobe Lighting
- High Power Lighting
- Medical defibrillators
- Welding, Automotive
- Inrush Current Limiting
- High Voltage Power Supplies
- Protection (e.g. Discharge Circuits, Surge Protection)

The high pulse withstanding capability of the CCR series of carbon composition resistors from Token Electronics offers designers a compact solution for applications involving high voltages and high-energy pulses.

Though, many resistor manufacturers claim to offer carbon composition replacements. However, these wire wound or thick film alternatives do not fully match the pulse performance and low inductance of carbon composition.

Token's CCR series now offers the industry a carbon composition resistor made up of a solid rod of conductive composite material, the chemical composition of which is altered to produce different resistance values.

The main advantage of carbon composition is their pulse handling capability. This is due to the fact that the entire rod conducts and so the thermal mass is far higher, which results in a higher energy capability. Due to the need for higher peak voltages, the CCR range is perfect for vehicle ignition system applications, medical monitoring equipment and as output resistors in defibrillators.

The standard carbon composition CCR resistor offers a power rating of 1/4W, 1/2W, 1W and 2W at 25 °C and is made up of a solid rod of conductive composition material, which can be altered to produce different resistance values. With a typical resistance range of 1.8Ω ~ 22KΩ, resistance tolerance is J(±5%), K(±10%) and M(±20%). Resistors with 5%, 10% and 20% tolerance have four bands indicating value and tolerance in accordance with IEC62.

Our custom solutions are designed to address your need for technical and economic success in a timely manner. Contact us with your specific needs. For more information, please link to Token official website "[General Purpose Resistors](http://www.token.com.tw)".



► Dimensions

Dimensions (Unit: mm) (CCR)

Type	Power Rating	L		ΦD	H	Φd
CCR	1/4W	6.3	+1.0	2.3±0.3	27±2	0.60±0.02
			-1.0			
CCR	1/2W	9.5	+0.5	3.5±0.3	27±2	0.70±0.02
			-1.5			
CCR	1W	15	+1.5	6.0±0.3	28±2	0.80±0.02
			-0.5			
CCR	2W	18	+0.5	8.0±0.3	27±2	1.00±0.02
			-1.5			

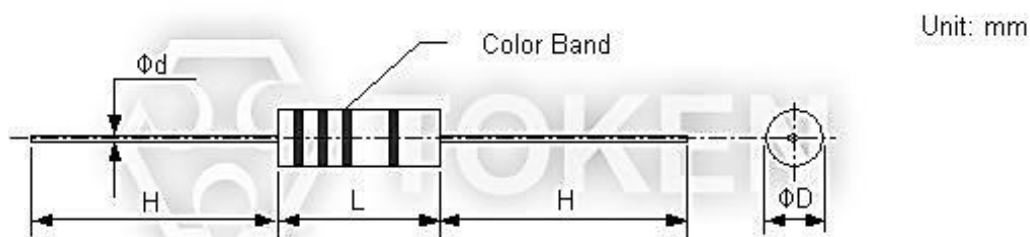

Carbon Composition (CCR) Dimensions (Unit: mm)

► Ratings Specifications

Ratings Specifications (CCR)

Type	Power Rating	Resistance Range	Tolerance E12,E24	Max Working voltage	Max overload Voltage	Rated Ambient Temp.	Operating Temp. Range
CCR	1/4W	2.2Ω ~ 12MΩ	J(±5%) K±10% M±20%	250V	400V	+70°C	-55°C ~ +125°C
CCR	1/2W	2.2Ω ~ 22MΩ		350V	700V	+70°C	-55°C ~ +125°C
CCR	1W	2.2Ω ~ 22KΩ		500V	1000V	+70°C	-55°C ~ +125°C
CCR	2W	1.8Ω ~ 10KΩ		500V	1000V	+70°C	-55°C ~ +125°C

- Rated Voltage = $\sqrt{\text{Power Rating} \times \text{Resistance Value}}$ or Max. Working voltage, whichever is lower.

▶ Derating Curve

| Derating Curve (CCR)

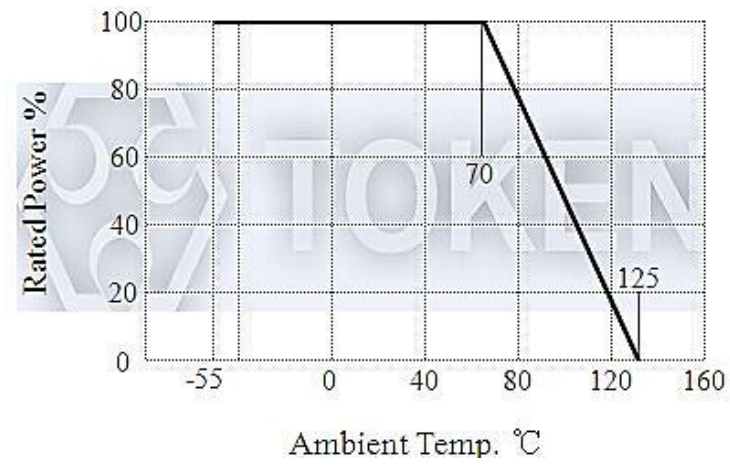

(CCR) Derating Curve

Performance

Performance (CCR)

Description		Performance Requirements		Test Method
Resistance Temperature Coefficient	Resistance Range	Maximum Resistance Value Change %		Test Temperature +20°C /-40°C /+20°C /+100°C /+20°C
		-40~+20°C	+20~+100°C	
	<1KΩ	±6.5%	±5.0%	
	1.1KΩ ~10KΩ	±10%	±6.0%	
	11KΩ ~100KΩ	±13%	±7.5%	
	11KΩ ~1MΩ	±15%	±10%	
	1.1MΩ ~10MΩ	±20%	±15%	
	>11MΩ	±25%	±20%	
Short-time Overload		ΔR≤±2.5%		Rate Voltage*2.5 or maximum overload voltage (the lower)5sec.
With Standing Voltage		No flashover or breakdown		2times maximum working voltage 1 minute
Terminal Strength	Pulled	ΔR≤±2% No visible damage		Load 10N 10s
	Winded			Load 10N 4*90°
	Twisted			3*360° in opposite direction
Resistance to vibration		No visible damage		10~50Hz 3 direction 2 hours each
Solder-heat Resistance		ΔR≤±5% Marks legible, no visible damage		350°C 4mm from the body,3 seconds
Solderability		At least 95% if the dipping surface must be covered by new solder, no flaws gathered.		235°C 2mm from the body,2 seconds
Temperature Cycle		ΔR≤±2% No visible damage		-40°C (30min.)/85°C (30min.)5 cycles
Humidity		ΔR≤±10% No visible damage		40°C 95% RH 240 hours
Load Life		ΔR≤±10% No visible damage, marks legible		Rated voltage or maximum working voltage, 1.5 hours on, 0.5 hours off, 40°C 1000 hours

Order Codes

Order Codes (CCR)

CCR	1/2W	120R		K	P		
Part Number	Rated Power (W)	Resistance Value (Ω)		Resistance Tolerance (%)		Package	
CCR		2R2	2.2Ω	J	±5%	P	Bulk
		120R	120Ω	K	±10%		
		1M2	1.2MΩ	M	±20		
		22M	22MΩ				

► General Information

General Purpose Resistors with Customized Service

Token Electronics is expanding business to include a broad range of General Purpose Resistor products designed for high volume applications. This expanded range of commercial resistor presents a more comprehensive product offering for Customer Experience Management (CEM) and other high volume customers that require quality products at competitive pricing.

Backed by the same customer service, technical support and quality assurance that Token has always provided, these new commercial products enable you the opportunity to source a wider range of resistors from a trusted supplier.

General Use

When an ambient temperature exceeds a rated ambient temperature, resistor shall be applied on the derating curve by derating the load power. General purpose resistor under overloads is not combustion resistant and is likely to emit, flame, gas, smoke, red heat, etc. Flame retardant resistor generally emits smoke and red heat in a certain power and over but do not emit fire or flame.

When resistors are shielded or coated with resin etc., stress from the storage heat and the resins are applied. So, performance and reliability should be checked well before use.

When a voltage higher than rated is applied in a short time (single pulse, repeated pulses, surge, etc.), it does not necessarily ensure safety that an effective wattage is not higher than a rated wattage. Then consult with us with your specified pulse wave shape. Resistors shall be used in a condition causing no dew condensation.

Keep temperature from rising by choosing resistor with a higher rated capacity; do not use a component having the exact load value required. For considerations of safety in extended period applications, the rating should be more than four times higher than the actual wattage involved, but never use resistors at less than 25% of its rated power.

In applications where resistors are subject to intermittent current surges and spikes, be sure in advance that the components selected are capable of withstanding brief durations of increased load.

Do not exceed the recommended rated load. Resistor must use within the rated voltage range to prevent the shortening of service life and/or failure of the wound resistance elements.

Minimum load: Resistor must be utilized at 1/10 or more of the rated voltage to prevent poor conductance due to oxidation build-up. For basic particulars for cautions, refer to EIAJ Technical Report RCR-2121 "Guidance for care note on fixed-resistors".



Fusible Resistors (FRN, FKN, FSQ)

► Product Introduction

||| Fusible resistor features best of both worlds.

Features :

- Low Cost
- Low Noise
- Reduced numbers of parts used in circuits
- Products with Pb-free Terminations and RoHS compliant

Applications :

- Telecommunications
- Household appliances
- Inrush Pulse protection
- Lightning strike protection
- Input protection for small power supplies and battery chargers

Designers of small power supplies and battery chargers for consumer products can benefit from a fusible resistor with superior lightning strike and pulse abilities in a cost effective package.

Token Electronics offers a combination resistor/fuses series of metal/carbon film fusible resistor (FRN), wire wound fuse resistor (FKN) and cement encased fusing resistors (FSQ). Token offers fusible FRN series a low-cost alternative to traditional solutions for applications that require surge protection.



The robust ceramic encased cement resistor (FSQ) and wire wound resistor (FKN) are ideal for power supply applications across the telecoms, military and industrial markets which require a replacement for carbon composition resistors within the circuit design.

As part of the Token input protection range, this resistor provides a key fusible solution and is completely customizable to suit the individual application design requirements. Key design engineers with a need for a robust resistor, will find the FRN, FKN and FSQ series are a multifaceted product, providing comparable pulse performance with added fusing capabilities.

Our custom solutions are designed to address your need for technical and economic success in a timely manner. Contact us with your specific needs. Or link to Token official website "[General Purpose Resistors](http://www.token.com.tw)" for more information.



► Specifications (FRN)

Specifications & Dimensions (Unit: mm) Thin-Film Fusible Resistor (FRN)

Type	Rated Wattage	Dimension (mm)				Resistance Range	Dielectric Withstanding Voltage
		$L \pm 1.5$	$D \pm 1$	$H \pm 3$	$d \pm 0.05$		
FRN	1/4W	6	2.3	26	0.40~0.50	0.22Ω~100KΩ	300V
	1/2W	6	2.3	26	0.50~0.55	0.22Ω~100KΩ	300V
	1W	9	3.0	26	0.50~0.55	0.22Ω~100KΩ	350V
	2W	11	4.0	26	0.75~0.80	0.3Ω~100KΩ	500V
	3W	15	5.0	35	0.75~0.80	0.3Ω~100KΩ	500V

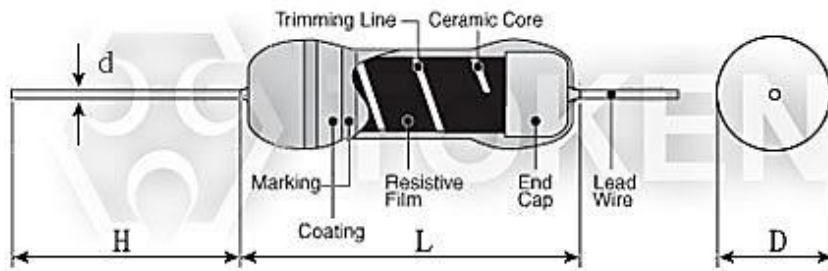

Thin-Film Fusible Resistor (FRN) Dimensions (Unit: mm)

► Specifications (FKN)

Specifications & Dimensions (Unit: mm) Wire wound Fuse Resistor (FKN)

Type	Rated Wattage	Dimension (mm)				Resistance Range	Dielectric Withstanding Voltage
		$L \pm 1.5$	$D \pm 1$	$H \pm 3$	$d \pm 0.05$		
FKN	1W	9	4.5	26	0.50~0.55	0.1Ω~22Ω	500V
	2W	11	5.0	26	0.75~0.80	0.1Ω~60Ω	500V
	3W	15	5.5	35	0.75~0.80	0.1Ω~100Ω	500V
	5W	17	6.5	35	0.75~0.80	0.2Ω~200Ω	500V
	6W	24	8.5	38	0.75~0.80	0.3Ω~250Ω	500V

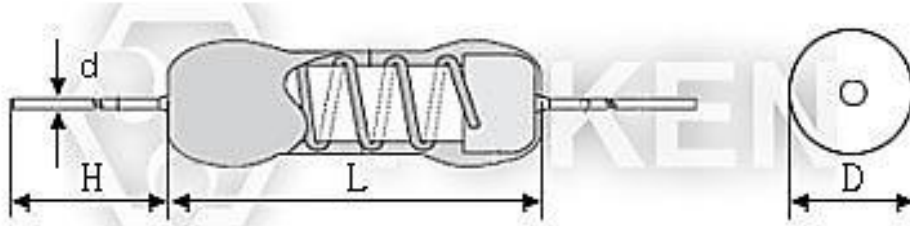

Wirewound Fuse Resistor (FKN) Dimensions (Unit: mm)

► Specifications (FSQ)

Specifications & Dimensions (Unit: mm) Cement Fusing Resistor (FSQ)

Type	Rated Wattage	Dimension (mm)					Resistance Range	Dielectric Withstanding Voltage
		$L \pm 1.5$	$H \pm 0.5$	$W \pm 0.5$	$H \pm 3$	$d \pm 0.05$		
FSQ	2W	18	7	7	35	0.50~0.55	0.1Ω~22Ω	1000V
	3W	22	8	8	35	0.75~0.80	0.1Ω~120Ω	1000V
	5W	22	9	10	35	0.75~0.80	0.2Ω~120Ω	1000V
	7W	35	9	10	35	0.75~0.80	0.3Ω~250Ω	1000V
	10W	48	9	10	35	0.75~0.80	0.3Ω~500Ω	1000V

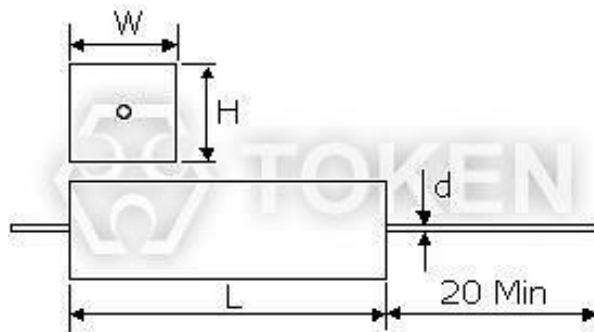

Ceramic Encased Cement Fusing Resistor (FSQ) Dimensions (Unit: mm)

► Characteristics

Electrical Characteristics (FRN, FKN, FSQ)

Test Items	Condition	Spec.
Operating Temp.	-30°C ~155°C	
Resistance Temp. Coeff.	-30°C ~150°C	± 200PPM / °C
Short Time Overload	2 times of rated voltage for 5 sec.	± 2 %
Temp. Cycle	-30°C ~85°C for 5 cycles	± 1 %
Load Life	25°C on-off cycle 1,000 hrs.	± 5 %
Moisture-Proof Load Life	40°C 95°C RH on-off cycle 1,000 hrs.	± 5 %
Solder Pot	270°C for 3 sec.	± 1 %
Incombustibility	16 times of rated wattage for 5 min.	not flamed

Fusing Characteristics (FRN, FKN, FSQ)

POWER WATTAGE	FUSING TIME
16 × Rated Wattage	Within 2 min
24 × Rated Wattage	Within 1 min
32 × Rated Wattage	Within 30 sec.



▶ Application Notes

Application Notes of Fusible Resistors (FRN, FKN, FSQ)

For fusible resistors, unlike fuses, fusing performance is given in terms of power rather than current. The power can be calculated:

$$\text{Power} = \text{Amperes}^2 \times \text{Ohms}$$

Fusing Device Application Notes

- When using, it shall be made sure that the overload conditions at unusual moments lie within the fusing territory.
- Consult with Token in advance when overloaded higher than the rated voltage under an ordinary situation since such an overload may store up damages on resistors.
- Use at the maximum open-circuit voltage or lower as an arc phenomenon may arise when high voltage is applied again after fusing by an over current.
- Consult with us for the maximum open- circuit voltage because it varies with applications.

▶ Order Codes

Order Codes (FRN, FKN, FSQ)

FRN	1/2W	0.47R		J	TB	
Part Number	Rated Power (W)	Resistance Value (Ω)		Resistance Tolerance (%)	Package	
FRN		R47	0.47Ω	J	P	Bulk
FKN		47R	47Ω		TB	Taping B x
FSQ		470R	470Ω			
		4K7	4.7KΩ			
		47K	47KΩ			



▶ General Information

General Purpose Resistors with Customized Service

Token Electronics is expanding business to include a broad range of General Purpose Resistor products designed for high volume applications. This expanded range of commercial resistor presents a more comprehensive product offering for Customer Experience Management (CEM) and other high volume customers that require quality products at competitive pricing.

Backed by the same customer service, technical support and quality assurance that Token has always provided, these new commercial products enable you the opportunity to source a wider range of resistors from a trusted supplier.

General Use

When an ambient temperature exceeds a rated ambient temperature, resistor shall be applied on the derating curve by derating the load power. General purpose resistor under overloads is not combustion resistant and is likely to emit, flame, gas, smoke, red heat, etc. Flame retardant resistor generally emits smoke and red heat in a certain power and over but do not emit fire or flame.

When resistors are shielded or coated with resin etc., stress from the storage heat and the resins are applied. So, performance and reliability should be checked well before use.

When a voltage higher than rated is applied in a short time (single pulse, repeated pulses, surge, etc.), it does not necessarily ensure safety that an effective wattage is not higher than a rated wattage. Then consult with us with your specified pulse wave shape. Resistors shall be used in a condition causing no dew condensation.

Keep temperature from rising by choosing resistor with a higher rated capacity; do not use a component having the exact load value required. For considerations of safety in extended period applications, the rating should be more than four times higher than the actual wattage involved, but never use resistors at less than 25% of its rated power.

In applications where resistors are subject to intermittent current surges and spikes, be sure in advance that the components selected are capable of withstanding brief durations of increased load.

Do not exceed the recommended rated load. Resistor must use within the rated voltage range to prevent the shortening of service life and/or failure of the wound resistance elements.

Minimum load: Resistor must be utilized at 1/10 or more of the rated voltage to prevent poor conductance due to oxidation build-up. For basic particulars for cautions, refer to EIAJ Technical Report RCR-2121 "Guidance for care note on fixed-resistors".



Metal Oxide Resistors (RSS, RSN)

► Product Introduction

Metal Oxide Resistors on the pulse in various forming styles for different applications.

Features :

- Tolerances: G ($\pm 2\%$), J ($\pm 5\%$)
- Lead (Pb)-free and RoHS compliant
- Power wattages up to 10W at + 25 °C
- Operating temperature range: -55°C ~200°C
- Axial leaded type, high power at compact sizes
- Replace carbon composition components in some applications

Applications :

- Ballasts
- Amplifiers
- Power supplies
- Telecommunications
- Household appliances
- Automotive, Computer, Instrumentation

Now available from Token Electronics is a new range of highly stable and reliable metal oxide resistors providing high power in a small package with various forming styles and different leads for different applications.

New RS series resistors are ideal for pulse applications in adverse conditions and are available in different sizes with power ratings of 0.5W to 10W for a power voltage range from 200V to 850V. Highly temperature resistant the devices feature a resistance range from 10 Ω to 47K Ω .

RS series resistors are available in various forming styles and different leads for different applications like power supplies, amplifiers, household appliances and ballasts.

Manufactured by depositing a homogeneous oxide film of metal alloy onto a high-grade ceramic body, the metal oxide resistors are coated with a nonflammable lacquer providing mechanical, electrical and climatic protection.

The devices come packaged in ammo pack boxed or tape and reel format. All RS Series devices are RoHS-compliant, and compatible with high temperature soldering processes normally employed for lead free solders.

Contact us with your specific needs. For more information, please link to Token official website "[General Purpose Resistors](http://www.token.com.tw)".



Specifications & Dimensions

Specifications & Dimensions (Unit: mm) (RSS, RSN)

Type		Dimensions (Unit: mm)				Resistance Range	Tolerance E24	MAX Working Voltage		Dielectric Withstanding Voltage	
RSS	RSN	L	D	H	$d \pm 0.05$	(Ω)	(%)	RSS	RSN	RSS	RSN
1/2W	1/4W	6.0 \pm 0.3	2.3 \pm 0.3	26 \pm 1	0.40~0.50	10 Ω ~ 22K Ω	\pm 2%, \pm 5%	200V	300V	400V	500V
1W	1/2W	9.0 \pm 0.5	3.0 \pm 0.5	26 \pm 1	0.50~0.55	10 Ω ~ 33K Ω	\pm 2%, \pm 5%	250V	350V	500V	600V
2W	1W	11 \pm 1.0	4.0 \pm 0.5	26 \pm 3	0.75~0.80	10 Ω ~ 47K Ω	\pm 2%, \pm 5%	300V	350V	600V	700V
3W	2W	15 \pm 1.0	5.0 \pm 0.5	35 \pm 3	0.75~0.80	10 Ω ~ 47K Ω	\pm 2%, \pm 5%	350V	350V	700V	700V
5W	3W	17 \pm 1.0	6.0 \pm 0.5	35 \pm 3	0.75~0.80	10 Ω ~ 47K Ω	\pm 2%, \pm 5%	350V	500V	700V	1000V
-	5W	24 \pm 1.0	8.0 \pm 0.5	38 \pm 3	0.75~0.80	10 Ω ~ 47K Ω	\pm 2%, \pm 5%	500V	700V	800V	1000V
7W	6W	24 \pm 1.0	8.0 \pm 0.5	38 \pm 3	0.75~0.80	10 Ω ~ 47K Ω	\pm 2%, \pm 5%	500V	700V	800V	1000V
10W	7W	41 \pm 1.0	8.0 \pm 0.5	38 \pm 3	0.75~0.80	10 Ω ~ 47K Ω	\pm 2%, \pm 5%	750V	850V	850V	1000V
	10W	53 \pm 1.0	8.0 \pm 0.5	38 \pm 3	0.75~0.80	10 Ω ~ 47K Ω	\pm 2%, \pm 5%	750V	850V	850V	1000V

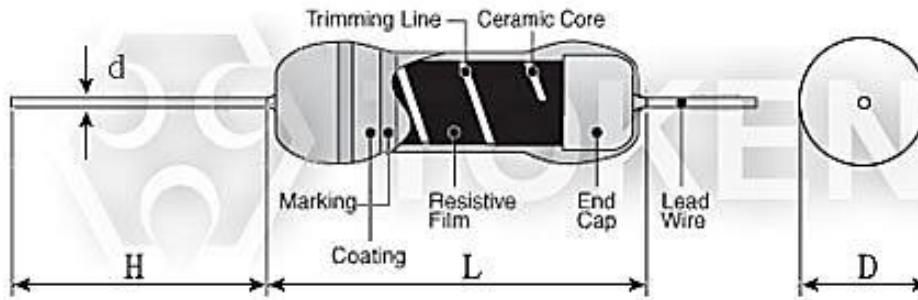

Metal Oxide Film (RSS, RSN) Dimensions (Unit: mm)

► Electrical Performance

Electrical Performance (RSS, RSN)

Requirements		Characteristics	Test Method	
			JIS C 5202	MIL-R-22684B
Operating Temp.Range		-55°C ~200°C		
Temp.Coefficient (ppm/°C)		± 300	5.2	4.6.11
Max. Resistance Changes	Short Time Overload	± (1%+0.05Ω)	5.2A	4.6.5
	Effect of Soldering	± (1%+0.05Ω)	6.4 350°C 2Sec	4.6.9
	Temp.Cycling	± (1%+0.05Ω)	7.4-55°C / 85°C	4.6.3
	Moisture Resistance	± 5%	7.9 1,000hr	4.6.10
	Load Life	± 5%	7.10 1,000hr	4.6.12
Dielectric Withstanding Voltage		± (0.5%+0.05Ω)	5.7A	4.6.7
Non-Combustibility		The resistor shall withstand Overload test in accordance with Artice UL492.2 13 without producing a fire hazard.		
Resistance to Solvents		No damage on the appearance, co. or bands.		

► Application Notes

Non-flammable Resistor Application Notes (RSS, RSN)

- Never use organic solvents to clean non-flammable resistors.
- Maintaining a surface temperature of 200°C or less will extend resistors service life.
- Although the hardness exceeds that of a 3H pencil lead, do not nick the coating with screwdrivers or other pointed objects.
- Smoke emitted from non-flammable resistors on initial use in powered circuits is a normal phenomenon and the component can be safely utilized.
- Non-flammable resistors cannot be utilized in oil. Non-flammable resistors cannot be used in high frequency machinery because of the inductance produced by the grooving.
- Avoid touching non-flammable resistors in operation; the surface temperature ranges from approximately 350 °C to 400°C when utilized at the full rated value.
- All metal oxide film resistors (RSS, RSN) manufactured by Token Electronics Co., Ltd. comply with the U.S. UL-94 non-flammability test, Class V-0, a continuous combustion period of zero seconds.
- Less resistant against external shocks than ordinary resistors due to special flame retardant coating. So, never give shocks or vibrations on the resistors. Also never damage them by picking up the coated films with pliers, tweezers, etc.
- After cleaning, no external power should be put on the coated films before they are well dried.

Order Codes

Order Codes (RSS, RSN)

RSS	0.5W	1KR		J	TB
Part Number	Rated Power (W)	Resistance Value (Ω)		Resistance Tolerance (%)	
RSS		10R	10 Ω	G	$\pm 2\%$
RSN		100R	100 Ω	J	$\pm 5\%$
		1K	1K Ω		
		10K	10K Ω		
					Package
					TB Taping Box

► General Information

General Purpose Resistors with Customized Service

Token Electronics is expanding business to include a broad range of General Purpose Resistor products designed for high volume applications. This expanded range of commercial resistor presents a more comprehensive product offering for Customer Experience Management (CEM) and other high volume customers that require quality products at competitive pricing.

Backed by the same customer service, technical support and quality assurance that Token has always provided, these new commercial products enable you the opportunity to source a wider range of resistors from a trusted supplier.

General Use

When an ambient temperature exceeds a rated ambient temperature, resistor shall be applied on the derating curve by derating the load power. General purpose resistor under overloads is not combustion resistant and is likely to emit, flame, gas, smoke, red heat, etc. Flame retardant resistor generally emits smoke and red heat in a certain power and over but do not emit fire or flame.

When resistors are shielded or coated with resin etc., stress from the storage heat and the resins are applied. So, performance and reliability should be checked well before use.

When a voltage higher than rated is applied in a short time (single pulse, repeated pulses, surge, etc.), it does not necessarily ensure safety that an effective wattage is not higher than a rated wattage. Then consult with us with your specified pulse wave shape. Resistors shall be used in a condition causing no dew condensation.

Keep temperature from rising by choosing resistor with a higher rated capacity; do not use a component having the exact load value required. For considerations of safety in extended period applications, the rating should be more than four times higher than the actual wattage involved, but never use resistors at less than 25% of its rated power.

In applications where resistors are subject to intermittent current surges and spikes, be sure in advance that the components selected are capable of withstanding brief durations of increased load.

Do not exceed the recommended rated load. Resistor must use within the rated voltage range to prevent the shortening of service life and/or failure of the wound resistance elements.

Minimum load: Resistor must be utilized at 1/10 or more of the rated voltage to prevent poor conductance due to oxidation build-up. For basic particulars for cautions, refer to EIAJ Technical Report RCR-2121 "Guidance for care note on fixed-resistors".



Precision Resistors (MF)

► Product Introduction

|| Precision metal-film resistors for low-cost uses.

Features :

- Low cost, low noise, operating temperature range -55°C ~ 155°C
- Precision tight tolerance available in $\pm 0.1\%$, $\pm 0.25\%$, $\pm 0.5\%$, $\pm 1\%$
- Pure tin plating provides compatibility with lead (Pb)-free and lead containing soldering processes

Applications :

- Telecom
- Test and measurement
- All general purpose applications

Token offers a low-cost alternative commercial metal film resistor for precision applications. The MF series offers tight tolerances and low TCRs over a wide resistance range and are suitable for applications where long-term stability is paramount.

The MF is available in a resistance range of 10Ω to $1M\Omega$ with a standard resistance tolerance of $\pm 1\%$ and a temperature coefficient of resistance (TCR) of $+15/-25\text{ppm}/^\circ\text{C}$, although other tolerances and TCRs are available.

The resistance element in these devices is a precisely controlled thin film of metal alloy deposited on a high quality alumina rod. Plated caps are force-fitted before the assembly is trimmed using advanced trimming techniques to ensure excellent performance and low electrical noise.

Leads are welded to the end caps prior to the resistor being coated with epoxy, and color band marking applied. A variety of standard lead forms are available for use where auto-insertion is not available or practical. This gives the advantage of the value being shown, even if the resistor is machine preformed or auto-inserted.

The MF is RoHS compliant with 100% lead free; Contact us with your specific needs. For more information, please link to Token official website "[General Purpose Resistors](http://www.token.com.tw)".



► Dimensions & Specifications

Dimensions & Specifications (Unit: mm) (MF)

STYLE	MIL STYLE	POWER RATING(W)		DIMENSION (mm)				MAX WORKING VOLTAGE		MAX OVERLOAD VOLTAGE	
		RN	RNS	L	D	H	d ± 0.05	RN	RNS	RN	RNS
MF - 12	RN-50	1/8W	1/4W	3.2± 0.2	1.5 ± 0.2	26 ± 1.0	0.40~0.45	200	150	400	300
MF - 25	RN-55	1/4W	1/2W	6.0 ± 0.3	2.3 ± 0.3	26 ± 1.0	0.40~0.50	250	200	500	400
MF - 50	RN-60	1/2W	1W	9.0 ± 0.5	3.0 ± 0.5	26 ± 1.0	0.50~0.55	350	250	700	500
MF - 100	RN-65	1W	2W	11 ± 1.0	4.0 ± 0.5	35 ± 3.0	0.75~0.80	500	300	1000	600
MF - 200	RN-70	2W	3W	15 ± 1.0	5.0 ± 0.5	35 ± 3.0	0.75~0.80	500	350	1000	700

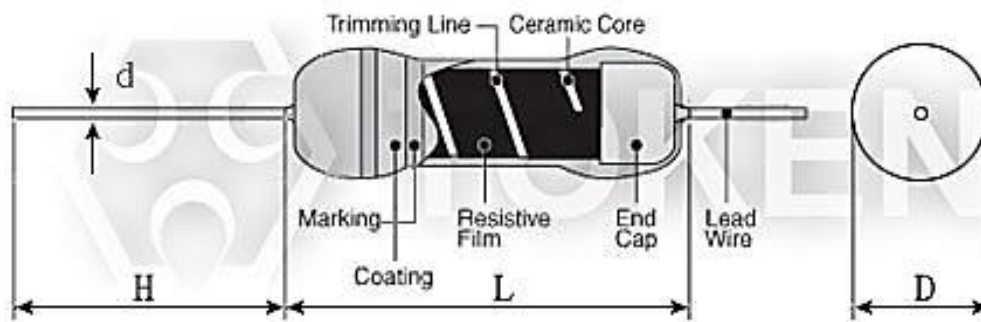

Metal Film Resistors (MF) Dimensions (Unit: mm)

Resistance Range

Resistance Range (MF)

STYLE	MIL STYLE	TOLERANCE	TC+15-25PPM	TC+50PPM	TC+100PPM	REMARK
MF-12	RN-50	±1% ±0.5% ±0.25%	100Ω-100KΩ 100Ω-100KΩ 100Ω-100KΩ	10Ω-1MΩ	10Ω-1MΩ	* Standard resistance is 10Ω-1MΩ, below or over this resistance on request.
MF-25	RN-55	±1% ±0.5% ±0.25% ±0.1%	51.1Ω-511KΩ 51.1Ω-511KΩ 100Ω-300KΩ 100Ω-300KΩ	10Ω-1MΩ	10Ω-1MΩ	
MF-50	RN-60	±1% ±0.5% ±0.25% ±0.1%	51.1Ω-1KΩ 51.1Ω-1KΩ 100Ω-551KΩ 100Ω-330KΩ	10Ω-1MΩ	10Ω-1MΩ	
MF-100	RN-65	±1% ±0.5% ±0.25% ±0.1%	51.1Ω-1KΩ 51.1Ω-1KΩ 100Ω-551KΩ 100Ω-330KΩ	10Ω-1MΩ	10Ω-1MΩ	
MF-200	RN-70	±1% ±0.5% ±0.25% ±0.1%	51.1Ω-1KΩ 51.1Ω-1KΩ 100Ω-551KΩ 100Ω-330KΩ	10Ω-1MΩ	10Ω-1MΩ	

Electrical Performance

Electrical Performance (MF)

REQUIREMENTS	CHARACTERISTICS	JIS C 5202	MIL-R-10509F
Operating Temp. Range	-55°C ~ 155°C		
Temp Coefficient (°C)	±25 ±50 ±100	5.2	4.6.12
Short Time Overload	±(0.5%+0.05Ω)	5.5 A	4.6.6
Dielectric Withstanding V	±(0.5%+0.05Ω)	5.7 A	4.6.8
Effect of Soldering	±(0.5%+0.05Ω)	6.4 350°C 3 sec	4.6.10
Temperature Cycling	±(0.5%+0.05Ω)	7.4	4.6.4
Low Temp Operation	±(0.5%+0.05Ω)		4.6.5
Terminal Strength	±(0.5%+0.05Ω)	6.1	4.6.7
Moisture Resistance	±(1%+0.05Ω)	7.9 1,000hr	MIL R-22684 4.6.10
Load Life	±(1%+0.05Ω)	7.10 1,000hr	4.6.13
Storage	±(0.2%+0.05Ω)	Shelved one year in a room of normal temperature and humidity	

Order Codes

Order Codes (MF)

MF-25	1/4W	100R		F		TB	
Part Number	Rated Power (W)	Resistance Value (Ω)		Resistance Tolerance (%)		Package	
MF		10R	10 Ω	B	$\pm 0.10\%$	P	Bulk
		100R	100 Ω	C	$\pm 0.25\%$	TB	Taping Box
		1K	1K Ω	D	$\pm 0.5\%$		
		1M	1M Ω	F	$\pm 1.0\%$		

▶ General Information

General Purpose Resistors with Customized Service

Token Electronics is expanding business to include a broad range of General Purpose Resistor products designed for high volume applications. This expanded range of commercial resistor presents a more comprehensive product offering for Customer Experience Management (CEM) and other high volume customers that require quality products at competitive pricing.

Backed by the same customer service, technical support and quality assurance that Token has always provided, these new commercial products enable you the opportunity to source a wider range of resistors from a trusted supplier.

General Use

When an ambient temperature exceeds a rated ambient temperature, resistor shall be applied on the derating curve by derating the load power. General purpose resistor under overloads is not combustion resistant and is likely to emit, flame, gas, smoke, red heat, etc. Flame retardant resistor generally emits smoke and red heat in a certain power and over but do not emit fire or flame.

When resistors are shielded or coated with resin etc., stress from the storage heat and the resins are applied. So, performance and reliability should be checked well before use.

When a voltage higher than rated is applied in a short time (single pulse, repeated pulses, surge, etc.), it does not necessarily ensure safety that an effective wattage is not higher than a rated wattage. Then consult with us with your specified pulse wave shape. Resistors shall be used in a condition causing no dew condensation.

Keep temperature from rising by choosing resistor with a higher rated capacity; do not use a component having the exact load value required. For considerations of safety in extended period applications, the rating should be more than four times higher than the actual wattage involved, but never use resistors at less than 25% of its rated power.

In applications where resistors are subject to intermittent current surges and spikes, be sure in advance that the components selected are capable of withstanding brief durations of increased load.

Do not exceed the recommended rated load. Resistor must use within the rated voltage range to prevent the shortening of service life and/or failure of the wound resistance elements.

Minimum load: Resistor must be utilized at 1/10 or more of the rated voltage to prevent poor conductance due to oxidation build-up. For basic particulars for cautions, refer to EIAJ Technical Report RCR-2121 "Guidance for care note on fixed-resistors".



Thermal Cut-offs Resistors (FKU, FRU)

► Product Introduction

Ultimate Protection Thermal Cutoffs For High Power Applications.

Features :

- Miniature size
- Radial leaded form
- Accurate fusing temperature
- Various temperature settings
- Current Rating: Up to 10Amp
- Products with Pb-free Terminations and RoHS compliant
- Economical by combining both function of a thermal fuse and a pulse resistor

Applications :

- Motors - fans, copiers, washing machines, air conditioners, compressors.
- Electronics - TVs, tape recorders, stereos, video recorders, fluorescent lamps, transformers, surge suppressors, computers, telecommunication equipment.
- Appliances - electric blankets, space heaters, stoves, irons, hair dryers, cookers, toaster ovens, clothes dryers, toasters, mixers, microwave ovens, crock pots.

Fast-acting protection device for high-power applications combines thermal fuse element and resistor on a single substrate.

Token offers FKU (Wire wound Resistor + Thermal Cut-offs) and FRU (Metal Oxide Film Resistor + Thermal Cut-offs) two Series, both are a new concept in thermal fuse technology and are designed to protect against over-heating in electrical products.

The two active components, a thermal cutoff is a fusible alloy and a resistor is a voltage divider, both are surrounded by ceramic cement with special resin. Under normal operating temperatures the fusible alloy joins the two lead wires within the body of the cutoff and the power resistor acts as a normal function resistor. When the preset temperature of the cutoff is reached, the fusible alloy melts and with the aid of the special resin, complete cutoff is ensured.

By combining a thermal fuse element and resistor on a single substrate, Token has created a fast-acting ultimate protection device for high power applications up to 10A/250V.

Resistance range of FKU Wire wound Type Thermal Cut-offs is 1Ω~100Ω and FRU Metal Oxide Film Type Thermal Cut-offs is 110Ω~10KΩ. Both standard precision tolerances are J (±5%).

Our custom solutions are designed to address your need for technical and economic success in a timely manner. Contact us with your specific needs. Or link to Token official website "[General Purpose Resistors](http://www.token.com.tw)" for more information.



General Specifications

General Specifications (FKU, FRU)

Type	Dimension (Unit: mm)						
	W ± 1	D ± 1	H ± 1.5	RM+2/-1	h	D1(R terminal)	D2(F terminal)
FKU/FRU-5M	13	9	25	5	4.5±1	0.8±0.1	2A:0.6 ±0.1 10A:1.0 ±0.1
FKU/FRU-7M	13	9	38	5			
FKU/FRU-10M	16	12	35	7.5			

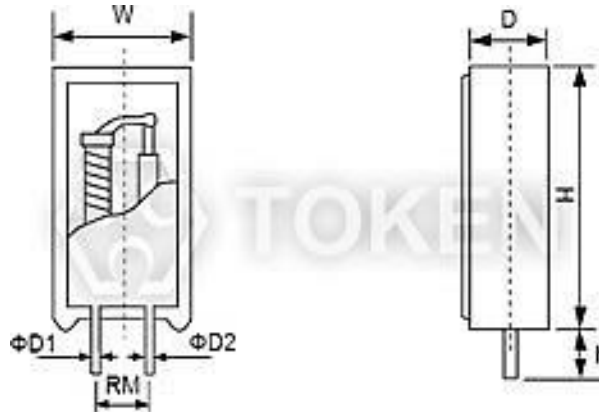

Thermal Cut-offs (FKU/FRU) Dimensions

Power Derating Curve

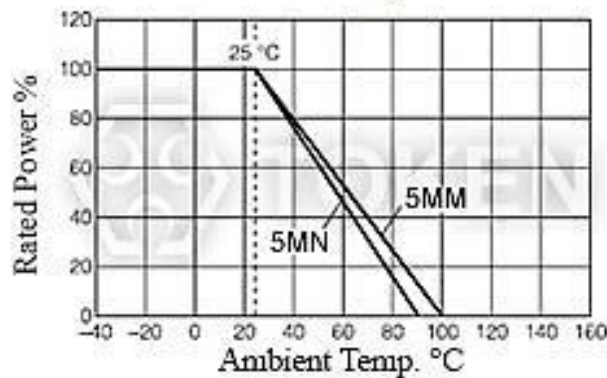

(FKU/FRU) Power Derating Curve

Electrical Performance

Electrical Performance (FKU, FRU)

Fusing Temperature Protector				Rated Power at 25°C (W)			Resistance Range (Ω)		Tolerance (%)	
MARK	Fusing Temperature(°C)	Standard Current(A)	Standard Voltage(V)	5M	7M	10M	FKU	FRU	FKU	FRU
A	109+1/-3	10	250	1.2	1.4	2.0	1~100	110~10K	J(±5) K(±10)	J(±5)
B	129±4			1.6	2.0	2.5				
C	152±4			1.6	2.0	2.5				
D	188+3/-1			2.0	2.4	3.5				
E	226+1/-3			2.0	2.4	3.5				
F	95+3/-0	2		0.8	1.2					
G	110±4			1.2	1.4					
H	126±4			1.4	1.6					
N	130±4			1.6	2.0					
M	145±4			2.1	2.4					

Order Codes

Order Codes (FKU, FRU)

FRU		-	5M	A	10R	K	P
Part Number			Rated Power (W)	Thermal Cut-offs	Resistance Value (Ω)	Resistance Tolerance (%)	Package
FRU	Metal Oxide type Thermal Cut-offs		5M	A 109+1/-3°C	1R 1Ω	J ±5%	P Bulk
			7M	B 129±4°C	10R 10Ω	K ±10%	
			10M	C 152±4°C	100R 100RΩ		
				D 188+3/-1°C	1K 1000Ω		
FKU	Wire wound type Thermal Cut-offs			E 226+1/-3°C			
				F 95+3/-0°C			
				G 110±4°C			
				H 126±4°C			
				N 130±4°C			
				M 145±4°C			

► General Information

General Purpose Resistors with Customized Service

Token Electronics is expanding business to include a broad range of General Purpose Resistor products designed for high volume applications. This expanded range of commercial resistor presents a more comprehensive product offering for Customer Experience Management (CEM) and other high volume customers that require quality products at competitive pricing.

Backed by the same customer service, technical support and quality assurance that Token has always provided, these new commercial products enable you the opportunity to source a wider range of resistors from a trusted supplier.

General Use

When an ambient temperature exceeds a rated ambient temperature, resistor shall be applied on the derating curve by derating the load power. General purpose resistor under overloads is not combustion resistant and is likely to emit, flame, gas, smoke, red heat, etc. Flame retardant resistor generally emits smoke and red heat in a certain power and over but do not emit fire or flame.

When resistors are shielded or coated with resin etc., stress from the storage heat and the resins are applied. So, performance and reliability should be checked well before use.

When a voltage higher than rated is applied in a short time (single pulse, repeated pulses, surge, etc.), it does not necessarily ensure safety that an effective wattage is not higher than a rated wattage. Then consult with us with your specified pulse wave shape. Resistors shall be used in a condition causing no dew condensation.

Keep temperature from rising by choosing resistor with a higher rated capacity; do not use a component having the exact load value required. For considerations of safety in extended period applications, the rating should be more than four times higher than the actual wattage involved, but never use resistors at less than 25% of its rated power.

In applications where resistors are subject to intermittent current surges and spikes, be sure in advance that the components selected are capable of withstanding brief durations of increased load.

Do not exceed the recommended rated load. Resistor must use within the rated voltage range to prevent the shortening of service life and/or failure of the wound resistance elements.

Minimum load: Resistor must be utilized at 1/10 or more of the rated voltage to prevent poor conductance due to oxidation build-up. For basic particulars for cautions, refer to EIAJ Technical Report RCR-2121 "Guidance for care note on fixed-resistors".



Wire wound Resistor (KNP-VE)

▶ Product Introduction

Vitreous Enamel Coated

Power High Energy Wire wound Resistors.

Features :

- Excellent pulse load capability
- Axial leads, All-welded construction
- A wide range of power ratings 2.5W to 12W
- A wide resistance range 1Ω to 39KΩ, Tolerance $\pm 5\%$, $\pm 10\%$
- Products with Pb-free Terminations and RoHS compliant
- Rugged vitreous enamel coating withstands high humidity and temperature cycling
- Durable construction, recommended for industrial applications where reliability is paramount.

Applications :

- Power tools
- Consumer applications
- Power supplies, Welders
- High voltage applications
- High-switching applications
- Home entertainment, appliances

The KNP-VE Series of vitreous enamel coated power resistors from Token offers a cost-competitive alternative over the 2.5W-12W power range. The range is available with resistance values of 1Ω to 39KΩ in power ratings of 2.5W, 3W, 5W, 6W, 8W, 9W and 12W (at 25°C), and with body sizes that match the industry standards.

Vitreous enameled resistors were introduced at a time when alternative directly applied coatings could not withstand the thermal stresses caused by the resistors' high body temperatures.

Token offers the durability of a lead free conformal vitreous enamel coating, permits the KNP-VE Series resistors to maintain a hard coating while operating at high temperatures. Mechanical integrity is enhanced by the all-welded construction.

Power KNP-VE Wire wound Series are ideal for computer, communications and industrial applications in which cost, quality, and reliability are key considerations. The KNP-VE series is RoHS compliant and Ayrton Perry non-inductive windings are available on request.

To address your need for technical and economic success in a timely manner, our custom solutions are the best choice. Contact us with your specific needs. Or link to Token official website "[General Purpose Resistors](http://www.token.com.tw)" for more information.



Technical Specifications

Technical Specifications (KNP-VE)

Type	Rated Watts (W)	Resistance Range (Ω)	Limiting Voltage (V)	Tolerance	Temperature Coefficient (PPM/ $^{\circ}$ C)	Dimensions (mm) (Max)		
						L	Φ D	Φ d
KNP-VE-2.5	2.5	1 ~ 1K	100	$\pm 5\%$ $\pm 10\%$	± 250 ± 400	12.7	5.6	0.8
KNP-VE-3	3	1 ~ 1K	120			14.0	7.0	
KNP-VE-5	5	1 ~ 3.6K	160			23.0	7.0	
KNP-VE-6	6	1 ~ 6.8K	200			22.2	8.0	
KNP-VE-8	8	1 ~ 20K	400			33.9	8.0	
KNP-VE-9	9	1 ~ 27K	500			38.1	8.0	1.0
KNP-VE-12	12	1 ~ 39K	750			53.5	8.0	

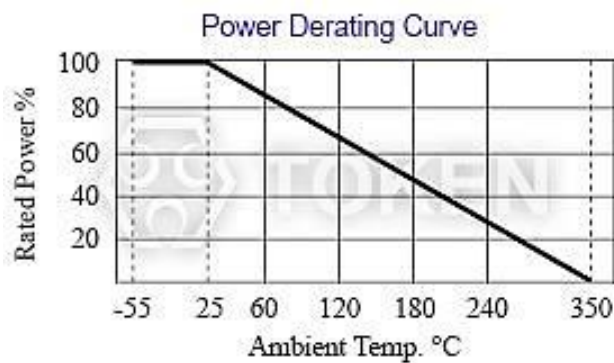

Power (KNP-VE) Derating Curve

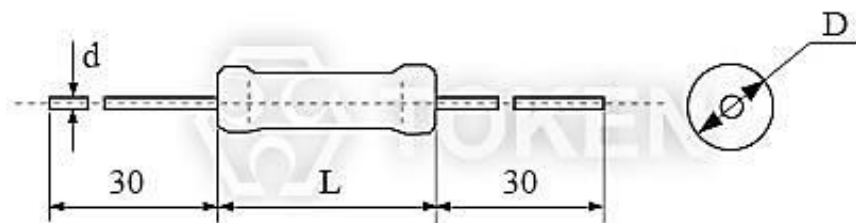

Wire wound Resistors (KNP-VE) Dimensions (Unit: mm)

► Electrical Performance

Electrical Performance (KNP-VE)

Test Items	Condition	Specifications
Insulation Resistance	500V	20MΩ
Short Time Overload	2.5 times of rated voltage 5 sec.	$\Delta R \leq \pm(2\%R + 0.05\Omega)$
Rated Load	Rated wattage 30 min.	$\Delta R \leq \pm(1\%R + 0.05\Omega)$
Dielectric Withstanding Voltage	500V AC 1 min	$\Delta R \leq \pm(1\%R + 0.05\Omega)$
Temp. Cycle	-20°C ~ 85°C 5 cycles	$\Delta R \leq \pm(1\%R + 0.05\Omega)$
Load Life	70°C on ~ off cycle 1000 hrs.	$\Delta R \leq \pm(5\%R + 0.05\Omega)$
Moisture-Proof Load Life	40°C 95% RH on~off cycle 500 hrs.	$\Delta R \leq \pm(3\%R + 0.05\Omega)$
Soldering After Resistance	350°C for 3 sec	$\Delta R \leq \pm(0.5\%R + 0.05\Omega)$
Incombustibility	16 times of rated wattage for 5 min.	Not flamed

► Application Notes

Application Notes of Wire wounds (KNP-VE)

- When being used in AC circuits, some wirewound structures give inductance ingredients or parasitic capacity, so they may cause unusual phenomena such as oscillations etc. Quorum deviations of other components should be carefully taken into account for use.
- Application and Placement: Wire wound resistors use different gauges of wire as resistance elements. Sometimes the gauge is extremely thin (finer than a strand of human hair) and very susceptible to breakage in environments containing salts, ash, dust and corrosives. Avoid utilization in such environments.
- Do not install in dusty areas because the accumulation will cause shorts and poor conductance.

► Order Codes

Order Codes (KNP-VE)

KNP-VE	-	3W	100R	J	P
Part Number		Rated Power (W)	Resistance Value (Ω)	Resistance Tolerance (%)	Package
KNP-VE			1R 1Ω	J ±5%	P Bulk
			100R 100Ω	K ±10%	TB Taping Box
			1K 1000Ω		

► General Information

General Purpose Resistors with Customized Service

Token Electronics is expanding business to include a broad range of General Purpose Resistor products designed for high volume applications. This expanded range of commercial resistor presents a more comprehensive product offering for Customer Experience Management (CEM) and other high volume customers that require quality products at competitive pricing.

Backed by the same customer service, technical support and quality assurance that Token has always provided, these new commercial products enable you the opportunity to source a wider range of resistors from a trusted supplier.

General Use

When an ambient temperature exceeds a rated ambient temperature, resistor shall be applied on the derating curve by derating the load power. General purpose resistor under overloads is not combustion resistant and is likely to emit, flame, gas, smoke, red heat, etc. Flame retardant resistor generally emits smoke and red heat in a certain power and over but do not emit fire or flame.

When resistors are shielded or coated with resin etc., stress from the storage heat and the resins are applied. So, performance and reliability should be checked well before use.

When a voltage higher than rated is applied in a short time (single pulse, repeated pulses, surge, etc.), it does not necessarily ensure safety that an effective wattage is not higher than a rated wattage. Then consult with us with your specified pulse wave shape. Resistors shall be used in a condition causing no dew condensation.

Keep temperature from rising by choosing resistor with a higher rated capacity; do not use a component having the exact load value required. For considerations of safety in extended period applications, the rating should be more than four times higher than the actual wattage involved, but never use resistors at less than 25% of its rated power.

In applications where resistors are subject to intermittent current surges and spikes, be sure in advance that the components selected are capable of withstanding brief durations of increased load.

Do not exceed the recommended rated load. Resistor must use within the rated voltage range to prevent the shortening of service life and/or failure of the wound resistance elements.

Minimum load: Resistor must be utilized at 1/10 or more of the rated voltage to prevent poor conductance due to oxidation build-up. For basic particulars for cautions, refer to EIAJ Technical Report RCR-2121 "Guidance for care note on fixed-resistors".



Wire Wound Resistors (KNP)

▶ Product Introduction

Wire Wound Resistors are Getting Economical Solution to Board Population.

Features :

- Low cost
- Excellent pulse load capability
- A wide resistance range 0.1 Ω to 3 k Ω
- Operating temperature range -55 $^{\circ}$ C ~ 155 $^{\circ}$ C
- A wide range of power ratings 0.5W to 12.5W
- Products with Pb-free Terminations and RoHS compliant.

Applications :

- Ballast
- Power tools
- Consumer applications
- Power supplies, Welders
- High voltage applications
- Home entertainment, appliances

Token has launched its commercial wire wound resistor yet with the introduction of the various package sizes. Matching price with size to provide an economical solution to board population, Token's wire wound resistors are available in 15 standard size powers ranging from 0.5W to 12.5W, all at 1%, 2%, and 5% tolerance.

The KNP series has been designed to give enhanced pulse handling capability and increased flameproof protection. The series is RoHS compliant with Pb-free terminations, and KNP wire-wound series can also be supplied with radial, goalpost or lancet preformed leads.

The KNP drive to miniaturize is as widespread within industrial process control and circuit break products as it is in the consumer sector. These resistors are ideal for high reliability industrial application as the technology removes the excessive temperature risk.

Produced on a high purity ceramic substrate, the resistor is assembled with interference-fit end caps to which are welded terminations. The resistive element is wound on the substrate and welded to the caps. Flameproof silicone cement coating is applied prior to marking with indelible link. The components are then lead formed, if required.

To address your need for technical and economic success in a timely manner, our custom solutions are available. Contact us with your specific needs. For more information, please link to Token official website "[General Purpose Resistors](#)".



General Specifications

General Specifications (KNP)

Type		Rated Watts	Dimensions (mm)				Resistance Range (Ω)	Tolerance
			$D \pm 0.5$	$L \pm 1$	$H \pm 3$	$d \pm 0.05$		
KNP	KNP-50	1/2W	4	9.0	26	0.50~0.55	0.1-50 Ω	± 1% ± 2% ± 5%
	KNP-100	1W	4	9.0	26	0.50~0.55	0.1-50 Ω	
	KNP-100B	1W	4.5	11.5	26	0.75~0.80	0.1-100 Ω	
	KNP-200	2W	4.5	11.5	26	0.75~0.80	0.1-100 Ω	
	KNP-200B	2W	5.5	15.5	35	0.75~0.80	0.1-200 Ω	
	KNP-300	3W	5.5	15.5	35	0.75~0.80	0.1-200 Ω	
	KNP-400	4W	6.5	17.5	35	0.75~0.80	0.1-300 Ω	
	KNP-500	5W	6.5	17.5	35	0.75~0.80	0.1-400 Ω	
	KNP-500B	5W	8.5	24.5	38	0.75~0.80	0.1-400 Ω	
	KNP-600	6W	8.5	24.5	38	0.75~0.80	0.1-1K Ω	
	KNP-700	7W	8.5	24.5	38	0.75~0.80	0.1-1.5K Ω	
	KNP-800	8W	8.5	42	38	0.75~0.80	0.1-2K Ω	
	KNP-1000	10W	8.5	42	38	0.75~0.80	0.1-2K Ω	
	KNP-1000B	10W	8.5	54	38	0.75~0.80	0.1-3K Ω	
	KNP-1250	12.5W	8.5	54	38	0.75~0.80	0.1-3K Ω	

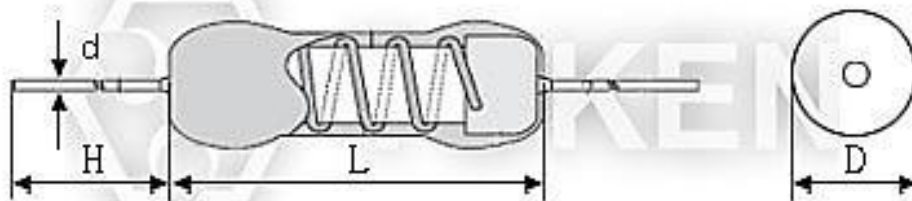

Wire Wound (KNP) Dimensions (Unit: mm)

Electrical Performance

Electrical Performance (KNP)

TEST ITEMS	CONDITION	SPEC
Operating Temperature Range	-55°C ~ 275°C(0W)	
Resistance Temp. Coeff.	Room temperature/100°C up	± 300 PPM / °C
Short Time Overload	10 times of rated wattage for 5 sec.	± 2 %
Rated Load	Rated wattage 30 min.	± 1 %
Voltage Withstanding	500VAC 1 min	± 1 %
Temperature Cycling	-20°C ~ 85°C 5 cycles	± 1 %
Load Life	70°C on ~ off cycle 1000 hrs.	± 5 %
Moisture-Proof Load Life	40°C 95% RH on ~ off cycle 500 hrs.	± 3 %
Incombustibility	16 times of rated wattage for 5 min	not flamed

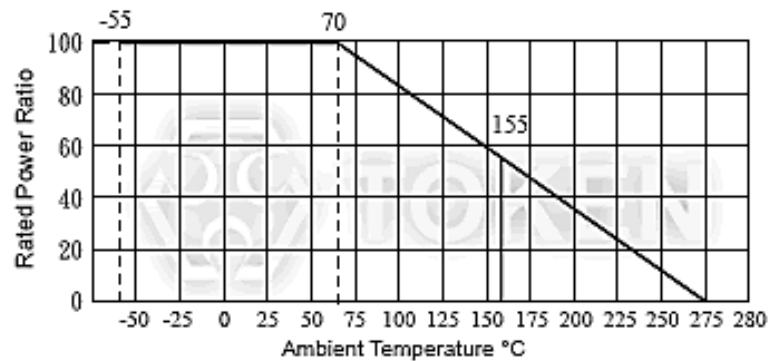

(KNP) Power derating curve

Application Notes

Application Notes of Wire wound Resistors (KNP)

- When being used in AC circuits, some wirewound structures give inductance ingredients or parasitic capacity, so they may cause unusual phenomena such as oscillations etc. Quorum deviations of other components should be carefully taken into account for use.
- Application and Placement: Wire wound resistors use different gauges of wire as resistance elements. Sometimes the gauge is extremely thin (finer than a strand of human hair) and very susceptible to breakage in environments containing salts, ash, dust and corrosives. Avoid utilization in such environments.
- Do not install in dusty areas because the accumulation will cause shorts and poor conductance.

Order Codes

Order Codes (KNP)

KNP-100	1W	10R		J		P	
Part Number	Rated Power (W)	Resistance Value (Ω)		Resistance Tolerance (%)		Package	
KNP		0R1	0.1 Ω	F	$\pm 1\%$	P	Bulk
		1R	1R Ω	G	$\pm 2\%$	TB	Taping Box
		10R	10R Ω	J	$\pm 5\%$		
		100R	100R Ω				
		1K	1K Ω				

► General Information

General Purpose Resistors with Customized Service

Token Electronics is expanding business to include a broad range of General Purpose Resistor products designed for high volume applications. This expanded range of commercial resistor presents a more comprehensive product offering for Customer Experience Management (CEM) and other high volume customers that require quality products at competitive pricing.

Backed by the same customer service, technical support and quality assurance that Token has always provided, these new commercial products enable you the opportunity to source a wider range of resistors from a trusted supplier.

General Use

When an ambient temperature exceeds a rated ambient temperature, resistor shall be applied on the derating curve by derating the load power. General purpose resistor under overloads is not combustion resistant and is likely to emit, flame, gas, smoke, red heat, etc. Flame retardant resistor generally emits smoke and red heat in a certain power and over but do not emit fire or flame.

When resistors are shielded or coated with resin etc., stress from the storage heat and the resins are applied. So, performance and reliability should be checked well before use.

When a voltage higher than rated is applied in a short time (single pulse, repeated pulses, surge, etc.), it does not necessarily ensure safety that an effective wattage is not higher than a rated wattage. Then consult with us with your specified pulse wave shape. Resistors shall be used in a condition causing no dew condensation.

Keep temperature from rising by choosing resistor with a higher rated capacity; do not use a component having the exact load value required. For considerations of safety in extended period applications, the rating should be more than four times higher than the actual wattage involved, but never use resistors at less than 25% of its rated power.

In applications where resistors are subject to intermittent current surges and spikes, be sure in advance that the components selected are capable of withstanding brief durations of increased load.

Do not exceed the recommended rated load. Resistor must use within the rated voltage range to prevent the shortening of service life and/or failure of the wound resistance elements.

Minimum load: Resistor must be utilized at 1/10 or more of the rated voltage to prevent poor conductance due to oxidation build-up. For basic particulars for cautions, refer to EIAJ Technical Report RCR-2121 "Guidance for care note on fixed-resistors".



Non-Inductive Wire wound Resistor (KNPN)

▶ Product Introduction

Non-inductive Wire Wound Resistor Improves Inductance for High Frequency Applications.

Features :

- Low cost
- Excellent pulse load capability
- Non-inductive Ayrton Perry winding
- A wide resistance range 0.1Ω to 50Ω
- A wide range of power ratings 0.5W to 6W
- Operating temperature range -55°C ~ 155°C
- Products with Pb-free Terminations and RoHS compliant

Applications :

- Power tools
- Current sensing
- Consumer applications
- Power supplies, Welders
- High voltage applications
- High-switching applications
- Home entertainment, appliances

Token Electronics has introduced a non-inductive version KNPN resistor of conformal coated, leaded wire wounds. The KNPN non-inductive wire wound resistor offers the expected performance with the added characteristic of vastly improved inductance, making it suitable for high-switching applications.

Wire wound technology has long been known as a leading technology for power resistor needs though it is inherently inductive. Known as Ayrton Perry winding, a non-inductively wound has one winding in one direction and one in the other direction.

By using a non-inductively wound version this greatly reduces the inductance of any given resistor size and value combination; however, it does not completely eliminate the inductance.

This non-inductive winding is available in all standard KNPN sizes from 0.5 watts up to 6 watts with options 1%, 2% and 5% tolerance. The KNPN series is RoHS compliant and also can be supplied with radial, goalpost or lancet preformed leads.

To address your need for technical and economic success in a timely manner, our custom solutions are available. Contact us with your specific needs. Or link to Token official website "[General Purpose Resistors](http://www.token.com.tw)" for more information.



General Specifications

General Specifications (KNPN)

Type	Rated Watts	Dimensions (Unit: mm)				Resistance Range (Ω)	Tolerance
		$D \pm 0.5$	$L \pm 1$	$H \pm 3$	$d \pm 0.05$		
KNPN	KNPN-50	1/2W	4	9.0	26	0.50~0.55	$\pm 1\%$ $\pm 2\%$ $\pm 5\%$
	KNPN-100	1W	4	9.0	26	0.50~0.55	
	KNPN-100B	1W	4.5	11.5	26	0.75~0.80	
	KNPN-200	2W	4.5	11.5	26	0.75~0.80	
	KNPN-200B	2W	5.5	15.5	35	0.75~0.80	
	KNPN-300	3W	5.5	15.5	35	0.75~0.80	
	KNPN-400	4W	6.5	17.5	35	0.75~0.80	
	KNPN-500	5W	6.5	17.5	35	0.75~0.80	
	KNPN-500B	5W	8.5	24.5	38	0.75~0.80	
	KNPN-600	6W	8.5	24.5	38	0.75~0.80	

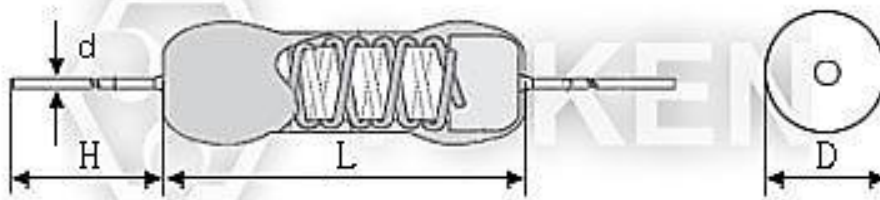

Non-inductive Resistor (KNPN) Dimensions

Electrical Performance

Electrical Performance (KNPN)

TEST ITEMS	CONDITION	SPEC
Operating Temperature Range	-55°C ~ 275°C (0W)	
Resistance Temp. Coeff.	Room temperature/100°C up	± 300 PPM /°C
Short Time Overload	10 times of rated wattage for 5 sec.	± 2 %
Rated Load	Rated wattage 30 min.	± 1 %
Voltage Withstanding	500VAC 1 min	± 1 %
Temperature Cycling	-20°C ~ 85°C 5 cycles	± 1 %

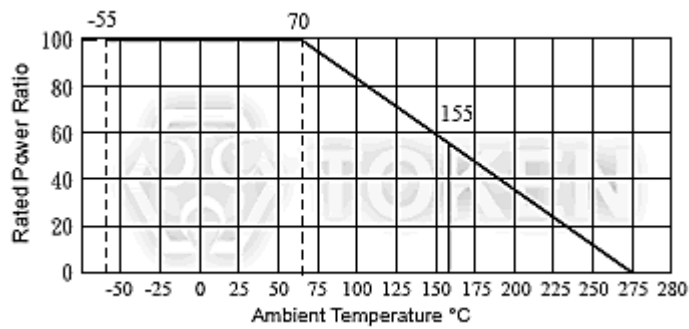

(KNPN) Power derating curve

▶ Application Notes

Application Notes of Non-inductive Wire Wounds (KNPN)

- When being used in AC circuits, some wirewound structures give inductance ingredients or parasitic capacity, so they may cause unusual phenomena such as oscillations etc.
Quorum deviations of other components should be carefully taken into account for use.
- Application and Placement: Wire wound resistors use different gauges of wire as resistance elements. Sometimes the gauge is extremely thin (finer than a strand of human hair) and very susceptible to breakage in environments containing salts, ash, dust and corrosives. Avoid utilization in such environments.
- Do not install in dusty areas because the accumulation will cause shorts and poor conductance.

▶ Order Codes

Order Codes (KNPN)

KNPN-100	1W	10R		J		P	
Part Number	Rated Power (W)	Resistance Value (Ω)		Resistance Tolerance (%)		Package	
KNPN		0R1	0.1 Ω	F	$\pm 1\%$	P	Bulk
		1R	1 Ω	G	$\pm 2\%$	TB	Taping Box
		1R2	1.2 Ω	J	$\pm 5\%$		
		10R	10 Ω				
		12R	12 Ω				



► General Information

General Purpose Resistors with Customized Service

Token Electronics is expanding business to include a broad range of General Purpose Resistor products designed for high volume applications. This expanded range of commercial resistor presents a more comprehensive product offering for Customer Experience Management (CEM) and other high volume customers that require quality products at competitive pricing.

Backed by the same customer service, technical support and quality assurance that Token has always provided, these new commercial products enable you the opportunity to source a wider range of resistors from a trusted supplier.

General Use

When an ambient temperature exceeds a rated ambient temperature, resistor shall be applied on the derating curve by derating the load power. General purpose resistor under overloads is not combustion resistant and is likely to emit, flame, gas, smoke, red heat, etc. Flame retardant resistor generally emits smoke and red heat in a certain power and over but do not emit fire or flame.

When resistors are shielded or coated with resin etc., stress from the storage heat and the resins are applied. So, performance and reliability should be checked well before use.

When a voltage higher than rated is applied in a short time (single pulse, repeated pulses, surge, etc.), it does not necessarily ensure safety that an effective wattage is not higher than a rated wattage. Then consult with us with your specified pulse wave shape. Resistors shall be used in a condition causing no dew condensation.

Keep temperature from rising by choosing resistor with a higher rated capacity; do not use a component having the exact load value required. For considerations of safety in extended period applications, the rating should be more than four times higher than the actual wattage involved, but never use resistors at less than 25% of its rated power.

In applications where resistors are subject to intermittent current surges and spikes, be sure in advance that the components selected are capable of withstanding brief durations of increased load.

Do not exceed the recommended rated load. Resistor must use within the rated voltage range to prevent the shortening of service life and/or failure of the wound resistance elements.

Minimum load: Resistor must be utilized at 1/10 or more of the rated voltage to prevent poor conductance due to oxidation build-up. For basic particulars for cautions, refer to EIAJ Technical Report RCR-2121 "Guidance for care note on fixed-resistors".



Power Wire wound Resistor (KNP-R)

▶ Product Introduction

Power Wire Wound Resistors Boast Consistent Precision Power Operation.

Features :

- Excellent load life stability
- High Precision and reliability
- Axial ceramic-silicone coated
- Meets the Standards of MIL-R-26E
- RoHS compliant with 100% lead free

Applications :

- Radar, Ground Vehicles
- Communications systems
- Bias supply, Current shunts, Voltage dropping
- Motor speed controls, Voltage divider networks
- Medical instrumentation and Medical implantables

Token's highest quality conformal axial terminal ceramic-silicone coated KNP-R power resistors for applications requiring high stability and precision. The KNP-R wire-wound has a low temperature coefficient and maintain a high degree of stability under demanding conditions.

The power precision KNP-R series meeting MIL-R-26E (U and V characteristics) and surface temperature (hot spot) 375°C max. Resistors with a wide range of 0.01Ω ~ 82kΩ, covering applications from precision to power. Products with lead-free terminations meet EU RoHS and China RoHS requirements.



Operating temperature range is -55°C ~ +375°C and derated power at high ambient temperatures as according to the chart below. Token is equipped to design and produce custom components to meet many design and reliability demands. In addition to standard military-grade resistor products, we also have many resistive products designed to meet various source-controlled drawings.

Contact us with your specific needs. Or link to Token official website "[General Purpose Resistors](http://www.token.com.tw)" for more information.

Characteristics U:

275°C Maximum hot spot temperature. 1% Maximum ΔR in 1000 hours load life.

Characteristics V:

375°C Maximum hot spot temperature. 3% Maximum ΔR in 1000 hours load life.



Technical Specifications

Technical Specifications (KNP-R)

Type	MIL - R-26E	Power Rating (W)		Max. Working Voltage (V)		Resistance Range (Ω)		Dimensions (Unit: mm)		
		U (275°C)	V (375°C)	U (275°C)	V (375°C)	0.1%, 0.25%, 0.5%	1%, 2%, 3%, 5%	L \pm 0.81	D \pm 0.81	d \pm 0.1
KNP-R1/4	-	0.40	-	20	-	10~950	1~3.4K	6.35	1.98	0.51
KNP-R1/2	RW70	0.75	-	29	-	10~1.3K	1~4.9K	7.92	1.98	0.51
KNP-R1A	-	1.00	-	53	-	1~2.7K	0.1~10.4K	10.31	2.36	0.64
KNP-R1	RW69	1.10	-	62	-	1~4.0K	0.1~15K	13.49	2.36	0.64
KNP-R2A	-	2.50	3.25	138	157	1~8.6K	0.01~32.3K	12.70	5.33	0.81
KNP-R2	RW79	3.00	3.75	135	148	1~5K	0.01~2K	13.49	4.06	0.81
KNP-R3A	-	3.00	3.75	135	148	1~6.5K	0.01~34.5K	14.27	5.33	0.81
KNP-R3	-	3.25	4.75	185	220	1~11.4K	0.01~42.1K	20.62	5.33	1.02
KNP-R4	RW67	4.00	5.50	210	250	1~12.7K	0.01~47.1K	15.88	7.62	1.02
KNP-R5	RW74	5.00	6.50	330	376	0.5~24.5K	0.01~51K	22.22	7.62	1.02
KNP-R7	RW68	7.00	9.00	504	576	0.5~41.4K	0.01~75K	30.94	9.52	1.02
KNP-R10	RW78	10.00	13.00	799	911	0.5~71.3K	0.01~82K	45.21	9.52	1.02

Power Derating Curve

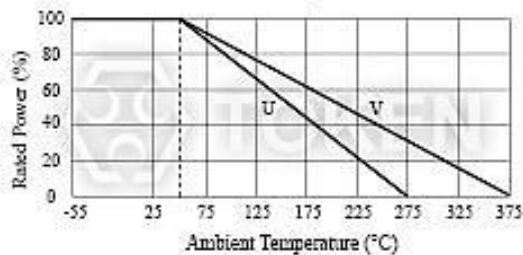

KNP-R Power Derating Curve

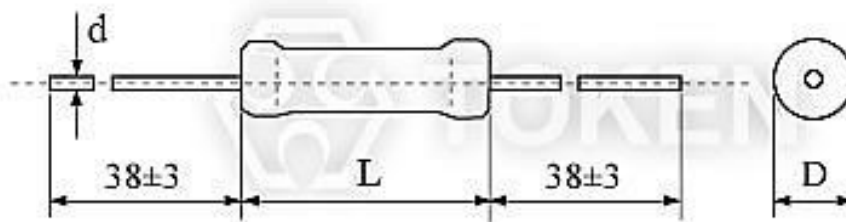

Power Precision Wire Wound Resistor (KNP-R) Dimensions

- Temperature Coefficient: 1 Ω and below \pm 150 ppm/ $^{\circ}$ C, 1 Ω to 9.9 Ω \pm 100 ppm/ $^{\circ}$ C, 10 Ω and above \pm 100 ppm/ $^{\circ}$ C, (50 ppm/ $^{\circ}$ C on request)

Electrical Performance

Electrical Performance (KNP-P)

Test Items	Test Method	Specifications
Short Time Overload	2.5 times of rated voltage 5 sec.	$\Delta R \pm (2\% + 0.05\Omega)$
Rated Load	Rated wattage 30 minutes.	$\Delta R \pm (1\% + 0.05\Omega)$
Voltage Withstanding	500VAC 1 minute.	$\Delta R \pm (1\% + 0.05\Omega)$
Insulation Resistance	500V	20M Ω
Temp. Cycle	-20°C ~ 85°C 5 cycles	$\Delta R \pm (1\% + 0.05\Omega)$
Soldering After Resistance	235°C for 3 sec	$\Delta R \pm (0.5\% + 0.05\Omega)$
Incombustibility	16 times of rated wattage for 5 min.	Not flamed
Load Life	+25°C, 1.5Hrs on ~ 0.5Hrs off cycle, 1000 Hrs.	U: $\Delta R \pm (1\% + 0.05\Omega)$ V: $\Delta R \pm (3\% + 0.05\Omega)$

Application Notes

Application Notes of Wire wounds (KNP-R)

- When being used in AC circuits, some wirewound structures give inductance ingredients or parasitic capacity, so they may cause unusual phenomena such as oscillations etc. Quorum deviations of other components should be carefully taken into account for use.
- Application and Placement: Wirewound resistors use different gauges of wire as resistance elements. Sometimes the gauge is extremely thin (finer than a strand of human hair) and very susceptible to breakage in environments containing salts, ash, dust and corrosives. Avoid utilization in such environments.
- Do not install in dusty areas because the accumulation will cause shorts and poor conductance.

Order Codes

Order Codes (KNP-R)

KNP-R3A	U	100R	B	P
Part Number	Characteristic (°C)	Resistance Value (Ω)	Resistance Tolerance (%)	Package
KNP-R	U 275°C V 375°C	0R1 1.0Ω 1R 1Ω 100R 100Ω 1K 1000Ω	B ±0.1% C ±0.25% D ±0.5% F ±1% G ±2% H ±3% J ±5%	P Bulk TB Taping Box

► General Information

General Purpose Resistors with Customized Service

Token Electronics is expanding business to include a broad range of General Purpose Resistor products designed for high volume applications. This expanded range of commercial resistor presents a more comprehensive product offering for Customer Experience Management (CEM) and other high volume customers that require quality products at competitive pricing.

Backed by the same customer service, technical support and quality assurance that Token has always provided, these new commercial products enable you the opportunity to source a wider range of resistors from a trusted supplier.

General Use

When an ambient temperature exceeds a rated ambient temperature, resistor shall be applied on the derating curve by derating the load power. General purpose resistor under overloads is not combustion resistant and is likely to emit, flame, gas, smoke, red heat, etc. Flame retardant resistor generally emits smoke and red heat in a certain power and over but do not emit fire or flame.

When resistors are shielded or coated with resin etc., stress from the storage heat and the resins are applied. So, performance and reliability should be checked well before use.

When a voltage higher than rated is applied in a short time (single pulse, repeated pulses, surge, etc.), it does not necessarily ensure safety that an effective wattage is not higher than a rated wattage. Then consult with us with your specified pulse wave shape. Resistors shall be used in a condition causing no dew condensation.

Keep temperature from rising by choosing resistor with a higher rated capacity; do not use a component having the exact load value required. For considerations of safety in extended period applications, the rating should be more than four times higher than the actual wattage involved, but never use resistors at less than 25% of its rated power.

In applications where resistors are subject to intermittent current surges and spikes, be sure in advance that the components selected are capable of withstanding brief durations of increased load.

Do not exceed the recommended rated load. Resistor must use within the rated voltage range to prevent the shortening of service life and/or failure of the wound resistance elements.

Minimum load: Resistor must be utilized at 1/10 or more of the rated voltage to prevent poor conductance due to oxidation build-up. For basic particulars for cautions, refer to EIAJ Technical Report RCR-2121 "Guidance for care note on fixed-resistors".



High Precision Wire wound Resistor (BWW)

► Product Introduction

(BWW) Precision Power Resistors

Operate in Harsh Environments.

Features :

- Axial Moulded
- Excellent load life stability
- Insulation, Moisture Proof
- High Precision and reliability
- Meets the Standards of MIL-R-93
- RoHS compliant with 100% lead free

Applications :

- Electrical loads, Filament dropping
- DC/DC converters, AC/DC inverters
- High-voltage bleeders, Dynamic braking
- Capacitor charging/discharging regulation
- Motor speed controls, Voltage divider networks
- Bias supply, Current shunts, Voltage dropping, Crow-bar circuits

The new BWW series moulded axial leaded wire wound resistors from Token use high-purity alumina ceramic cores with wire winding which spot are welded by precision CNC machine tools to ensure total operational consistency throughout.

Also, using advanced encapsulation die/mould technologies, these precision power resistors are encapsulated with epoxy molding compound.

The BWW models possess a wide resistance value from 0.1Ω to 39KΩ and meet the stringent requirements of MIL-R-93. Ayrton Perry non-inductive windings are available on request. The BWW precision version has low Ohmic values for current sensing applications.

All versions are miniaturized for better power to dimension ratios and are available in 0.5W to 10W rated power at 25°C. Tolerance is available in ±0.1%, ±0.25%, ±0.5%, ±1% and ±2% with TCR ±25PPM/°C, ±50PPM/°C and ±150PPM/°C which makes them ideally suited for use in precision applications.

The BWW series is RoHS compliant with 100% Sn (lead free) coated terminals. To address your need for technical and economic success in a timely manner, our custom solutions are the best option. Contact us with your specific needs. Or link to Token official website "[General Purpose Resistors](http://www.token.com.tw)" for more information.



Technical Specifications

Technical Specifications (BWW)

Type	Rated Watts at 25°C (W)	Resistance Range (Ω)		Tolerance (%)	TCR (PPM/°C)	Dimensions (Unit: mm)			
		Min	Max			A±0.25	ΦB±0.25	Φd	F
BWW-0.5	0.5	0.1	100	±0.1 ±0.25 ±0.5 ±1 ±2 ±5	±25 ±50 ±150	7.0	3.0	0.8	27.0
BWW-1	1.0	0.1	1K			11.0	3.0	0.8	31.0
BWW-3	3.0	0.1	10K			15.0	5.2	0.8	34.0
BWW-4	4.0	0.1	15K			18.0	6.5	0.8	38.0
BWW-5	5.0	1	24K			24.0	8.4	1.0	44.0
BWW-10	10.0	1	39K			46.5	10.0	1.0	66.0

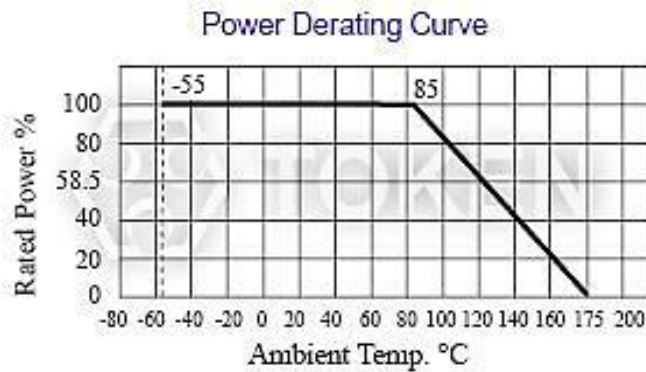

(BWW) Power Derating Curve

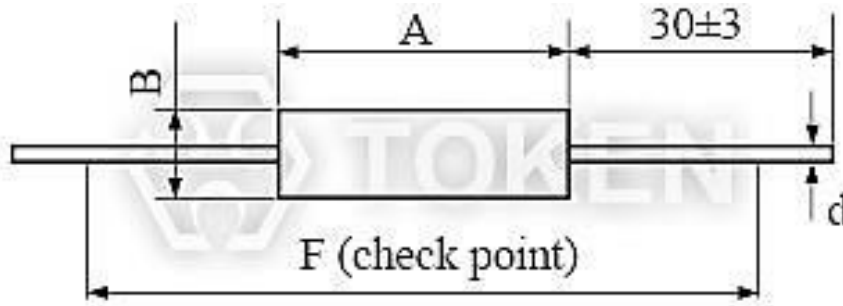

Precision Wire wound (BWW) Dimensions

Electrical Performance

Electrical Performance (BWW)

Test Items	Test Conditions	Specifications
Operating Temp. Range		-55°C ~ 175°C
Insulation Resistance	500V	>1GΩ
Dielectric Withstanding Voltage	500V AC 1 Min.	$\Delta R \leq \pm 0.1\%R$
Load Life	70°C on~off cycle 1000 Hrs.	$\Delta R \leq \pm 1\%R$
Moisture-Proof Load Life	40°C 95% RH on~off cycle 21 Hrs.	$\Delta R \leq \pm 0.2\%R$
Resistance to soldering heat	350°C, 3.5s	$\Delta R \leq \pm 0.1\%R$
Solderability	235±5°C, 5s(solder bath method)	IEC68-2-20(1968)

Application Notes

Application Notes of Wire wounds (BWW)

- When being used in AC circuits, some wirewound structures give inductance ingredients or parasitic capacity, so they may cause unusual phenomena such as oscillations etc. Quorum deviations of other components should be carefully taken into account for use.
- Application and Placement: Wire wound resistors use different gauges of wire as resistance elements. Sometimes the gauge is extremely thin (finer than a strand of human hair) and very susceptible to breakage in environments containing salts, ash, dust and corrosives. Avoid utilization in such environments.
- Do not install in dusty areas because the accumulation will cause shorts and poor conductance.

Order Codes

Order Codes (BWW)

BWW	-	1W	100R	F	D	P
Part Number		Rated Power (W)	Resistance Value (Ω)	Resistance Tolerance (%)	TCR (PPM/°C)	Package
BWW			0R1 0.1Ω 100R 100Ω 1K 1000Ω	B ±0.1% C ±0.25% D ±0.5% F ±1% G ±2%	C ±25PPM/°C D ±50PPM/°C K ±150PPM/°C	P Bulk

► General Information

General Purpose Resistors with Customized Service

Token Electronics is expanding business to include a broad range of General Purpose Resistor products designed for high volume applications. This expanded range of commercial resistor presents a more comprehensive product offering for Customer Experience Management (CEM) and other high volume customers that require quality products at competitive pricing.

Backed by the same customer service, technical support and quality assurance that Token has always provided, these new commercial products enable you the opportunity to source a wider range of resistors from a trusted supplier.

General Use

When an ambient temperature exceeds a rated ambient temperature, resistor shall be applied on the derating curve by derating the load power. General purpose resistor under overloads is not combustion resistant and is likely to emit, flame, gas, smoke, red heat, etc. Flame retardant resistor generally emits smoke and red heat in a certain power and over but do not emit fire or flame.

When resistors are shielded or coated with resin etc., stress from the storage heat and the resins are applied. So, performance and reliability should be checked well before use.

When a voltage higher than rated is applied in a short time (single pulse, repeated pulses, surge, etc.), it does not necessarily ensure safety that an effective wattage is not higher than a rated wattage. Then consult with us with your specified pulse wave shape. Resistors shall be used in a condition causing no dew condensation.

Keep temperature from rising by choosing resistor with a higher rated capacity; do not use a component having the exact load value required. For considerations of safety in extended period applications, the rating should be more than four times higher than the actual wattage involved, but never use resistors at less than 25% of its rated power.

In applications where resistors are subject to intermittent current surges and spikes, be sure in advance that the components selected are capable of withstanding brief durations of increased load.

Do not exceed the recommended rated load. Resistor must use within the rated voltage range to prevent the shortening of service life and/or failure of the wound resistance elements.

Minimum load: Resistor must be utilized at 1/10 or more of the rated voltage to prevent poor conductance due to oxidation build-up. For basic particulars for cautions, refer to EIAJ Technical Report RCR-2121 "Guidance for care note on fixed-resistors".



Zero Ohm & Jumper Wire Resistors (ZO, JW)

► Product Introduction

||| A Quick Solution to PCB Board Connections.

Features :

- Maximum resistance 0.05Ω
- RoHS compliant with 100% lead free
- Lead Material: Tin-plated copper lead
- Ideal straight - through between point on PCB Boards
- Packing: Tape/Reeled or Bulk

Applications :

- Interrupt processing
- Input and output distribution
- Ideal connection for circuit boards
- Dummy components on a PCB test board

Jumper Wire (JW series a zero-ohm link) and zero-ohm resistor (ZO series) are a link used to connect traces on a printed circuit board that is packaged in the same format as a resistor.

The resistance of JW and ZO series is only approximately zero; only a maximum 0.05Ω is specified. Thus, a fractional tolerance (as a percentage of the zero-ohm ideal value) would be infinite and is not specified.

Axial through-hole zero-ohm resistors are especially suited for automatic machine insertion and generally marked with a single black band.

Token's JW and ZO Series offer a quick solution to the following problems:

1. Circuit tuning by changing point connections.
2. An "after the fact design" that requires new point connections.
3. Inability to connect two points on a PCB board due to other circuit paths which must be crossed over.

Allowing customers to standardize on the PCB layout and use jumper wire and zero ohm resistor for required model variations, Token has developed a wider version for the interconnection device between points on a PCB board as jumper wires or crossovers. Contact us with your specific needs. For more information, please link to Token official website "[General Purpose Resistors](http://www.token.com.tw)".



► ZO General Specification

General Specification (Unit: mm) Zero Ohm Resistor (ZO)

Type	Rating	Dimension (mm)			
		L Max.	D Max.	H ± 3	d+0.02-0.04
ZO - 1/8	0.125W	4.2	2.0	28	0.5
ZO - 1/4	0.25W	6.8	2.5	28	0.5

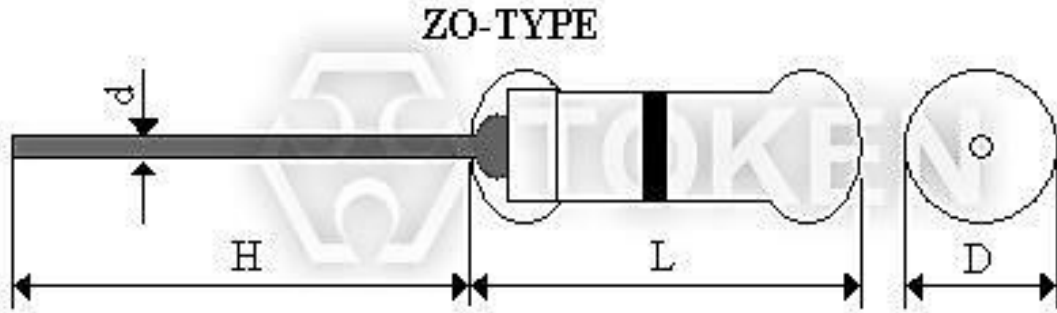

Zero Ohm Resistors (ZO) Dimensions

► JW General Specification

General Specification (Unit: mm) Jumper Wire (JW)

Type	L±1	d+0.02 -0.04	H	P
JW-A	61.5	0.5	3 - 10	5 - 30
JW-B	61.5	0.6	3 - 10	5 - 30

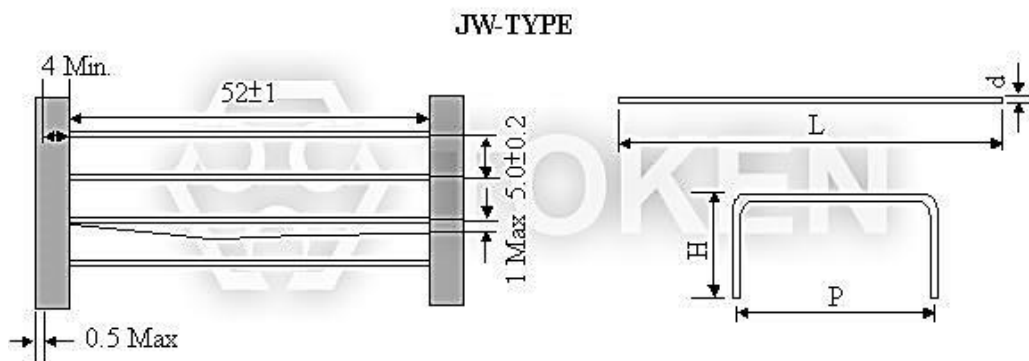

Jumper Wire (JW) Dimensions

► Electrical Performance

Electrical Performance (ZO, JW)

Requirements	Characteristics
Maximum Resistance	0.05Ω
Lead Material	tin-plead copper
Body Material	Electrical grade, high performance molding compound
Dielectric Withstanding Voltage	Atomspheric-500V RMS, Reduced-325V RMS
Insulation Flammability	Resistor Insulation is self-extinguishing within 10 seconds after externally applied flame is removed.
Current Rating	25 AMPS at 25°C, dreading to 0 AMPS at 150°C

► Order Codes

Order Codes (ZO, JW)

ZO-1/4	0.25W	TB	
Part Number	Rated Power (W)	Package	
ZO-1/4	0.25W	P	Bulk
ZO-1/8	0.125W	TB	Taping Box
JW-A			
JW-B			

► General Information

General Purpose Resistors with Customized Service

Token Electronics is expanding business to include a broad range of General Purpose Resistor products designed for high volume applications. This expanded range of commercial resistor presents a more comprehensive product offering for Customer Experience Management (CEM) and other high volume customers that require quality products at competitive pricing.

Backed by the same customer service, technical support and quality assurance that Token has always provided, these new commercial products enable you the opportunity to source a wider range of resistors from a trusted supplier.

General Use

When an ambient temperature exceeds a rated ambient temperature, resistor shall be applied on the derating curve by derating the load power. General purpose resistor under overloads is not combustion resistant and is likely to emit, flame, gas, smoke, red heat, etc. Flame retardant resistor generally emits smoke and red heat in a certain power and over but do not emit fire or flame.

When resistors are shielded or coated with resin etc., stress from the storage heat and the resins are applied. So, performance and reliability should be checked well before use.

When a voltage higher than rated is applied in a short time (single pulse, repeated pulses, surge, etc.), it does not necessarily ensure safety that an effective wattage is not higher than a rated wattage. Then consult with us with your specified pulse wave shape. Resistors shall be used in a condition causing no dew condensation.

Keep temperature from rising by choosing resistor with a higher rated capacity; do not use a component having the exact load value required. For considerations of safety in extended period applications, the rating should be more than four times higher than the actual wattage involved, but never use resistors at less than 25% of its rated power.

In applications where resistors are subject to intermittent current surges and spikes, be sure in advance that the components selected are capable of withstanding brief durations of increased load.

Do not exceed the recommended rated load. Resistor must use within the rated voltage range to prevent the shortening of service life and/or failure of the wound resistance elements.

Minimum load: Resistor must be utilized at 1/10 or more of the rated voltage to prevent poor conductance due to oxidation build-up. For basic particulars for cautions, refer to EIAJ Technical Report RCR-2121 "Guidance for care note on fixed-resistors".



Heating Resistors (HR)

► Product Introduction

Token Ceramic Thermal Far Infrared Heating Resistors (HR) with Customized Design.

Features :

- Performance and stability, long service life.
- Materials for corrosion-resistant ceramic glaze, a wide range of hand-hygiene requirements are high or corrosive gas environment.
- For the efficient, new home appliances, high efficiency, excellent features, good seismic performance, simple and precise temperature control, energy saving.
- Components of a wide range of baked products, a good drying effect.
- A very good impact resistance voltage capability, high durability.
- Are widely used in industrial production, household appliances, medical equipment.

Token thermal far-infrared radiation ceramic glaze membrane components electric membrane is the introduction of new materials and new technologies produced a new generation of high-temperature membrane electric products, which compared to conventional electric heating elements have an unparalleled advantage.

Contact us with your specific needs. For more information, please link to Token official website "[General Purpose Resistors](http://www.token.com.tw)".



► Dimensions

(HR) Dimensions (Unit: mm)

Type	$L \pm 3.0$	$\Phi D \pm 2.0$	$\Phi d \pm 2.0$	$B \pm 2.0$
HR	250	12	9.5	13
	250	16	12	13
	250	21	17	13
	250	25	19	13

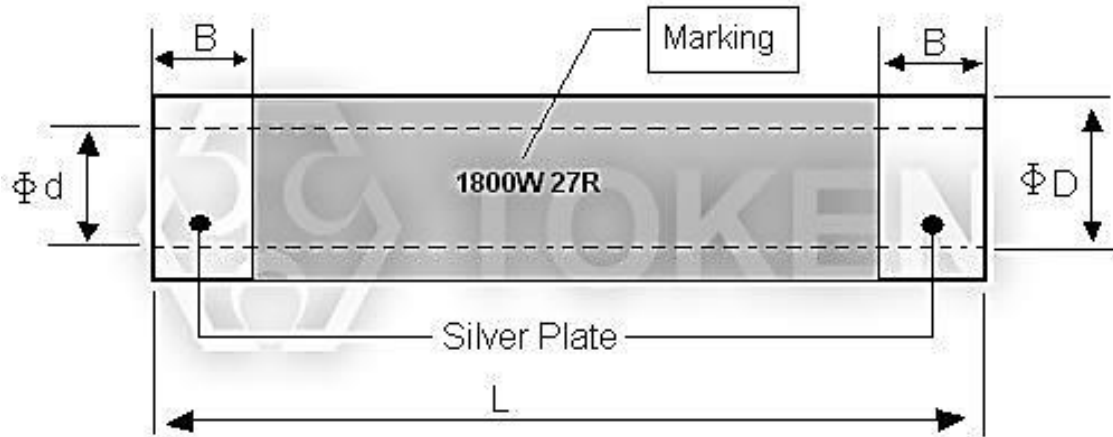

Heating Resistors - HR Series Dimensions

- Remark: For $\Phi D=12$ Type, the length upon customized request up to 340mm.
For $\Phi D=16$, $\Phi D=21$ and $\Phi D=25$ Type, the length upon customized request up to 600mm.
B: upon request.

► Specifications

(HR) Specifications

Type	Resistance Range	Resistance Tolerance	Rated Power	Working Voltage	Operating Temperature
HR	1Ω ~ 10KΩ	K (±10%) M (±20%)	1W ~ 3000W	220V	650°C Max.

► Electrical Specifications

(HR) Electrical Specifications

Parameters	Heat Resistors	GB4654-84GB7287-87
Service life	>10000h	>2000h
Directional radiation	>91%	>83%
Electric radiation conversion rate	>61.5%	50%
Power attenuation	<3%	/
Thermal response time	<4min	20min
Spectral range	2.5-50μm	/
Peak wavelength of radiation power	4.5μm	/
Radiation mode	Directly heater, no thermal heating wire.	/

▶ Advantage Heat Resistors

Advantage Ceramic glaze electric components on film (HR) Heat Resistors

High temperature electric heating element is the use of membrane technology, new materials; new technology developed from a new generation of highly efficient energy-saving electric products, Heat Resistor HR is not a conventional electric heating electric wire, with traditional electric heating of different ways.

Electric high temperature membrane through special technology, a unique formula will be a variety of high temperature chemical element in the growth of high-strength composite ceramic substrate surface conductive heat generated films, and its surface covered in a layer of the far-infrared very thin insulating layer to Strength then its far-infrared radiation, increase the insulation properties and acid and alkali, moisture resistant.

High temperature electric heating elements of the resistance film has a good positive temperature coefficient (PTC) characteristics of long-term use of non-power recession, thus ensuring more than 10,000 hours life of components.

Film high temperature electric heating elements used for high-intensity special ceramic matrix, the high temperature membrane for electric heat source, the maximum temperature up to 800°C (General Electric film can only work at 300°C below) so stable performance.

High temperature electric heating elements major film performance indicators have reached or exceeded the international advanced level infrared radiation components.

As high temperature electric heating element is a membrane surface heating elements, with small size, light weight, small thermal inertia, heat a very short response time, the heating elements maximum spectral wavelengths and water, paint, textile and chemical fiber materials absorb infrared wavelength consistent, so heating range.

Far-infrared emission rate of 0.90 for the test, high temperature electric heating elements than the membrane electric wire, electric power saving of more than 30~40 percent.

▶ Order Codes

Heating Resistor (HR) Order Codes

HR	1800	B	27Ω	K	220V	450C	S	Black
Product Type	Power Rating	Type	Resistance Value	Resistance Tolerance	Working Voltage	Operating Temperature	Silver plate terminal	Color
		A Quartz		K ±10%				
		B Ceramic						

► General Information

General Purpose Resistors with Customized Service

Token Electronics is expanding business to include a broad range of General Purpose Resistor products designed for high volume applications. This expanded range of commercial resistor presents a more comprehensive product offering for Customer Experience Management (CEM) and other high volume customers that require quality products at competitive pricing.

Backed by the same customer service, technical support and quality assurance that Token has always provided, these new commercial products enable you the opportunity to source a wider range of resistors from a trusted supplier.

General Use

When an ambient temperature exceeds a rated ambient temperature, resistor shall be applied on the derating curve by derating the load power. General purpose resistor under overloads is not combustion resistant and is likely to emit, flame, gas, smoke, red heat, etc. Flame retardant resistor generally emits smoke and red heat in a certain power and over but do not emit fire or flame.

When resistors are shielded or coated with resin etc., stress from the storage heat and the resins are applied. So, performance and reliability should be checked well before use.

When a voltage higher than rated is applied in a short time (single pulse, repeated pulses, surge, etc.), it does not necessarily ensure safety that an effective wattage is not higher than a rated wattage. Then consult with us with your specified pulse wave shape. Resistors shall be used in a condition causing no dew condensation.

Keep temperature from rising by choosing resistor with a higher rated capacity; do not use a component having the exact load value required. For considerations of safety in extended period applications, the rating should be more than four times higher than the actual wattage involved, but never use resistors at less than 25% of its rated power.

In applications where resistors are subject to intermittent current surges and spikes, be sure in advance that the components selected are capable of withstanding brief durations of increased load.

Do not exceed the recommended rated load. Resistor must use within the rated voltage range to prevent the shortening of service life and/or failure of the wound resistance elements.

Minimum load: Resistor must be utilized at 1/10 or more of the rated voltage to prevent poor conductance due to oxidation build-up. For basic particulars for cautions, refer to EIAJ Technical Report RCR-2121 "Guidance for care note on fixed-resistors".

