

Version:
July 4, 2017



**(Bullet Shape 940)
Infrared Ambient
Light Sensors**

Token Electronics Industry Co., Ltd.

Taiwan: No.137, Sec. 1, Zhongxing Rd., Wugu District,
New Taipei City, Taiwan, R.O.C. 24872
Tel: +886 2981 0109 Fax: +886 2988 7487

China: 12F, Zhong Xing Industry Bld., Chuang Ye Road,
Nan Shan District, Shen Zhen City,
Guang Dong, China 518054
Tel: +86 755 26055363; Fax: +86 755 26055365

Web: www.token.com.tw

Email: rfq@token.com.tw



▶ Product Introduction

With RoHs compliant, Token IR phototransistors are available in a wide range of packages.

Features :

- Good batch consistency, small static current.
- Fast response speed, stable performance, beautiful appearance.
- The effective control distance is greater than 1.5 meters.
- Low current loss in the static.

Applications :

- Replace the traditional CDS photoresistor.
- Cadmium and lead free with RoHS compliant.
- Applicable to control all kinds of light control toys and Infrared testing equipment.

A phototransistor is known as a device in which turns light source energy into electric energy. Phototransistors are very close to photoresistors but produce both current and voltage, while photoresistors simply produce current. The reason is a phototransistor includes a bipolar semiconductor and targets the energy this can be transmitted via it.

Phototransistors are light-sensitive transistors. A common type of phototransistor resembles a bipolar transistor with its base lead removed and replaced with a light-sensitive area. This is why a phototransistor has only 2 terminals instead of the usual 3. However, when the light-sensitive region is exposed to light, a small base current is generated that controls a much larger collector-to-emitter current.

Token (Bullet Shape 940) with environmentally friendly photosensitive sensor, control sensitivity under low illumination, stable current signal output under strong light source. Multiple light at the same time can be used to ensure consistent photosensitive effect, not false trigger. Meet the latest environmental requirements of toys. Applicable to all kinds of light control lighting products (such as night lights, lawn lamps, solar lights, etc.), automatically adjust the background light (such as LCD, mobile phones, cameras, computer cameras, security monitoring machines, etc.).

The (Bullet Shape 940) ambient light sensors, commonly used in infrared reception, Ultra-thin multi-point infrared touch screen, and all kinds of high-light or visible light interference strong products, such as various types of infrared light control, infrared on the radio, infrared reflection and other electronic products.

For the convenience of installation in all kinds of products in any position, different sizes are available upon request. So that product consistency is better, more market competitiveness. It is also achievable to provide the bright current / dark current (bright resistance / dark resistance) for the most suitable product. Please contact our sales or link to Token official website "[Light Sensors](http://www.token.com.tw)" for more information.



► Dimensions

Dimensions & Configurations (Unit: mm) (PT-A2-DC-3-BE-940) & (PT-A1-FC-5-BE-940) Bullet Edge

Part NO.	A (mm)	B (mm)	C (mm)	D (mm)	E (mm)	F (mm)	G (mm)	H (mm)	I (mm)
PT-A2-DC-3-BE-940	4.05 ± 0.20	3.00 ± 0.20	1.50 Max.	1.50 ± 0.5	2.54 ± 0.20	5.30 ± 0.20	1.00 ± 0.20	14.0 Min.	0.50 ± 0.20
PT-A1-FC-5-BE-940	5.80 ± 0.20	5.00 ± 0.20	1.50 Max.	1.50 ± 0.5	2.54 ± 0.20	8.70 ± 0.20	1.00 ± 0.20	25.4 Min.	0.50 ± 0.20

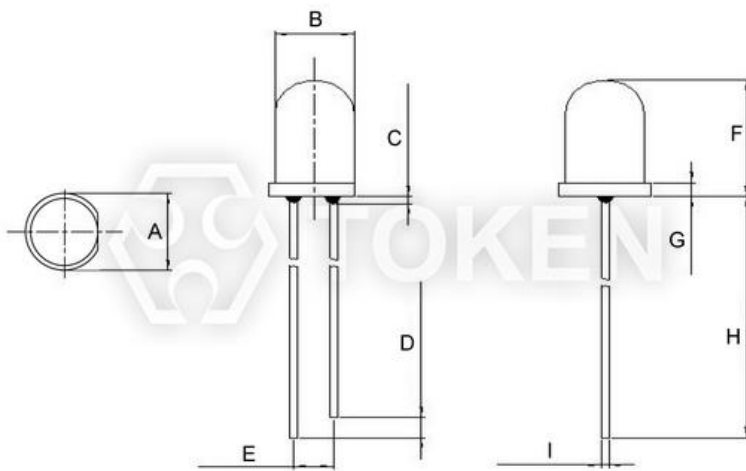

IR Phototransistor Bullet Edge Dimensions



**IR Phototransistor
PT-A1-FC-5-BE-940**



**IR Phototransistor
PT-A2-DC-3-BE-940**

Remark:

- The epoxy resin highest: 1.5mm max.
- Product images, plastic color of appearance, and all other information is for reference only, goods in-kind prevail.
- Short Lead—Collector Long Lead—Emitter.



Dimensions & Configurations (Unit: mm) (PT-A1-DC-5-BN-940) Bullet None

Part NO.	A (mm)	B (mm)	C (mm)	D (mm)	E (mm)	F (mm)	G (mm)	H (mm)
PT-A1-DC-5-BN-940	4.80 ± 0.20	4.80 ± 0.20	1.50 Max.	2.00 ± 0.5	2.54 ± 0.20	8.60 ± 0.20	14.00 Min.	0.50 ± 0.20

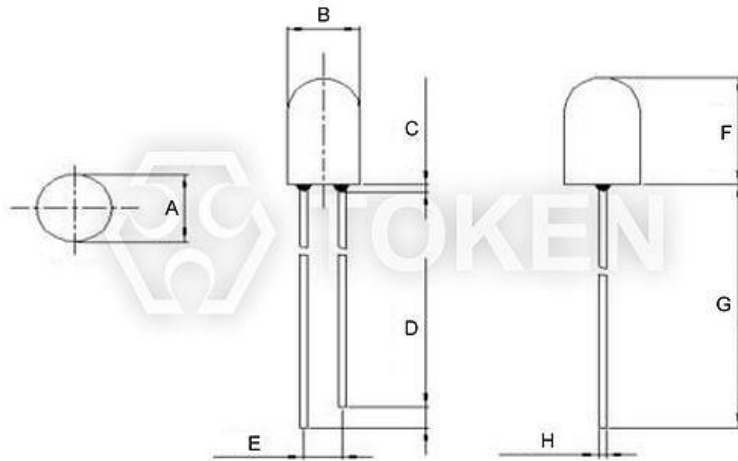

IR Ambient Light Sensor (PT-A1-DC-5-BN-940) Dimensions



IR Ambient Light Sensor
PT-A1-DC-5-BN-940

Remark:

- The epoxy resin highest: 1.5mm max.
- Product images, plastic color of appearance, and all other information is for reference only, goods in-kind prevail.
- Short Lead—Collector Long Lead—Emitter.



▶ **Electro-Optical φ3-940**

Electro-Optical Characteristics (Ta=25 ° C) (PT-A2-DC-3-BE-940) Bullet Edge

Parameter	Symbol	Condition	Min.	Typ.	Max.	Unit
Peak Wavelength	λ_p	\	-	940	-	nm
Spectral Response Bandwidth	λ	\	700	-	1100	nm
Collector-Emitter Breakdown Voltage	B_{veco}	$I_{cc}=100\mu A$ $E_c=0m^W/cm^2$	30	-	-	V
Emitter-Base Breakdown Voltage	B_{veco}	$I_{cc}=100\mu A$ $E_c=0m^W/cm^2$	6	-	-	V
Collector-Emitter Saturation Voltage	V_{ce} (sat)	$I_{cc}=2mA$ $E_c=1m^W/cm^2$	-	-	0.4	V
Collector-Emitter Current	I_{cc}	$V_{cc}=5V$ $E_c=1m^W/cm^2$	0.5	0.8	1.2	mA
Collector Dark Current	I_{cco}	$V_{cc}=5V$ $E_v=0Lux$	-	-	0.1	μA
Rise Time	t_r	$V_{cc}=5V$ $I_{cc}=1mA$	15			ms
Fall Time	t_f	$RL=1000\Omega$	15			

Absolute maximum ratings (Ta=25 ° C) (PT-A2-DC-3-BE-940) Bullet Edge

Parameter	Symbol	Value	Unit
Collector-Emitter Voltage	V_{CEO}	30	V
Emitter-Collector-Voltage	V_{ECO}	6	V
Power Dissipation	P_C	70	m^W
Operating Temperature Range	T_{opr}	-25 ~ +85	°C
Storage Temperature	T_{stg}	-40 ~ +100	°C



▶ **Electro-Optical φ5-940**

Electro-Optical Characteristics (Ta=25 ° C) (PT-A1-FC-5-BE-940) Bullet Edge

Parameter	Symbol	Condition	Min.	Typ.	Max.	Unit
Peak Wavelength	λ_p	\	-	940	-	nm
Spectral Response Bandwidth	λ	\	860	-	1100	nm
Collector-Emitter Breakdown Voltage	$B_{v_{ceo}}$	$I_{cc}=100\mu A$ $E_c=0m^W/cm^2$	30	-	-	V
Emitter-Base Breakdown Voltage	$B_{v_{eco}}$	$I_{cc}=100\mu A$ $E_c=0m^W/cm^2$	3	-	-	V
Collector-Emitter Saturation Voltage	V_{ce} (sat)	$I_{cc}=2mA$ $E_c=1m^W/cm^2$	-	-	0.4	V
Collector-Emitter Current	I_{cc}	$V_{ce}=5V$ $E_c=1m^W/cm^2$	1.0	1.6	2.4	mA
Collector Dark Current	I_{cco}	$V_{ce}=5V$ $E_v=0Lux$	-	-	0.1	μA
Rise Time	t_r	$V_{ce}=5V$ $I_{cc}=1mA$	15			ms
Fall Time	t_f	$RL=1000\Omega$	15			

Electro-Optical Characteristics (Ta=25 ° C) (PT-A1-DC-5-BN-940) Bullet None

Parameter	Symbol	Condition	Min.	Typ.	Max.	Unit
Peak Wavelength	λ_p	\	-	940	-	nm
Spectral Response Bandwidth	λ	\	700	-	1100	nm
Collector-Emitter Breakdown Voltage	$B_{v_{ceo}}$	$I_{cc}=100\mu A$ $E_c=0m^W/cm^2$	30	-	-	V
Emitter-Base Breakdown Voltage	$B_{v_{eco}}$	$I_{cc}=100\mu A$ $E_c=0m^W/cm^2$	3	-	-	V
Collector-Emitter Saturation Voltage	V_{ce} (sat)	$I_{cc}=2mA$ $E_c=1m^W/cm^2$	-	-	0.4	V
Collector-Emitter Current	I_{cc}	$V_{ce}=5V$ $E_c=1m^W/cm^2$	1.0	1.6	2.4	mA
Collector Dark Current	I_{cco}	$V_{ce}=5V$ $E_v=0Lux$	-	-	0.1	μA
Rise Time	t_r	$V_{ce}=5V$ $I_{cc}=1mA$	15			ms
Fall Time	t_f	$RL=1000\Omega$	15			

Absolute maximum ratings (Ta=25 ° C) (φ 5-940)

Parameter	Symbol	Value	Unit
Collector-Emitter Voltage	V_{CEO}	30	V
Emitter-Collector-Voltage	V_{ECO}	3	V
Power Dissipation	P_C	70	m^W
Operating Temperature Range	T_{opr}	-25 ~ +85	°C
Storage Temperature	T_{stg}	-40 ~ +100	°C



► Curve

Relative Spectral Sensitivity vs. Wavelength (PT-A2-DC-3-BE-940)

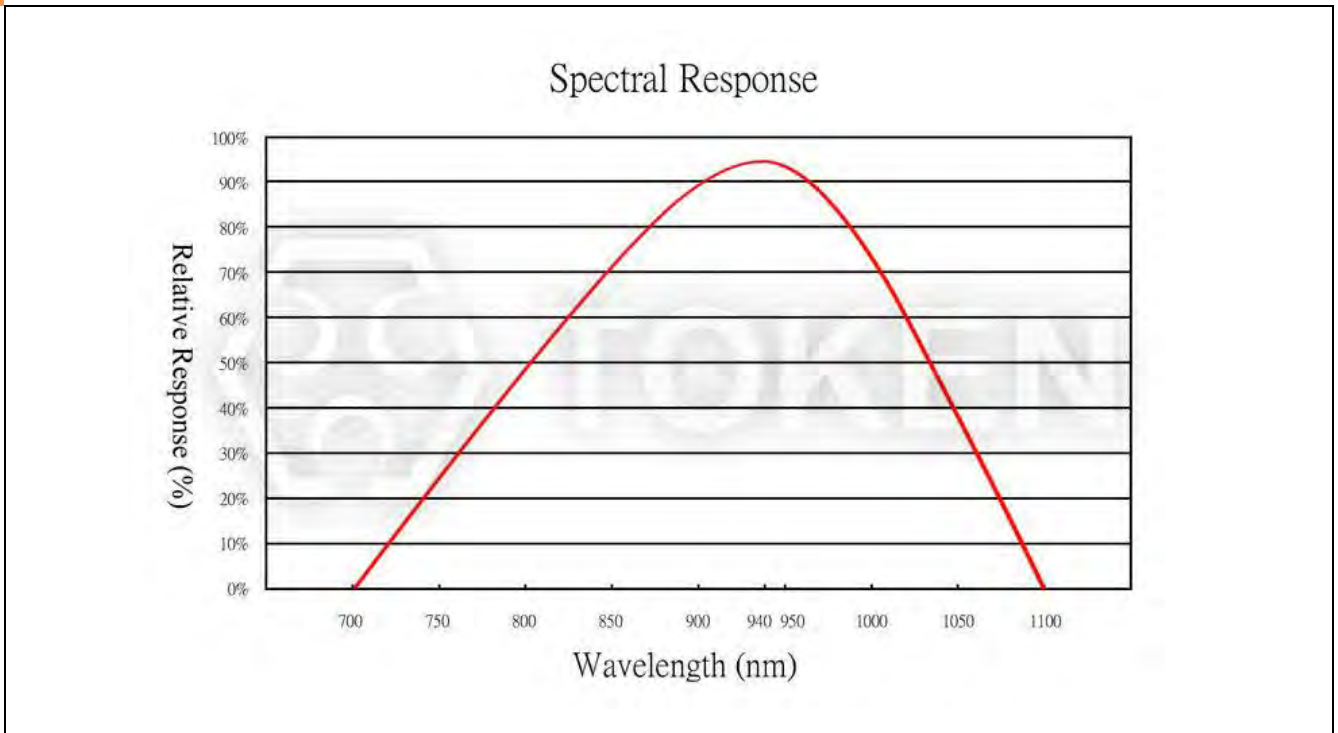

Relative Spectral Sensitivity vs. Wavelength (PT-A1-FC-5-BE-940)

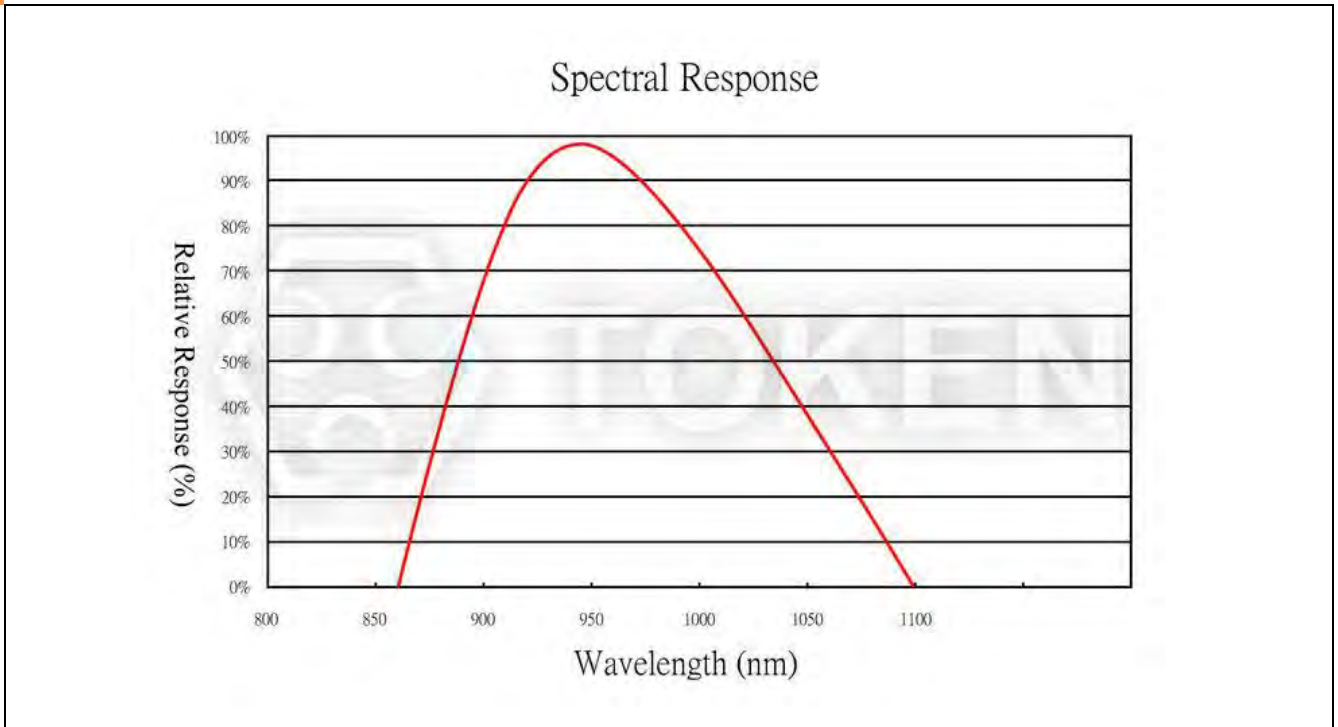

Relative Spectral Sensitivity vs. Wavelength (PT-A1-DC-5-BN-940)

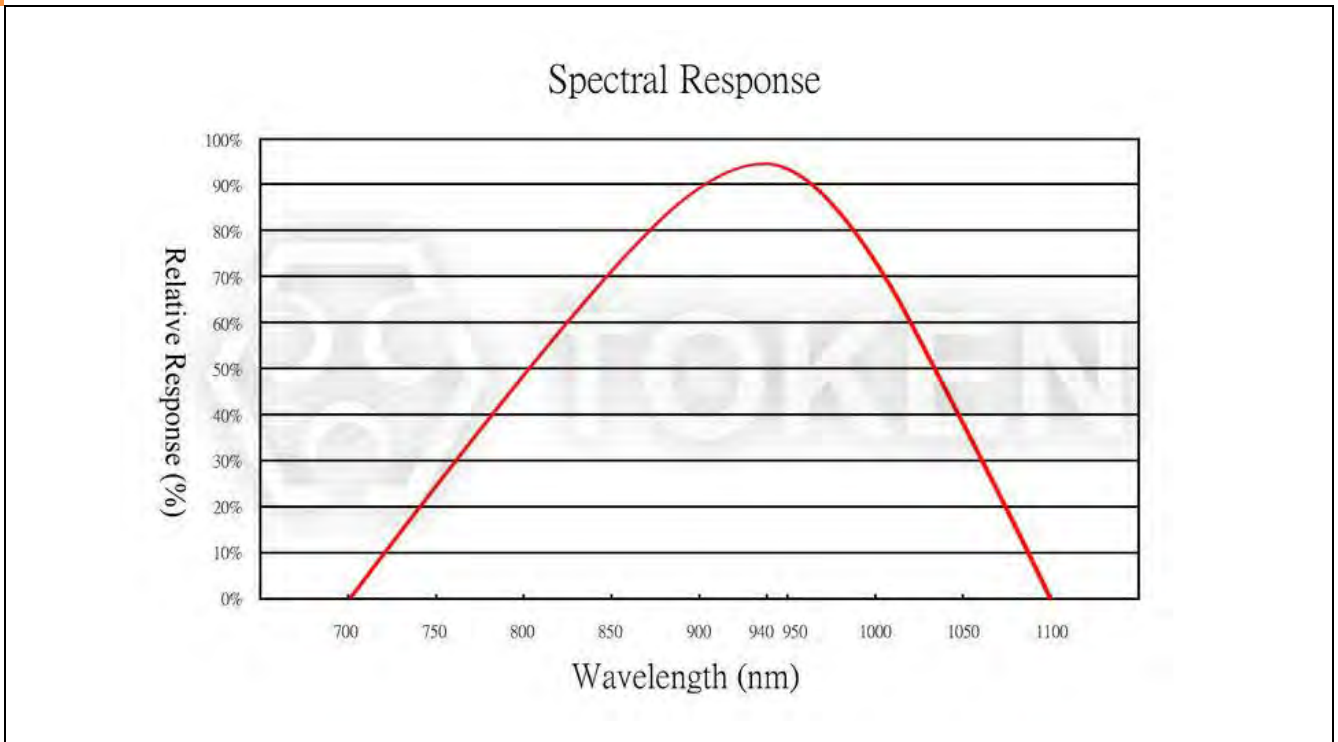

▶ Note

Infrared Phototransistor (Peak Wavelength 940) Precaution Usage

Lead-forming and cuttings:

- Before soldering, perform lead forming at normal temperature.
- While forming or cutting the lead, stay the area at a distance of 5 mm or greater from the root of the lead.
- Avoid mounting which may cause force on the root of the lead.

Mounting:

- While packages are on one circuit board, avoid mismatching in the thermal expansion of each component, generate cracks in the package and break the bonding wire.

Soldering:

- Do not immerse plastic parts in tin tank.
- During soldering, when adding thermal stress in a moisture absorbing state, moisture evaporates, swells and generates stress to the internal package.
- To avoid swellings and cracks in the surface of the package, followsoldering conditions below.
- Wave soldering method: $120^{\circ}\text{C} < 60\text{s}$ 、 $260^{\circ}\text{C} < 5\text{s}$.
- Manual soldering: $260^{\circ}\text{C} < 5\text{s}$ 、 $340^{\circ}\text{C} < 3\text{s}$.

Storage:

The sensor is incorporated in the transparent resin package. Because of its sensitivity to humidity, the package is moisture-proof. When storing the sensor, do as instructed below.

- Quickly use after opening. (within 2 days, below $30^{\circ}\text{C}/60\%$ R.H.).
- Once unpacked, use within three months, or keeping within a moisture-proof method, which include maintaining within a moisture-proof container with silica gels, is suggested for longterm safe-keeping.
- Very bad storage conditions may deteriorate solderability or characteristics, and defect the appearance. Recommended conditions of the storage place, temperature 0°C to 30°C , humidity below 60% R.H. (Avoid freezing and dew condensation).

Cleaning:

- Do not wash with water to avoid corrosion.
- Under any circumstance, the cleaning time should be within 1 minute of normal temperature.
- Alcohol is recommended as a cleaning agent when cleaning products.
- If you use other cleaning agents, you need to confirm whether the cleaning agent will corrode the epoxy body.
- Freon can not be used as a cleaning agent.
- When cleaning products with ultrasonic cleaning, ultrasonic power and time should be less than 300W and 30 seconds, respectively.
- PCB and product can not touch the oscillator. Can not make the product on the PCB resonance.
- This model is static sensitive devices, so static electricity and surges can damage the product.
- To all the equipment, machines, tables, and the ground must be anti-static ground.
- Requires the use of anti-static wrist strap wear.

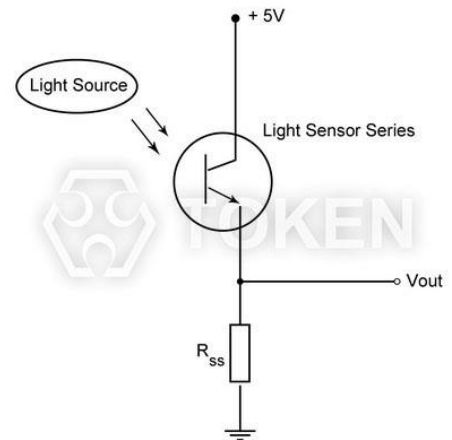

Photo Current Measurement Method
(IR Peak Wavelength 940)

▶ Order Codes

Order Codes (PT-BE/BN-940)

PT	-	A2	-	AC	-	3	-	BE	-	940	
Part Number		Chip Type		Lens Color		Size		Shape		Spectral Bandwidth	
PT		A1		DC	Dark Transparent	3	3mm	BE	Bullet Edge	940	940 nm
		A2		FC	Dark Transparent Anti Visible Light Interference	5	5mm	BN	Bullet None		