

Version:
January 16, 2017

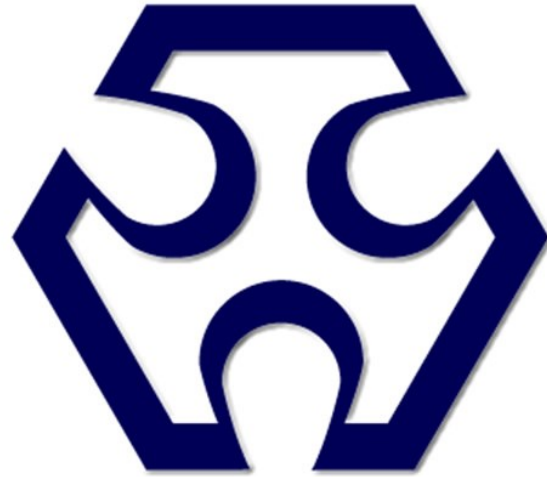

TOKEN

Radial Taping Dimensions of Piezoelectric Devices

Token Electronics Industry Co., Ltd.

Taiwan: No.137, Sec. 1, Zhongxing Rd., Wugu District,
New Taipei City, Taiwan, R.O.C. 24872
Tel: +886 2981 0109 Fax: +886 2988 7487

China: 12F, Zhong Xing Industry Bld., Chuang Ye Road,
Nan Shan District, Shen Zhen City,
Guang Dong, China 518054
Tel: +86 755 26055363; Fax: +86 755 26055365

[Web: www.token.com.tw](http://www.token.com.tw)

[Email: rfq@token.com.tw](mailto:rfq@token.com.tw)



▶ Radial Taping Dimensions

Radial Taping Dimensions of Ceramic Resonators and Ceramic Filters

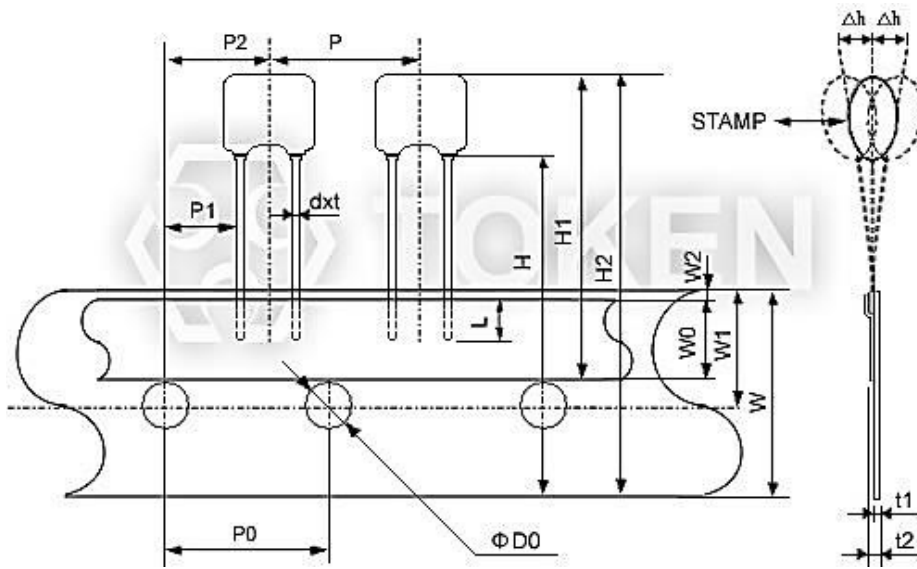

Radial Taping Dimensions of Ceramic Resonators and Ceramic Filters

Mark	Size (Unit: mm)
P	12.7±0.5
P0	12.7±0.2
P1	3.85±0.5
P2	6.35±1.3 *
F	0.5 ^{+0.5} _{-0.3}
dxt	0.5x0.3(±0.1)
W	18.0±0.5
W0	5.5±0.5
W1	9.0±0.5
W2	1.0max
H	18.0 ^{+0.5} _{-1.0}
H1	27.0max **
H2	36.0max **
L	3.0main
ΦD0	4.0±0.2
t1	0.6±0.2
t2	1.5max
Δh	1.0max

● Notes:

- * Include the slant of products.
- ** Varies with part number.

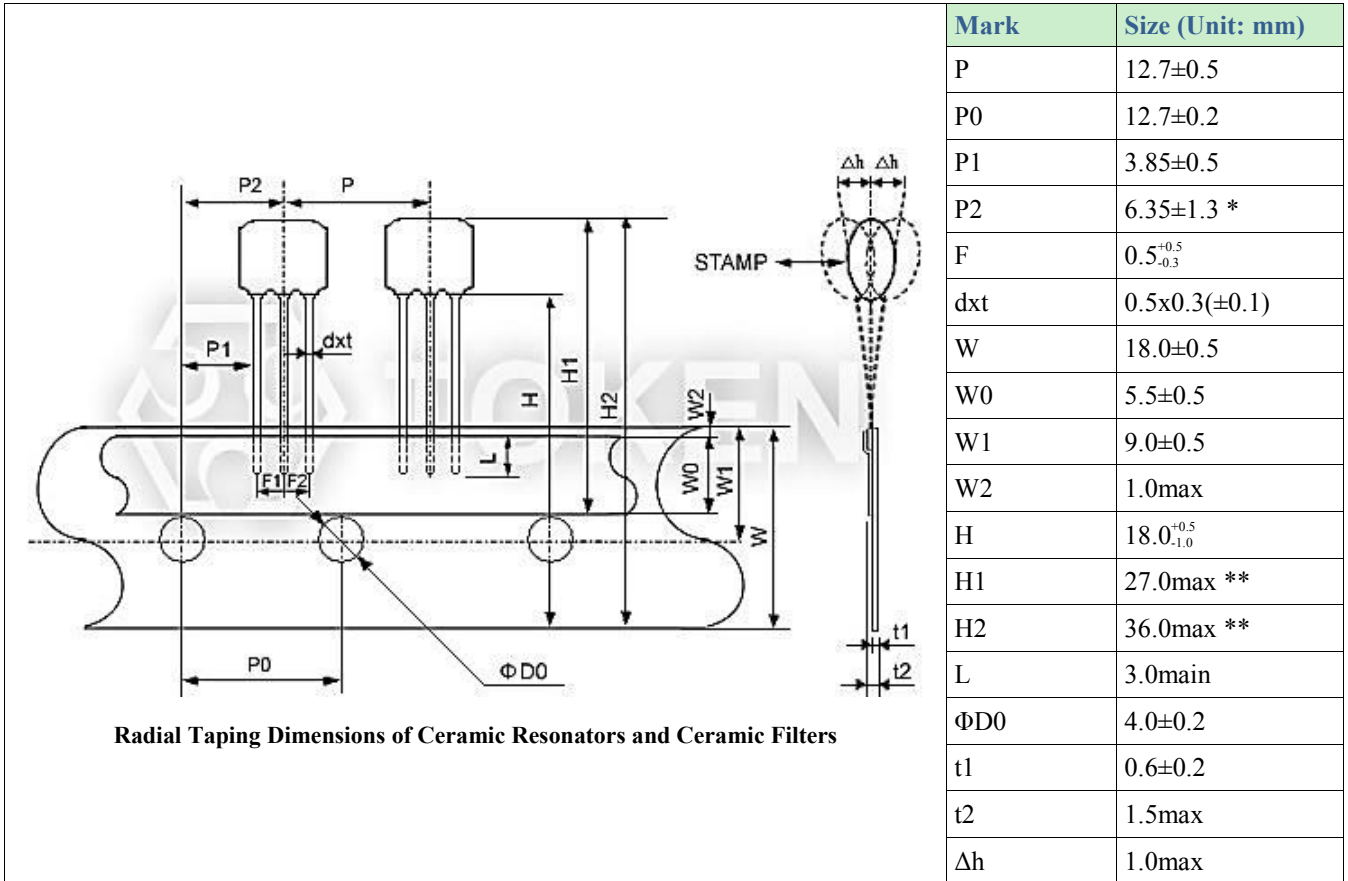

● **Notes:**

- * Include the slant of products.
- ** Varies with part number.

► Packing Method

Packing Method of Ceramic Resonators and Ceramic Filters

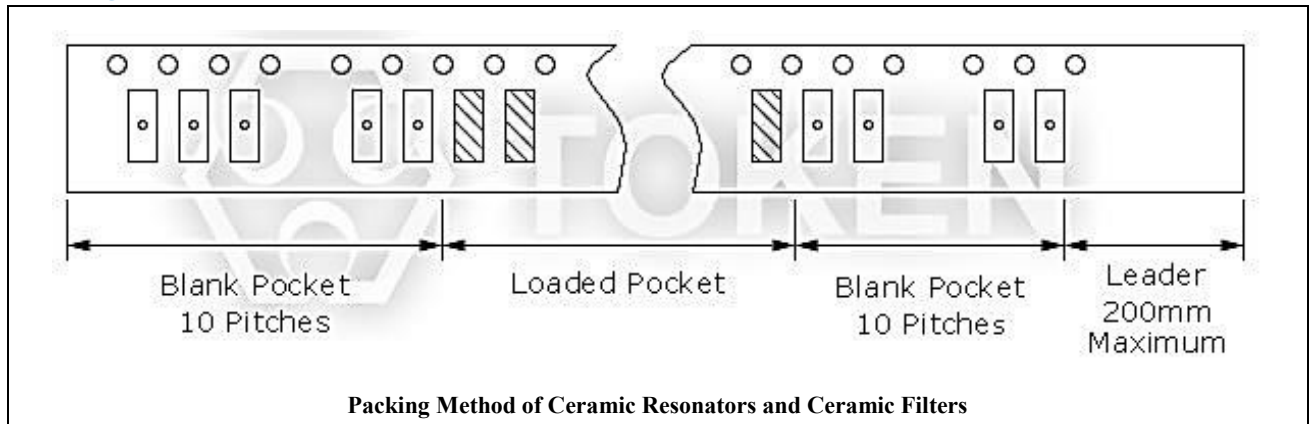

Reel Dimensions (Unit: mm)

ΦA	ΦB	W	T	Pieces per reel	Carrier tape size
179±2	60 typ	8.4 min	14.0max	3000typ	8
179±2	60 typ	12.4 min	19.4max	3000typ	12
179±2	60 typ	12.4 min	19.4max	1000typ	12
179±2	60 typ	16.4 min	22.4max	1000typ	16
330±3	80 min	12.4 min	19.4max	4000typ	12
330±3	80 min	16.4 min	22.4max	4000typ	16

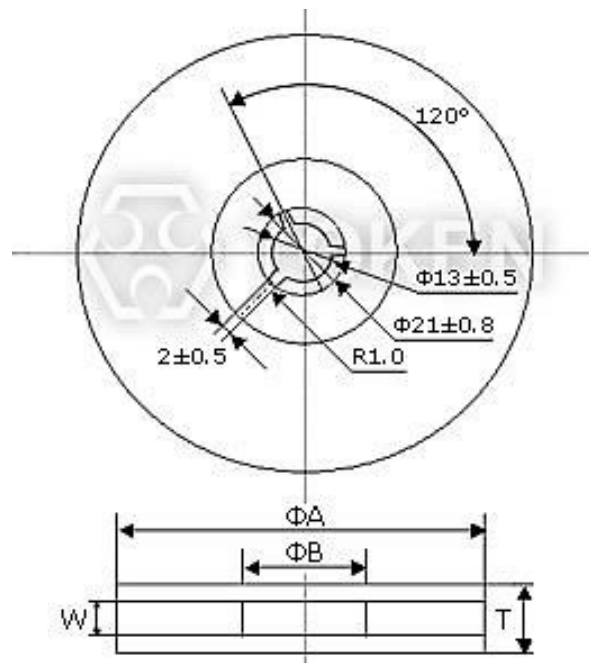

Reel Dimensions of Ceramic Resonators and Ceramic Filters (Unit: mm)

Tape Dimensions (Unit: mm)

Code Tolerance Part Num.	A ±0.2	B ±0.2	C ±0.3	D ±0.1	E ±0.1	F ±0.1	G ±0.1	H ±0.1	ΦJ ±0.1	ΦN ±0.1	M max	R max	K ±0.2	T ±0.1
ZTACC MG ZTCC MG	3.8	7.8	16.0	7.5	1.75	8.0	4.0	2.0	1.5	1.6	10°	0.3	2.1	0.3
ZTACR MG ZTTCR MG	2.2	4.7	12.0	5.5	1.75	4.0	4.0	2.0	1.6	1.6	3°	0.3	1.3	0.3
ZTACS MT/MX ZTCS MT/MX	5.0	4.4	12.0	5.5	1.75	8.0	4.0	2.0	1.5	1.6	10°	0.3	1.8	0.3
ZTACV MT/MX ZTTCV MT/MX	3.4	4.0	12.0	5.5	1.75	8.0	4.0	2.0	1.5	1.6	10°	0.3	1.3	0.3
ZTACW MX ZTTCW MX	2.2	2.8	8.0	3.5	1.75	4.0	4.0	2.0	1.6	1.1	3°	0.3	1.3	0.2

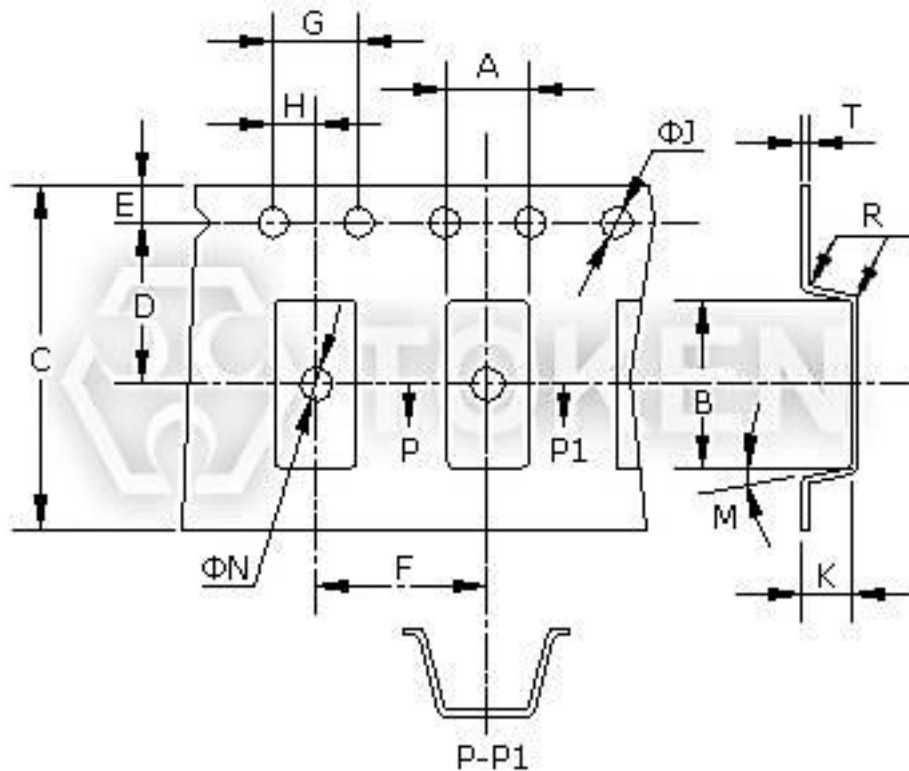

Tape Dimensions of Ceramic Resonators and Ceramic Filters (Unit: mm)

▶ Test Condition and Soldering Condition

Test Condition of Peeling Strength

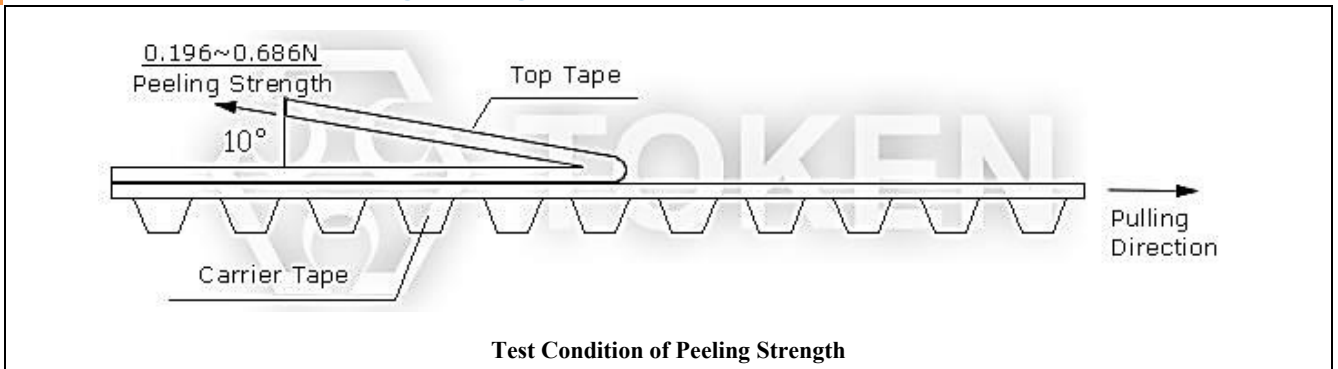

Recommended Reflow Soldering Standard Conditions

