

Version:
September 5, 2017



(DRS)
Smooth Wound
Adjustable Resistor

Token Electronics Industry Co., Ltd.

Taiwan: No.137, Sec. 1, Zhongxing Rd., Wugu District,
New Taipei City, Taiwan, R.O.C. 24872
Tel: +886 2981 0109 **Fax:** +886 2988 7487

China: 12F, Zhong Xing Industry Bld., Chuang Ye Road,
Nan Shan District, Shen Zhen City,
Guang Dong, China 518054
Tel: +86 755 26055363; **Fax:** +86 755 26055365

[Web: www.token.com.tw](http://www.token.com.tw)

[Email: rfq@token.com.tw](mailto:rfq@token.com.tw)



▶ Product Introduction

Choose Token's smooth-wound adjustable power resistor (DRS) for applications requiring settings at different resistance values.

These high energy wire wounds are equipped with an adjustable lug, making them ideal for adjusting circuits, obtaining unique resistance values and setting equipment to meet various line voltages.

DRS resistors feature a hollow core to permit secure fastening with thru bolts with washers or spring-type clips. They also offer the durability of lead free vitreous enamel, or silicone coating and all-welded construction.

The Power (DRS) Adjustable Resistor is RoHS compliant and lead free. For non-standard technical requirements and custom special applications, please contact us. Or link to Token official website "[High Power Resistors](http://www.token.com.tw)" to get more information.



To Calculate Max. Amperes:

- Voltage = (Watts × Ohms)^{1/2}

Power Rating:

- Based on 25°C free air rating. The stated wattage rating applies only when the entire resistance is in the circuit.
- Setting the lug at an intermediate point reduces the wattage rating by approximately the same proportion.
- Example: If the lug is set at half resistance, the wattage is reduced by approximately one-half.
- Wattage is proportional to this adjusted resistance value.
- Adjustability is 10% to 90% of full resistance value.

Features:

- Adjustable lug supplied.
- High wattage applications.
- Flame resistant and rugged lead coating.
- Terminals suitable for soldering or bolt connection.
- Resistance Tolerance: J(±5%), K(±10%).

Options:

- Adjustable, fixed, or tapped styles are available.
- Special terminals available for non-standard applications.
- Single and double quick connect terminals can be specified.
- Standard lug terminals available with or without terminal hardware.
- Non-inductive Ayrton Perry windings can be specified.
- Special temperature coefficients, tolerances



► **DRSA Dimensions**

Dimensions (DRS-A 20W ~ 1300W)

Wattage Rating	Dimensions (Unit: mm)															Max. Pickable Resistance Value (Ω)
	A	B	C	D	E	F	G	H	I	J	K	L	M	N	O	
20W	60	17	8	22	5	78	2	12	4	90	36	1.0	-	6	16	1~150 Ω
30W	80	17	8	22	5	100	2	12	4	112	36	1.0	-	6	16	1~250 Ω
40W	110	17	8	22	5	128	2	12	4	140	36	1.0	-	6	16	1~400 Ω
50W	110	25	16	30	8	150	5	18	6	166	58	1.2	6	-	27	1.5~500 Ω
60W	90	28	18	32	8	130	5	19	6	146	60	1.2	6	-	27	1.5~550 Ω
80W	110	28	18	32	8	150	5	19	6	166	60	1.2	6	-	27	2~650 Ω
100W	140	28	18	32	8	180	5	19	6	196	60	1.2	6	-	27	2~750 Ω
120W	160	28	18	32	8	200	5	19	6	216	60	1.2	6	-	27	3~850 Ω
150W	195	28	18	32	8	235	5	19	6	251	60	1.2	6	-	27	3~1.2K Ω
160W	185	35	24	36	10	225	5	19	8	245	76	1.6	6	-	34	5~1.3K Ω
200W	210	35	24	36	10	250	5	19	8	274	76	1.6	6	-	34	6~1.5K Ω
250W	210	40	25	38	12	250	5	20	8	274	78	1.6	6	-	34	6~2K Ω
300W	260	40	25	38	12	300	5	20	8	320	78	1.6	6	-	34	7~2.5K Ω
400W	330	40	25	38	12	370	5	20	8	395	78	1.6	6	-	34	8~3.5K Ω
500W	330	50	35	50	12	380	6	25	9	400	100	1.6	8	-	40	8~4.5K Ω
600W	400	50	35	50	12	450	6	25	9	470	100	1.6	8	-	40	8~5.5K Ω
700W	460	50	35	50	12	510	6	25	9	530	100	1.6	8	-	40	12~7K Ω
800W	460	60	40	55	15	515	6	30	10	535	110	1.6	10	-	50	12~8K Ω
1000W	540	60	40	55	15	595	6	30	10	615	110	1.6	10	-	50	15~9K Ω
1300W	650	65	42	62	15	702	6	30	10	722	115	1.6	10	-	50	15~11K Ω

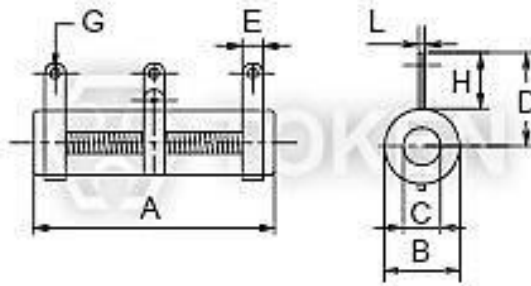

(DRSA) N - No Mount

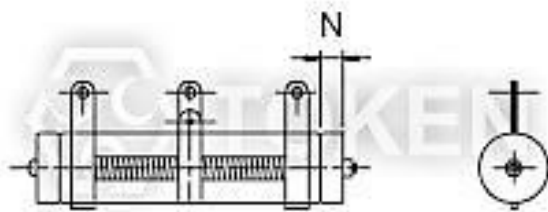

(DRSA) Z - Vertical Mount

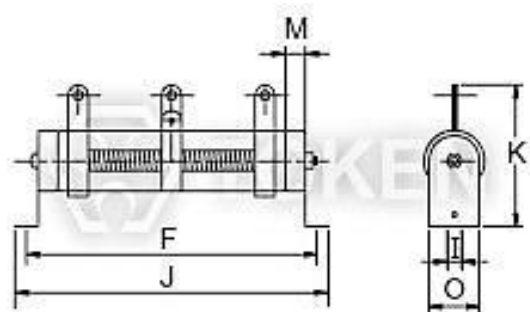

(DRSA) G - Horizontal Mount

► **DRSB Dimensions**

Dimensions (DRSB 15W ~ 20000W)

Wattage Rating	Dimensions (Unit: mm)										Max. Pickable Resistance Value (Ω)
	R	L1	L2	L3	H	N	d	M	q	Q	
15W	15	45	65	85	40	6	3.5	3.5	4.5	15	1~1K Ω
20W	15	50	70	90	40	6	3.5	3.5	4.5	15	1~1K Ω
25W	20	50	80	100	50	6	3.5	5	5	20	2~1K Ω
30W	20	70	100	120	50	6	3.5	5	5	20	2~1K Ω
40W	20	87	115	137	50	6	3.5	5	5	20	2~1K Ω
50W	28	90	115	143	68	9	4.5	5.5	6	27	5~1K Ω
80W	28	90	115	143	68	9	4.5	5.5	6	27	5~2K Ω
100W	28	170	195	223	68	9	4.5	5.5	6	27	10~3K Ω
150W	28	215	240	268	68	9	4.5	5.5	6	27	10~3K Ω
200W	28	267	292	320	68	9	4.5	5.5	6	27	10~5K Ω
250W	28	267	292	320	68	9	4.5	5.5	6	27	10~5K Ω
300W	40	267	300	343	90	10	4.5	6	6	39	20~5K Ω
400W	40	330	365	406	90	10	4.5	6	6	39	20~5K Ω
500W	50	330	365	415	98	10	6	8.5	8	49	20~5K Ω
600W	50	330	365	415	98	10	6	8.5	8	49	20~5K Ω
700W	50	400	435	485	95	10	6	8.5	8	49	20~5K Ω
800W	70	300	320	362	138	15	8	-	8	69	40~500 Ω
1000W	70	300	320	362	138	15	8	-	8	69	40~500 Ω
1500W	70	415	435	477	138	15	8	-	8	69	40~500 Ω
2000W	70	510	530	572	138	15	8	-	8	69	40~500 Ω
2500W	70	600	620	662	138	15	8	-	8	69	40~500 Ω
3000W	70	600	620	662	138	15	8	-	8	69	40~500 Ω
4000W	100	430	450	521	155	15	8	-	8	99	40~500 Ω
5000W	100	500	620	691	155	15	8	-	8	99	40~500 Ω
6000W	100	600	720	791	155	15	8	-	8	99	40~500 Ω
10000W	150	600	625	720	350	30	8	-	10	150	40~500 Ω
12000W	150	660	685	780	350	30	8	-	10	150	40~500 Ω
15000W	150	660	685	780	350	30	8	-	10	150	40~500 Ω
20000W	150	1000	1030	1120	350	30	8	-	10	150	40~500 Ω

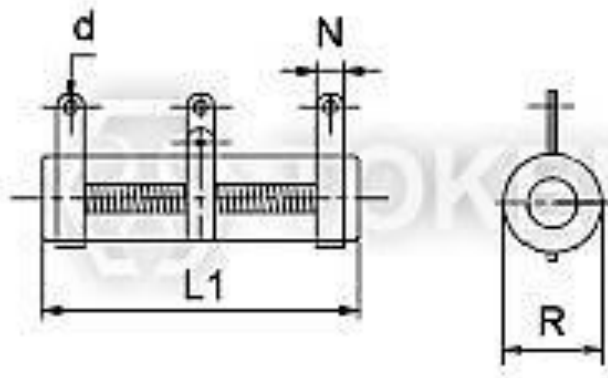

(DRSB) N - No Mount

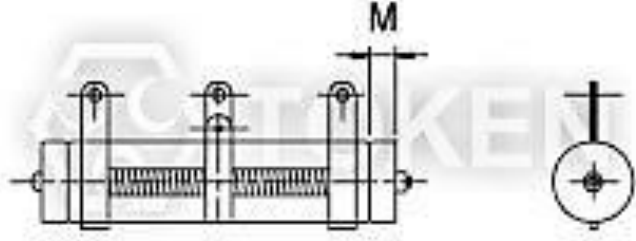
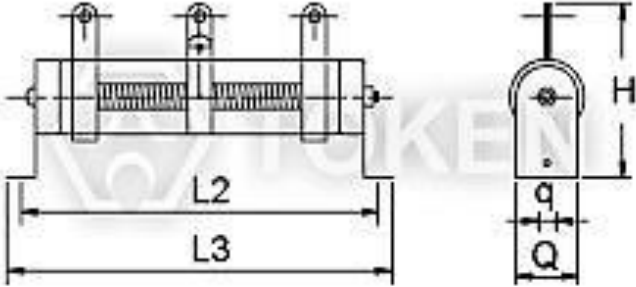
Wattage Rating	Dimensions (Unit: mm)										Max. Pickable Resistance Value (Ω)
	R	L1	L2	L3	H	N	d	M	q	Q	
											
(DRSB) Z - Vertical Mount											
											
(DRSB) G - Horizontal Mount											

Specification

Specification (DRS)

Test Item	Test Methods	Characteristics
Load life	JIS-C-5202 7-10 90 minutes ON - 30 minutes OFF 500 hours	Free of appearance or structural irregularity Surface coating crack $\Delta R/R \leq \pm(1\%+0.05\Omega)$
Load rating	JIS-C-5202 5-4	$\Delta R/R \leq \pm(0.5\%+0.1\Omega)$ Surface temperature up 350°C MAX
Humidity	JIS-C-5202 7-5 40°C 90%RH 240 hours	Free of appearance or structural irregularity Surface coating crack $\Delta R/R \leq \pm(3\%+0.1\Omega)$
Vibration	JIS-C-5202 6-3 1.5m/m 10 ~ 50 ~ 10 Hz/min X-Y-Z 2 hours each	Free of appearance or structural irregularity Surface coating crack $\Delta R/R \leq \pm(1\%+0.05\Omega)$
Thermal shock	JIS-C-5202 7-3 Room temp 30 minutes ON-55°C 15 minutes OFF	Free of structural irregularity $\Delta R/R \leq \pm(2\%+0.1\Omega)$
Terminal strength	JIS-C-5202 6-1 8kg 30 seconds	Free of appearance or structural irregularity
Flame retardation	JIS-C-5202 7-13-3-2 100% - 600% rated wattage load	US UL-94 flame retardation test V-0 grade noncombustible
Resistance tolerance	JIS-C-5202 5-1	Resistance Nominal Tolerance $1 \leq R$ $1 > R$ $\pm 5\% (J) \pm 10\% (K)$
Short-term overload	JIS-C-5202 5-5 1000% rated wattage 5 seconds	Free of appearance or structural irregularity $\Delta R/R \leq \pm(2\%+0.1\Omega)$
Insulation resistance	JIS-C-5202 5-6 500VDC	100M Ω min
Temperature coefficient	JIS-C-5202 5-2	± 200 PPM/°C MAX
Dielectric withstanding voltage	JIS-C-5202 5-7 1000VDC 1 minute Between terminal and anchor stand	Free of appearance or structural irregularity $\Delta R/R \leq \pm(0.1\%+0.05\Omega)$
REMARKS:	1. Resistance and resistance tolerance were tested in-house with micro resistance meter. 2. Coating refers to UL-certified data provided by supplier.	

▶ Application Notes

Application Notes of Adjustable Wire wound (DQS)

Determination of End Resistance Value of FVR, DQS, DSRA, DSRB, BSR, BSQ:

- Resistance Range means you can choose one maximum resistance value (Max. Pickable Resistance / End resistance value) at one of FVR, DQS, DSRA, DSRB, BSR, BSQ VR (Variable Resistor) type.
- After End Resistance Value confirmed, the minimum resistance (start resistance value) will be determined by depending on resistance of wire and wirewound type.

Power Rating of Variable Resistor:

The part Number formation of FVR, DQS, DSRA, DSRB, BSR and BSQ:

Product type - Rated Wattage - Max. Pickable Resistance (Ω) - Resistance Tolerance

Product type means one of FVR, DQS, DSRA, DSRB, BSR, BSQ.

Rated Wattage means power rating at End Resistance Value.

Resistance Value (Ω) means maximum resistance value (End Resistance Value).

Resistance Tolerance means precision range of End Resistance Value.

1. Power Rating of VR (Variable Resistor) is determined by the maximum resistance value (End Resistance Value).
2. Resistance and Power Rating should be decreased while you are adjusting the screw.

Power Rating:

- Based on 25°C free air rating. The stated wattage rating applies only when the entire resistance is in the circuit.
- Setting the lug at an intermediate point reduces the wattage rating by approximately the same proportion.
- Example: If the lug is set at half resistance, the wattage is reduced by approximately one-half.
- Adjustability is 10% to 90% of full resistance value.
- Wattage is proportional to this adjusted resistance value.

If you need current constant type or special specifications, please feel free to contact us.

▶ Order Codes

Order Codes (DRS)

DRSA	600W	250R	J	G
Part Number	Rated Power (W)	Resistance Value	Resistance Tolerance (%)	Assembly Method
DRSA	20W~1300W	0R1 0.1 Ω	J $\pm 5\%$	N No mount.
DRSB	15W~20000W	1R 1 Ω	K $\pm 10\%$	C Clip mount.
		10R 10 Ω		G Horizontal mount.
		100R 100 Ω		Z Vertical mount.
		1K 1K Ω		
		10K 10K Ω		
		100K 100K Ω		

► General Information

Benefits & Features

Providing design engineers with an economical resistor with high quality performance, Token Electronics offers industry grade power wire wound devices.

Token provide terminal blocks, thermal switches, fusing, fans, junction boxes, screened or solid bottom plates, conduit knockouts, and customer specified requirements. For large applications a welded frame construction is utilized to provide a robust design for power resistor mounting in both indoor and outdoor environments.

Products range from large capacity metal clad, nonflammable fixed and adjustable, wave ribbon wire-wound, slide, starter, box type, to nonflammable flat type. Token extends a complete line for both military and commercial applications.

Utilization Notes

1. Smoke emitted from non-flammable resistors on initial use in powered circuits is a normal phenomenon and the component can be safely utilized.
2. All resistors manufactured by Token Electronics Industry Corporation comply with the U.S. UL-94 non- flammability test, Class V-0, a continuous combustion period of zero seconds.
3. Never use organic solvents to clean non-flammable resistors.
4. Non-flammable resistors cannot be utilized in oil.
5. Non-flammable resistors cannot be used in high frequency machinery because of the inductance produced by the windings. A suitable type of resistor must be selected. Contact us for details.
6. In applications where resistors are subject to intermittent current surges and spikes, be sure in advance that the components selected are capable of withstanding brief durations of increased load.
7. Do not exceed the recommended usable load. Resistors must use within the rated voltage range to prevent the shortening of service life and/or failure of the wound resistance elements.
8. Minimum load. Resistors must be utilized at 1/10 or more of the rated voltage to prevent poor conductance due to oxidation build-up.
9. Although the hardness exceeds that of a 3H pencil lead, do not nick the resistor coating with screw drivers or other pointed objects.
10. Avoid touching non-flammable resistors in operation; the surface temperature ranges from approximately 350°C ~ 400°C when utilized at the full rated value. Maintaining a surface temperature of 200°C or less will extend resistor service life.
11. Keep temperature from rising by choosing a resistor with a higher rated capacity; do not use a component having the exact load value required. For considerations of safety in extended period applications, the resistor rating should be more than four times higher than the actual wattage involved, but never use a resistor at less than 25% of its rated power.
12. Application and Placement: Wire-wound resistors use different gauges of wire as resistance elements. Sometimes the gauge is extremely thin (finer than a strand of human hair) and very susceptible to breakage in environments containing salts, ash, dust and corrosives. Avoid utilization in such environments. Do not install in dusty areas because the accumulation will cause shorts and poor conductance.

