

Version:
October 10, 2017



(AH)

Power Precision Heat Sinkable Resistors

Token Electronics Industry Co., Ltd.

Taiwan: No.137, Sec. 1, Zhongxing Rd., Wugu District,
New Taipei City, Taiwan, R.O.C. 24872
Tel: +886 2981 0109 Fax: +886 2988 7487

China: 12F, Zhong Xing Industry Bld., Chuang Ye Road,
Nan Shan District, Shen Zhen City,
Guang Dong, China 518054
Tel: +86 755 26055363; Fax: +86 755 26055365

[Web: www.token.com.tw](http://www.token.com.tw)

[Email: rfq@token.com.tw](mailto:rfq@token.com.tw)



▶ Product Introduction

Outstanding Heat sink Aluminum Housed Wire wound Power Resistors (AH)

Token Electronics aluminum chassis mount units are designed for maximum heat dissipation mounting solidly to metal chassis surface for maximum heat transfer. AH series are outstanding for their high power dissipation with precision tolerances in minimum physical sizes.

Lower hot spot ratings due to exclusive complete encapsulation of element within anodized aluminum body. AH series high-performance welded construction throughout assures long stable load life with threaded heavy stud axial-terminals.



The AH Series is RoHS compliant and lead free. For non-standard technical requirements and custom special applications, please contact us to discuss the details, or link to Token official website "[High Power Resistors](http://www.token.com.tw)" to get more information.

Materials:

- Encapsulant: S: Silicone, C: Cement; End caps: Stainless steel.
- Core: Ceramic steatite or alumina.
- Housing: Aluminum with hard anodic coating.
- Element: Copper-nickel alloy, nickel-chrome alloy or manganese copper.
- AHS Standard Terminals: 5~150 W Tinned terminals, 200~500 W Threaded terminals.
- AHC Standard Terminals: 5~50 W Tinned terminals, 80~300 W Threaded terminals.

General Specification:

- Operating Temperature Range: -55°C to $+275^{\circ}\text{C}$.
- Resistance Tolerance: $\pm 10\%$, $\pm 5\%$, $\pm 2\%$, $\pm 1\%$, $\pm 0.5\%$, $\pm 0.25\%$, $\pm 0.1\%$
- Wattage Range: 11 styles to choose ranging from 5 to 500 watts.

Non-Inductive & Features:

- Ayrton Perry type non-inductive winding is available. When required add "N" to the part number.
- Standard winding & non-inductive winding available. High power rating, strong construction, small size, and ultra precision.
- Aluminum housing allows chassis mounting and provides heat sink capability.

► AHS Dimensions

Heat Sinkable Dimensions (AHS-5, AHS-5N, AHS-10, AHS-10N, AHS-25, AHS-25N, AHS-50, AHS-50N)

Type	A	B	C	D	E	F	G	H	J	Φ L	Φ M	Φ N	P
	± 1.0	± 1.0	± 1.0	± 2.0	± 1.0	± 1.0	± 1.0	± 0.8	± 1.0	± 0.8	± 0.8	± 0.8	Ref.
AHS-5 AHS-5N	11.4	12.5	15.5	31	8.5	16	8	1.5	4.4	2.2	1.2	1.3	8
AHS-10 AHS-10N	14	16	19.5	40.5	11.2	21	10	2	5	2.5	2	2.2	10.5
AHS-25/30 AHS-25/30N	18.3	20	27	48	14.3	27	13	2	7	3.5	2	2.2	10.5
AHS-50 AHS-50N	40	22	50	71	16.3	29	15.5	2	7.3	3.5	2	2.2	10.5

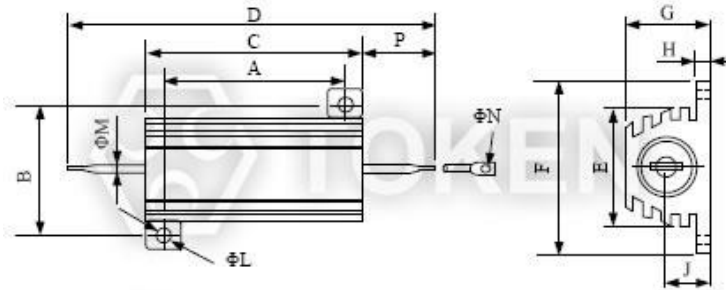

Heat Sinkable Dimensions (AHS)

Heat Sinkable Dimensions (AHS-75, AHS-75N, AHS-100, AHS-100N, AHS-150, AHS-150N)

Type	A	B	C	D	E	F	G	H	J	Φ L	M	Φ N
	± 1.5	± 1.5	± 2.0	± 2.0	± 1.5	± 1.5	± 1.5	± 0.8	± 1.5	± 1.2	± 0.8	± 0.8
AHS-75 AHS-75N	23.5	37	65.5	90	27	48	26	3.5	12	4.5	3	2.7
AHS-100F AHS-100FN	35	37	98	119	27	48	26	3.5	11.5	4.5	2	2.7
AHS-150 AHS-150N	52	37	130	151	27	48	26	3.5	11.5	4.5	3	2.7

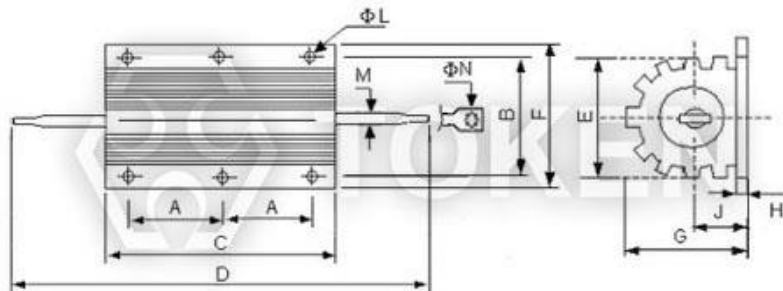

Heat Sinkable Dimensions Dimensions (AHS)

Heat Sinkable Dimensions (AHS-200, AHS-200N, AHS-250F, AHS-250FN, AHS-300, AHS-300N, AHS-500, AHS-500N)

Type	A	B	C	D	E	F	G	H	J	Φ M	Φ N
	± 2.5	± 2.5	± 3.5	± 2.5	± 2.5	± 3.5	± 2.5	± 1.5	± 2.0	± 1.5	± 1.5
AHS-200 AHS-200N	35	58	92	151	46.5	72	45	5	20	M5	5.5
AHS-250F AHS-250FN	45	60	112	165	46.5	73	45	5	21	M6	5.5
AHS-300 AHS-300N	51	58	130	170	46.5	73	45	5	21	M6	5.5
AHS-500 AHS-500N	87	58	204	244	46.5	73	45	5	21	M6	5.5

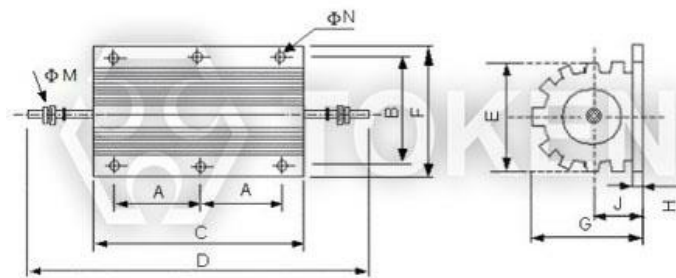

Heat Sinkable Dimensions (AHS)

Heat Sinkable Dimensions (AHS-250, AHS-250N)

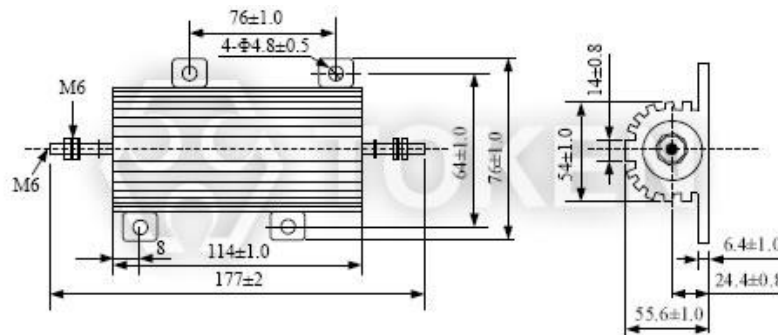

Heat Sinkable Dimensions (AHS)

AHC Dimensions

Heat Sinkable Dimensions (AHC-5, AHC-5N, AHC-10, AHC-10N, AHC-25, AHC-25N, AHC-50, AHC-50N)

Type	A	B	C	D	E	F	G	H	J	Φ L	Φ M	Φ N	P
	± 1.0	± 1.0	± 1.0	± 2.0	± 1.0	± 1.0	± 1.0	± 0.8	± 1.0	± 0.8	± 0.8	± 0.8	Ref.
AHC-5 AHC-5N	10	12.5	15	25	8.5	16.5	8	1.5	4	2	1.2	1.3	5
AHC-10 AHC-10N	14	15.5	19	32	10.5	20	10	2	5	2	2	2.2	6
AHC-25 AHC-25N	18	19	27	47	15	27	15.5	2	7	3.2	2	2.2	10
AHC-50 AHC-50N	39	21	50	70	15	29	15.5	2	7	3.2	2	2.2	10

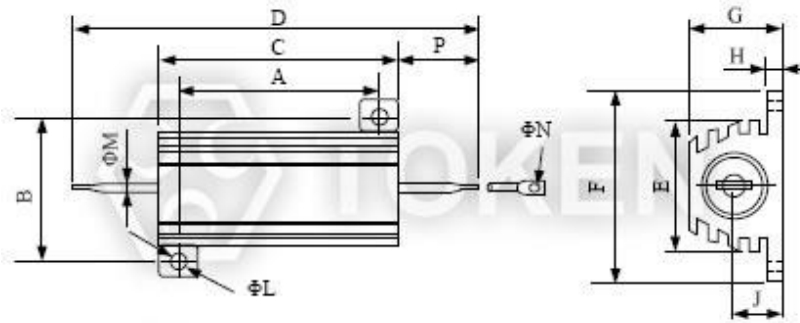

Heat Sinkable Dimensions (AHC)

Heat Sinkable Dimensions (AHC-80, AHC-80N, AHC-100S, AHC-100SN)

Type	A	B	C	D	E	F	G	H	J	Φ L	Φ M
	± 1.5	± 1.5	± 2.0	± 2.0	± 1.5	± 1.5	± 1.5	± 0.8	± 1.5	± 1.2	± 1.5
AHC-80 AHC-80N	35	37	66	102	28	47	25	3.5	12	4.5	M5
AHC-100S AHC-100SN	35	37	66	102	28	47	25	3.5	12	4.5	M5

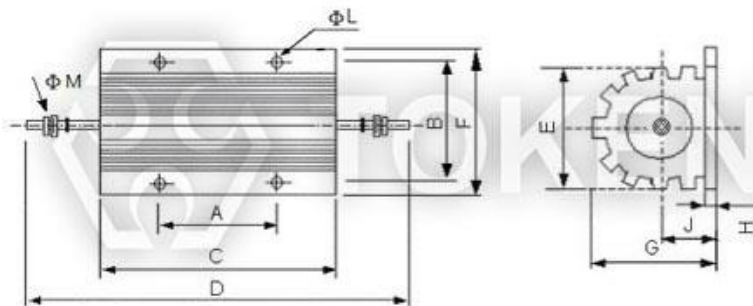

Heat Sinkable Dimensions (AHC)

Heat Sinkable Dimensions (AHC-100, AHC-100N)

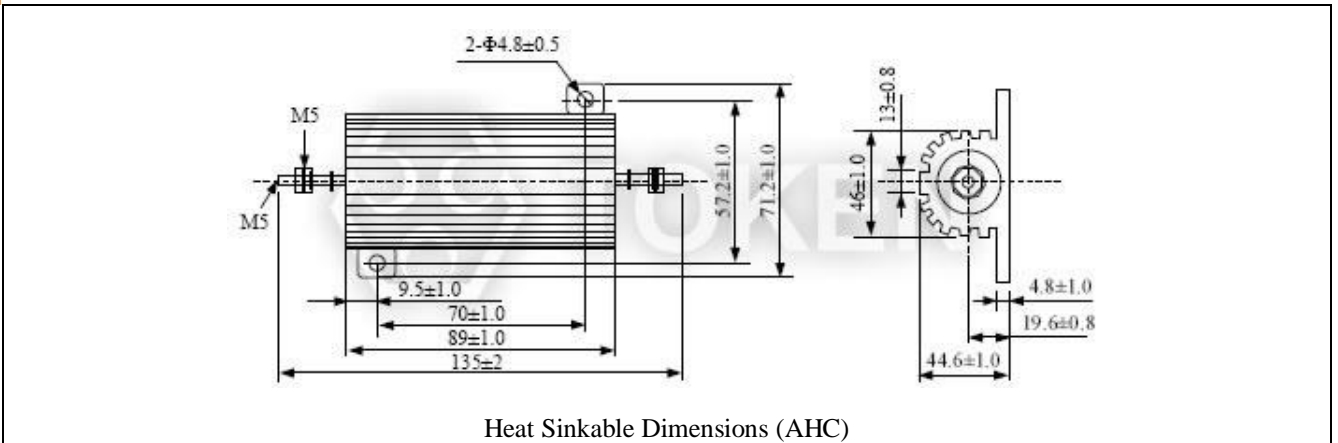

Heat Sinkable Dimensions (AHC-250, AHC-250N, AHC-300, AHC-300N)

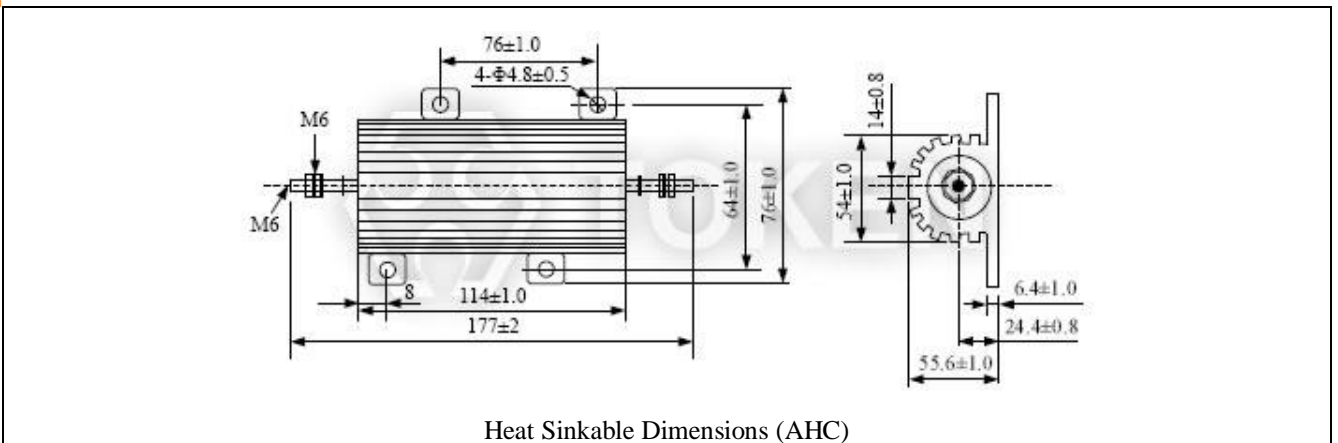

▶ AHS Electrical Spec.

Standard Electrical Specification (AHS)

Type	MIL Style	Wattage Rating (W)	Resistance Range (Ω)		Resistance Tolerance (%)		Max. Working (V)		Max. Weight (g)t	Proper heat sink (Aluminum chassis)	
			AHS Inductive	AHSN Non-inductive	AHS	AHSN	AHS	AHSN		Area (cm2)	Thickness (mm)
AHS-5	RE60	5	0.01R~3K	0.01R~750R	B (±0.1%) C (±0.25%) D (±0.5%) F (±1%) G (±2%) J (±5%) K (±10%)	F (±1%) G (±2%) J (±5%) K (±10%)	$\sqrt{(P * R)}$	3	415	1	
AHS-10	RE65	10	0.01R~5K	0.01R~1K25				6	415		
AHS-25	RE70	25	0.01R~10K	0.01R~2K				11	535		
AHS-30		30	0.01R~10K	0.01R~2K				18	535		
AHS-50	RE75	50	0.01R~10K	0.01R~2K				30	995	3	
AHS-75		75	0.01R~20K	0.5R~5K				90	995		
AHS-100	RE77	100	1R~30K	1R~7K				265	2780		
AHS-150		150	1R~40K	1R~10K				265	995		
AHS-200		200	1R~50K	1R~12K				420	3750		
AHS-250	RE80	250	1R~50K	1R~12K				510	4900		
AHS-250F	RE80	250	1R~50K	1R~12K				480	4765		
AHS-300		300	1R~50K	1R~12K				580	5780		
AHS-500		500	1R~50K	1R~12K				970	8500		

▶ AHC Electrical Spec.

Standard Electrical Specification (AHC)

Type	MIL Style	Wattage Rating (W)	Resistance Range (Ω)		Resistance Tolerance (%)		Max. Working (V)		Max. Weight (g)t	Proper heat sink (Aluminum chassis)	
			AHC Inductive	AHCN Non-inductive	AHC	AHCN	AHC	AHCN		Area (cm2)	Thickness (mm)
AHC-5	RE60	5	0.1R~3K	0.1R~750R	B (±0.1%) C (±0.25%) D (±0.5%) F (±1%) G (±2%) J (±5%) K (±10%)	F (±1%) G (±2%) J (±5%) K (±10%)	$\sqrt{(P * R)}$	6	415	1	
AHC-10	RE65	10	0.1R~5K	0.1R~1K25				11	415		
AHC-25	RE70	25	0.1R~10K	0.1R~2K				20	535		
AHC-50	RE75	50	0.1R~10K	0.1R~2K				30	995		
AHC-80		75	0.1R~20K	0.5R~5K				90	995	3	
AHC-100S		100	1R~30K	1R~7K				160	2780		
AHC-100	RE77	100	1R~3K	1R~3K				100	995		
AHC-250	RE80	250	1R~3K	1R~3K				480	4900		
AHC-300		300	1R~3K	1R~3K				580	5780		

► Heat-Sink & Derating Curve

Surface Temperature Versus Power Load (Mounted on heat-sink chassis) (AH)

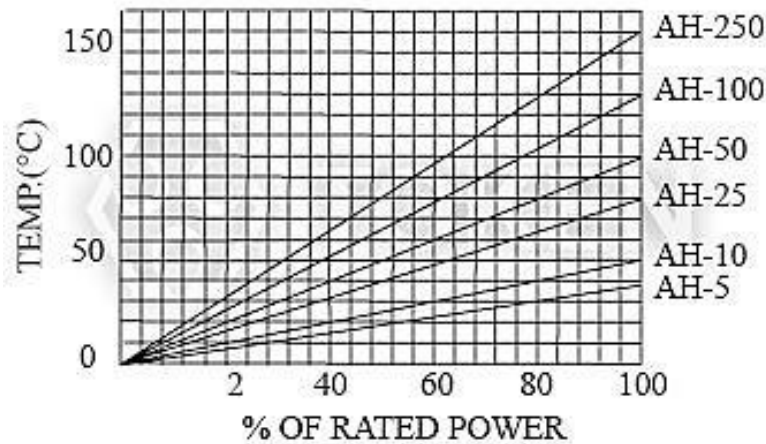

(AH) Surface Temperature Versus Power Load

Ambient Temperature Derating (AH)

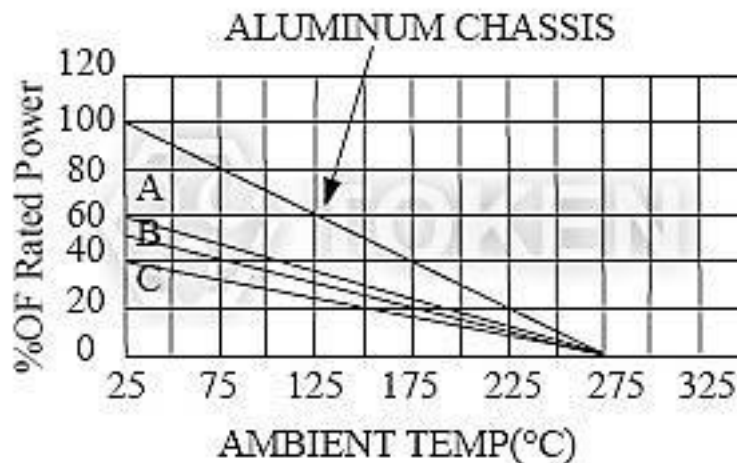

(AH) Ambient Temperature Derating

Derating is required for ambient temperatures above 25°C, see the graph.

Curve Aluminum Chassis applies to all types when mounted to specified heat sink.

Curves A, B, C applies to operation of unmounted resistors.

- Curves A: AH 5 and 10 watt unites, unmounted.
- Curves B: AH 25 watt units, unmounted.
- Curves C: AH 50, 100 and 250 watt units, unmounted.

Reduced Heat Sink Derating (AH)

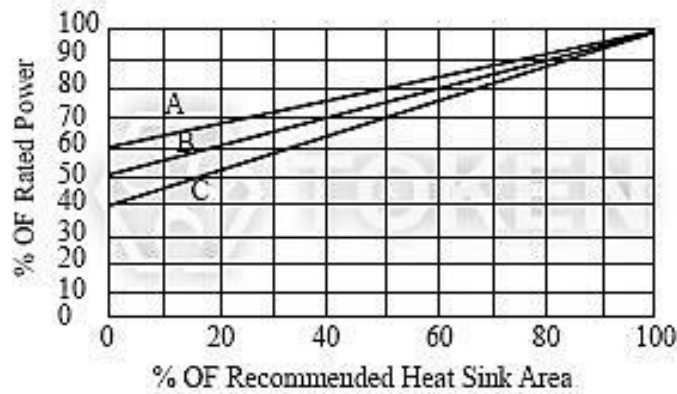

(AH) Reduced Heat Sink Derating

Derating is also required when recommended heat sink area is reduced.

- Curves A: AH-5 and AH-10 size resistor.
- Curves B: AH-25 size resistor.
- Curves C: AH-50, AH-100 and AH-250 size resistor.

Test Conditions

Test Conditions (AH)

Parameters	Test Conditions	Specifications
T.C.R.	Room temperature /100°C up.	±25, 50, 100, 250ppm/°C
Short Time Over Load	5 × wattage rating-5sec.	Δ R±(2%+0.05Ω)Max.
Vibration	10~50~10Hz/Min -X- Y- Z Axis 2 Hours each.	Δ R±(0.2%+0.05Ω)Max.
Load Life	Load Rating (chassis mounted) (1.5 Hour on 0.5 Hour OFF) Repeat 1000 Hours	Δ R±(5%+0.05Ω)Max.
Terminal Strength	(1) Pull Test (30 sec Min) AH-5: 1kg, AH-10: 2.3kg, AH-25, AH-50: 4.5kg (2) Torque Test (5~15sec) AH-100: 27kg-cm, AH-250: 36kg-cm	Δ R±(0.2%+0.05Ω)Max.
Dielectric Strength	AHS-5 AHS-10 AHS-25 1000V AHS-30, AHS-50, AHS-75, AHS-100 2000V AHS-150, AHS-200, AHS-250, AHS-300, AHS-500 2500V	Δ R±(0.5%+0.05Ω)Max.
	AHC-5 AHC-10 AHC-25 800V AHC-50, AHC-80, AHC-100 1000V AHC-250, AHC-300 2500V	
Insulation Resistance	Under the same test condition of Dielectric Strength, Load DC500V and measure the Insulation R.	AHS: 1000 MΩ Min. AHC: 100 MΩ Min.
Moisture Resistance	Temp 40°C moisture 95% DC 100V 100 Hrs.	Δ R±(5%+0.05Ω)Max.
Moisture Load Life	Temp 40°C moisture 90% 1/10 X wattage rating (1.5hrs on-0.5hrs off)-Repeat 200 Hrs.	Δ R±(5%+0.05Ω)Max.
Resistance to Soldering Heat	350°C ± 10°C for 3±0.5 Seconds	Δ R±(1%+0.05Ω)Max.

Order Codes

Order Codes (AH)

AH	S	10		20Ω		D	
Part Number	Encapsulant	Rated Power (W)		Resistance Value (Ω)		Resistance Tolerance (%)	
	S: Silicone	10	10W	R51	0.51Ω	B	±0.10%
	C: Cement	10N	10W	5R1	5.1Ω	C	±0.25%
		250	250W	51R	51Ω	D	±0.5%
		250N	250W	510R	510Ω	F	±1%
		N	Non-Inductive	5K1	5.1KΩ	G	±2%
						J	±5%
						K	±10%

► General Information

Benefits & Features

Providing design engineers with an economical resistor with high quality performance, Token Electronics offers industry grade power wire wound devices.

Token provide terminal blocks, thermal switches, fusing, fans, junction boxes, screened or solid bottom plates, conduit knockouts, and customer specified requirements. For large applications a welded frame construction is utilized to provide a robust design for power resistor mounting in both indoor and outdoor environments.

Products range from large capacity metal clad, nonflammable fixed and adjustable, wave ribbon wire-wound, slide, starter, box type, to nonflammable flat type. Token extends a complete line for both military and commercial applications.

Utilization Notes

1. Smoke emitted from non-flammable resistors on initial use in powered circuits is a normal phenomenon and the component can be safely utilized.
2. All resistors manufactured by Token Electronics Industry Corporation comply with the U.S. UL-94 non- flammability test, Class V-0, a continuous combustion period of zero seconds.
3. Never use organic solvents to clean non-flammable resistors.
4. Non-flammable resistors cannot be utilized in oil.
5. Non-flammable resistors cannot be used in high frequency machinery because of the inductance produced by the windings. A suitable type of resistor must be selected. Contact us for details.
6. In applications where resistors are subject to intermittent current surges and spikes, be sure in advance that the components selected are capable of withstanding brief durations of increased load.
7. Do not exceed the recommended usable load. Resistors must use within the rated voltage range to prevent the shortening of service life and/or failure of the wound resistance elements.
8. Minimum load. Resistors must be utilized at 1/10 or more of the rated voltage to prevent poor conductance due to oxidation build-up.
9. Although the hardness exceeds that of a 3H pencil lead, do not nick the resistor coating with screw drivers or other pointed objects.
10. Avoid touching non-flammable resistors in operation; the surface temperature ranges from approximately 350°C ~ 400°C when utilized at the full rated value. Maintaining a surface temperature of 200°C or less will extend resistor service life.
11. Keep temperature from rising by choosing a resistor with a higher rated capacity; do not use a component having the exact load value required. For considerations of safety in extended period applications, the resistor rating should be more than four times higher than the actual wattage involved, but never use a resistor at less than 25% of its rated power.
12. Application and Placement: Wire-wound resistors use different gauges of wire as resistance elements. Sometimes the gauge is extremely thin (finer than a strand of human hair) and very susceptible to breakage in environments containing salts, ash, dust and corrosives. Avoid utilization in such environments. Do not install in dusty areas because the accumulation will cause shorts and poor conductance.

