

Version:  
February 17, 2017



**(TREM)**  
**High SRFs**  
**RF Inductor**

**Token Electronics Industry Co., Ltd.**

**Taiwan:** No.137, Sec. 1, Zhongxing Rd., Wugu District,  
New Taipei City, Taiwan, R.O.C. 24872  
**Tel:** +886 2981 0109    **Fax:** +886 2988 7487

**China:** 12F, Zhong Xing Industry Bld., Chuang Ye Road,  
Nan Shan District, Shen Zhen City,  
Guang Dong, China 518054  
**Tel:** +86 755 26055363; **Fax:** +86 755 26055365

[Web: www.token.com.tw](http://www.token.com.tw)

[Email: rfq@token.com.tw](mailto:rfq@token.com.tw)



## ▶ Product Introduction

### Narrow Pad Chip Wire Wound Inductors with High SRFs for RF Applications.

#### Features :

- Metal terminals with excellent connection reliability.
- Accurate dimensions for automatically surface mounted.
- Lead-free materials is used for the plating on the terminals.
- High resistance to heat, humidity, mechanical shocks and presser.
- Good heat durability that withstands lead-free compatible reflow soldering conditions.

#### Applications :

- (TREM) series is suited for communication, video & audio, equipment, instrument which have been developed in response to the trend toward higher density mounting of parts in electric circuits.

#### Operating Temperature:

- Range: -25 ~ +85 °C.

Token (TREM) Series is primarily designed for chip narrow pad, high SRFs, molded type, wire wound inductors and offers improved performance in the same compact case size. Product conforms to the RoHS directive and Lead-free. The (TREM) series chip RF inductor can be customized designs for tighter tolerances on request.

Contact us with your specific needs. For more information, please link to Token official website "[RF Inductors](http://www.token.com.tw)".

#### A Brief Introduction to the Product:

SMT Inductors EM322522N and EM453232N series are revolutionary, high reliable wire wound components for communication, equipment, instruments, video & audio have been developed in response to the trend toward higher density mounting of inductor parts in electric circuits.



## Config. & Dim.

### Configurations & Dimensions (Unit: mm) (REM322522N, TREM453232N)

Type	A	B	C	D	E	F
TREM322522N(1210)	$3.2 \pm 0.4$	$2.5 \pm 0.2$	$2.9 \pm 0.3$	$2.2 \pm 0.2$	$0.6 \pm 0.2$	$1.0 \pm 0.2$
TREM453232N(1812)	$4.5 \pm 0.4$	$3.2 \pm 0.2$	$4.2 \pm 0.3$	$3.2 \pm 0.2$	$1.0 \pm 0.2$	$1.2 \pm 0.2$

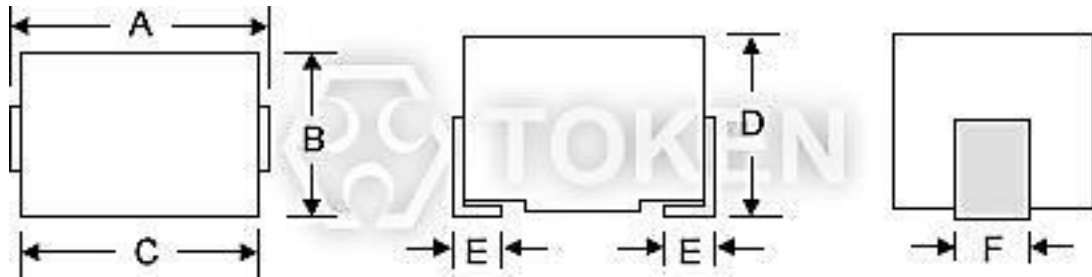

RF Narrow Pad Surface Mount (TREM) Dimensions

## Reel & Packaging

### Reel & Packaging (TREM322522N, TREM453232N)

TYPE	A	B	C	D	G	N	T
8mm	178	$21.0 \pm 0.8$	$13.0 \pm 0.5$	8	10 max	50 min	14.4 max
12mm	178	$21.0 \pm 0.8$	$13.0 \pm 0.5$	10	14 max	50 min	14.4 max

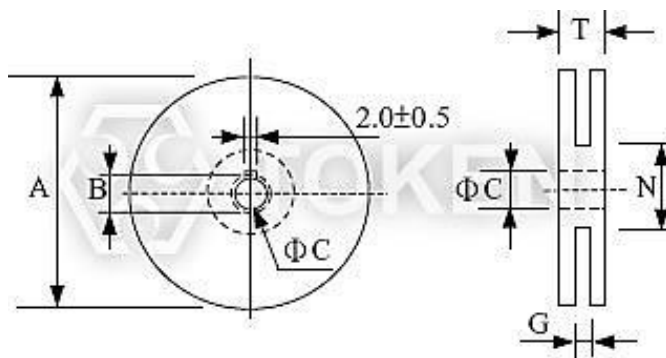

Reel Dimensions

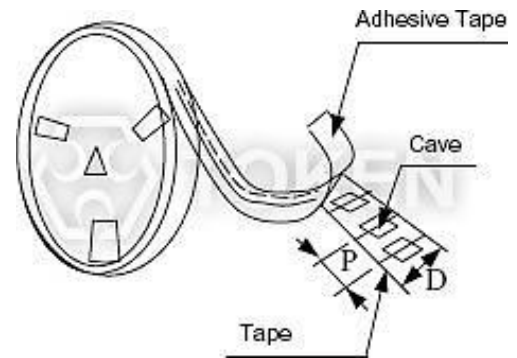

Tape Packing Dimensions

## Electrical Characteristics

### Electrical Characteristics (TREM322522N) - EIA 1210

Part No.	Inductance (μH)	Tolerance (%)	Q (min)	Test Freq. (MHZ)	SRF (MHZ)(min)	DCR (Ω)(max)	IDC (mA)
TREM322522N - R10*	0.10	±20,±10	28	100	700	0.44	450
TREM322522N - R12*	0.12	±20,±10	30	25.2	500	0.22	450
TREM322522N - R15*	0.15	±20,±10	30	25.2	450	0.25	450
TREM322522N - R18*	0.18	±20,±10	30	25.2	400	0.28	450
TREM322522N - R22*	0.22	±20,±10	30	25.2	350	0.32	450
TREM322522N - R27*	0.27	±20,±10	30	25.2	320	0.36	450
TREM322522N - R33*	0.33	±20,±10	30	25.2	300	0.40	450
TREM322522N - R39*	0.39	±20,±10	30	25.2	250	0.45	450
TREM322522N - R47*	0.47	±20,±10	30	25.2	220	0.50	450
TREM322522N - R56*	0.56	±20,±10	30	25.2	180	0.55	450
TREM322522N - R68*	0.68	±20,±10	30	25.2	160	0.60	450
TREM322522N - R82*	0.82	±20,±10	30	25.2	140	0.65	450
TREM322522N - 1R0*	1.00	±10,±5	30	7.96	120	0.70	400
TREM322522N - 1R2*	1.20	±10,±5	30	7.96	100	0.75	390
TREM322522N - 1R5*	1.50	±10,±5	30	7.96	85	0.85	370
TREM322522N - 1R8*	1.80	±10,±5	30	7.96	80	0.90	350
TREM322522N - 2R2*	2.20	±10,±5	30	7.96	75	1.00	320
TREM322522N - 2R7*	2.70	±10,±5	30	7.96	70	1.10	290
TREM322522N - 3R3*	3.30	±10,±5	30	7.96	60	1.20	260
TREM322522N - 3R9*	3.90	±10,±5	30	7.96	55	1.30	250
TREM322522N - 4R7*	4.70	±10,±5	30	7.96	50	1.50	220
TREM322522N - 5R6*	5.60	±10,±5	30	7.96	45	1.60	200
TREM322522N - 6R8*	6.80	±10,±5	30	7.96	40	1.80	180
TREM322522N - 8R2*	8.20	±10,±5	30	7.96	35	2.00	170
TREM322522N - 100*	10.0	±10,±5	30	2.52	30	2.10	150
TREM322522N - 120*	12.0	±10,±5	30	2.52	20	2.50	140
TREM322522N - 150*	15.0	±10,±5	30	2.52	20	2.80	130
TREM322522N - 180*	18.0	±10,±5	30	2.52	20	3.30	120
TREM322522N - 220*	22.0	±10,±5	30	2.52	20	3.70	110
TREM322522N - 270*	27.0	±10,±5	30	2.52	20	5.00	80
TREM322522N - 330*	33.0	±10,±5	30	2.52	17	5.60	70
TREM322522N - 390*	39.0	±10,±5	30	2.52	16	6.40	65
TREM322522N - 470*	47.0	±10,±5	30	2.52	15	7.00	60
TREM322522N - 560*	56.0	±10,±5	30	2.52	13	8.00	55
TREM322522N - 680*	68.0	±10,±5	30	2.52	12	9.00	50
TREM322522N - 820*	82.0	±10,±5	30	2.52	11	10.0	45
TREM322522N - 101*	100	±10,±5	20	0.796	10	10.0	40
TREM322522N - 121*	120	±10,±5	20	0.796	10	11.0	70
TREM322522N - 151*	150	±10,±5	20	0.796	8	15.0	65
TREM322522N - 181*	180	±10,±5	20	0.796	7	17.0	60
TREM322522N - 221*	220	±10,±5	20	0.796	7	21.0	50

- Note: Test equipment L, Q: HP4285A +16034E, or equivalent  
SRF: HP8753C NETWORK ANALYZER, or equivalent.  
DC resistance: AX-111A DIGITAL MILLIOHM METER, or equivalent.

## Electrical Characteristics (TREM453232N) - EIA 1812 -

Part No.	Inductance (μH)	Tolerance (%)	Q (min)	Test Freq. (MHZ)	SRF (MHz)(min)	DCR (Ω)(max)	IDC (mA)
TREM453232N - R10*	0.10	±10,±20	25	25.2	300	0.18	800
TREM453232N - R12*	0.12	±10,±20	30	25.2	280	0.20	770
TREM453232N - R15*	0.15	±10,±20	30	25.2	250	0.22	730
TREM453232N - R18*	0.18	±10,±20	30	25.2	220	0.24	700
TREM453232N - R22*	0.22	±10,±20	30	25.2	200	0.25	665
TREM453232N - R27*	0.27	±10,±20	30	25.2	180	0.26	635
TREM453232N - R33*	0.33	±10,±20	30	25.2	165	0.28	605
TREM453232N - R39*	0.39	±10,±20	30	25.2	150	0.30	575
TREM453232N - R47*	0.47	±10,±20	30	25.2	145	0.32	545
TREM453232N - R56*	0.56	±10,±20	30	25.2	140	0.36	520
TREM453232N - R68*	0.68	±10,±20	30	25.2	135	0.40	500
TREM453232N - R82*	0.82	±10,±20	30	25.2	130	0.45	475
TREM453232N - 1R0*	1.00	±10,±20	40	7.96	100	0.50	450
TREM453232N - 1R2*	1.20	±10,±20	40	7.96	80	0.55	430
TREM453232N - 1R5*	1.50	±10,±20	40	7.96	70	0.60	410
TREM453232N - 1R8*	1.80	±10,±20	40	7.96	60	0.65	390
TREM453232N - 2R2*	2.20	±10,±20	40	7.96	55	0.70	380
TREM453232N - 2R7*	2.70	±10,±20	40	7.96	50	0.75	370
TREM453232N - 3R3*	3.30	±10,±20	40	7.96	45	0.80	355
TREM453232N - 3R9*	3.90	±10,±20	40	7.96	40	0.90	330
TREM453232N - 4R7*	4.70	±10,±20	40	7.96	35	1.00	315
TREM453232N - 5R6*	5.60	±10,±20	40	7.96	33	1.10	300
TREM453232N - 6R8*	6.80	±10,±20	40	7.96	27	1.20	285
TREM453232N - 8R2*	8.20	±5,±10	40	7.96	25	1.40	270
TREM453232N - 100*	10.0	±5,±10	40	2.52	20	1.60	250
TREM453232N - 120*	12.0	±5,±10	40	2.52	18	2.00	225
TREM453232N - 150*	15.0	±5,±10	40	2.52	17	2.50	200
TREM453232N - 180*	18.0	±5,±10	40	2.52	15	2.80	190
TREM453232N - 220*	22.0	±5,±10	40	2.52	13	3.20	180
TREM453232N - 270*	27.0	±5,±10	40	2.52	12	3.60	170
TREM453232N - 330*	33.0	±5,±10	40	2.52	11	4.00	160
TREM453232N - 390*	39.0	±5,±10	40	2.52	10	4.50	150
TREM453232N - 470*	47.0	±5,±10	40	2.52	10	5.00	140
TREM453232N - 560*	56.0	±5,±10	40	2.52	9	5.50	135
TREM453232N - 680*	68.0	±5,±10	40	2.52	9	6.00	130
TREM453232N - 820*	82.0	±5,±10	40	2.52	8	7.00	120
TREM453232N - 101*	100	±5,±10	30	0.796	8	8.00	110
TREM453232N - 121*	120	±5,±10	30	0.796	6	8.00	110
TREM453232N - 151*	150	±5,±10	30	0.796	5	9.00	105
TREM453232N - 181*	180	±5,±10	30	0.796	5	9.50	102
TREM453232N - 221*	220	±5,±10	30	0.796	4	10.0	100
TREM453232N - 271*	270	±5,±10	30	0.796	4	12.0	92
TREM453232N - 331*	330	±5,±10	30	0.796	3.5	14.0	85
TREM453232N - 391*	390	±5,±10	30	0.796	3	18.0	80
TREM453232N - 471*	470	±5,±10	30	0.796	3	26.0	62
TREM453232N - 561*	560	±5,±10	20	0.796	3	30.0	50
TREM453232N - 681*	680	±5,±10	20	0.796	3	30.0	50
TREM453232N - 821*	820	±5,±10	20	0.796	2.5	35.0	30
TREM453232N - 102*	1000	±5,±10	10	0.252	2.5	40.0	30

- Note: Test equipment L, Q: HP4285A +16034E, or equivalent  
SRF: HP8753C NETWORK ANALYZER, or equivalent.  
DC resistance: AX-111A DIGITAL MILLIOHM METER, or equivalent.



## ► Characteristics

### Mechanical Performance Test (TREM322522N, TREM453232N)

REQUIREMENTS	CHARACTERISTICS	TEST METHOD(DIS C 5321)
Terminal Strength	No evidence of damage	Terminals shall withstand a pull of 0.5Kgf in a horizontal direction
Vibration	$\Delta$ L/L shall be within $\pm 3\%$ . No evidence of damage	2 hours in each direction of X,Y,Z on p-Board at a frequency range of 10-55-10HZ with 1.5mm amplitude
Dropping	$\Delta$ L/L shall be within $\pm 3\%$ . No evidence of damage	Dropping 1m over the ground of concrete or cement

### TREM322522N, TREM453232N Series RF Chip Wire wound Inductors - Electrical Performance Test

REQUIREMENTS	CHARACTERISTICS	TEST METHOD(JIS C 5321)
Resistance to Soldering Heat	No evidence of damage $\Delta$ L/L shall be within $\pm 3\%$	Immerse in the solder (H63A) of $260 \pm 5^\circ\text{C}$ for $10 \pm 1$ sec, leave for 2hrs at normal TEMP
Solderability	More than 90% surface to be covered with new soldering	AV100V 60 SEC.
Dielectric with withstanding voltage	No evidence of breakdown resistor 1000 Mohm and over	DC500V 30 SEC.
Insulation Resistance	No evidence of breakdown, resistor 1000 Mohm and over	DC 500V 30 SEC.

### Climatic Test (TREM322522N, TREM453232N)

REQUIREMENTS	CHARACTERISTICS	TEST METHOD(JIS C 5321)
LOW TEMP. Characteristics	No evidence of damage, $\Delta$ L/L within $\pm 5\%$ , Q/Q within $\pm 30\%$	Immerse in the solder (H63A) of $260 \pm 5^\circ\text{C}$ for $10 \pm 1$ sec, leave for 2hrs at normal TEMP.
TEMP. Cycling	No evidence of damage, $\Delta$ L/L within $\pm 5\%$	Keep for 30 min. at TEMP. of $-25^\circ\text{C} \sim +85^\circ\text{C}$ at 5 cycle case of TEMP. change from low to high and V.V.
Temperature Characteristics	$\Delta$ L/L within $\pm 3\%$	$\Delta$ L/L to be measured at the temperature of between $-25^\circ\text{C}$ and $+85^\circ\text{C}$
Moisture load Characteristics	No evidence of damage, $\Delta$ L/L within $\pm 5\%$ , Q/Q within $\pm 30$	TEMP. $40 \pm 2^\circ\text{C}$ , Humidity 90~95% $96 \pm 2$ hrs, measurements shall be performed after 1~2hrs at normal TEMP.
High TEMP. overload Characteristics	No evidence of damage, $\Delta$ L/L within $\pm 5\%$ , Q/Q within $\pm 30$	Leave for $96 \pm 2$ hrs in a bath of TEMP. $85 \pm 2^\circ\text{C}$ , measurements shall be performed after 1~2hrs at normal TEMP.

## Order Codes

### Order Codes (TREM322522N, TREM453232N)

TCEC322522N	-	1R0		M	
Part Number		Inductance		Tolerance	
TREM322522N		R10	0.10 $\mu$ H	J	5%
TREM453232N		1R0	1.00 $\mu$ H	K	10%
		100	10.00 $\times 10^0\mu$ H	M	20%
		101	10.00 $\times 10^1\mu$ H		
		102	10.00 $\times 10^2\mu$ H		
		103	10.00 $\times 10^3\mu$ H		



## ► General Information

### Token Cuts Inductor Size and Cost

Token utilizes the latest technology enabling the most cost-effective designs in manufacturing inductors. The 0402, 0603, 0805, 1206, 1210, to 1812 series of RF Miniature Inductors all contain wire wound or multi-layer technology with material substrate in ceramic or ferrite cores. Thus providing economic cost with the ultimate performance demanded by today's RF applications. Inductors feature high Q factor, SRFs (self-resonant or series resonant frequency), and  $I_{dc}$  (maximum current carrying capacity).

### How to quickly search RF inductors for all of the characteristics?

Searching and comparing data sheets of inductor manufacturers can be time consuming. Token's Parameter Sorting Search Mode allows selection of inductors based on different parameters. To enter Searching Mode:

- By entering just the inductance value,
- By sorting parameter to narrow down searching range,
- Or by enter keyword / part number / size dimensions L\*W\*H to partial or exact searching.

### Inductors Selection Notes:

**For choke applications**, the SRFs (self-resonant or series resonant frequency) is the frequency that provides the best signal blocking.

- At the SRF, impedance is at its maximum.
- At frequencies below the SRF, impedance increases with frequency.
- At frequencies above the SRF, impedance decreases with frequency.

**For higher order filter or impedance matching applications**, in general, the choice of inductance value typically determines the SRF and vice versa. The higher the inductance value, the lower the SRF, due to increased winding capacitance. It is more important to have a relatively flat inductance curve (constant inductance vs. frequency) near the required frequency. This suggests selecting an inductor with an SRF well above the design frequency. A rule of thumb is to select an inductor with an SRF that is a decade (10X) higher than the operating frequency.

**What is Q factor?** High Q leads to low insertion loss, minimizing power consumption, and narrow bandwidth. It is important if the inductor is to be used as part of an LC (oscillator) circuit or in narrow band pass applications. In general, wire wound inductors have much higher Q values than multilayer inductors of the same size and value. Token's material science and manufacturing expertise effectively bridges the gap between wire-wound performance and multi-layer inductors with its TRMF100505 (EIA 0402) and TRMI160808 (EIA 0603) series.

**How does current requirement affect inductor?** Higher current requires larger wire or more threads of the same wire size to keep losses and temperature rise to a minimum. Larger wire lowers the DCR and increases the Q factor. Using a ferrite core inductor with a lower turn count can achieve higher current capacity and lower DCR. Ferrite, however, may introduce new limitations such as larger variation of inductance with temperature, looser tolerances, lower Q, and reduced saturation current ratings. Token's ferrite inductors with open magnetic structures, will not saturate, even at full rated current.

