

Version:
February 17, 2017



(TRCM)
Wire Wound
RF SMD Inductor

Token Electronics Industry Co., Ltd.

Taiwan: No.137, Sec. 1, Zhongxing Rd., Wugu District,
New Taipei City, Taiwan, R.O.C. 24872
Tel: +886 2981 0109 **Fax:** +886 2988 7487

China: 12F, Zhong Xing Industry Bld., Chuang Ye Road,
Nan Shan District, Shen Zhen City,
Guang Dong, China 518054
Tel: +86 755 26055363; **Fax:** +86 755 26055365

[Web: www.token.com.tw](http://www.token.com.tw)

[Email: rfq@token.com.tw](mailto:rfq@token.com.tw)



▶ Product Introduction

RF Chip Wire wound inductors

Go To Extremes Superior Performance.

Features :

- High resistance to heat and humidity.
- Resistant to mechanical shocks and pressures.
- Accurate dimensions for automatically surface mounted.
- Good heat durability that withstands lead-free compatible reflow soldering conditions.

Materials:

- Ferrite DR core, enamelled copper wire, tinned copper flat, epoxy novolac moldind compound

Applications :

- Other electronic equipment including HDDs and ODDs.
- Audio-visual equipment including TVs, VCRs and digital cameras.
- Electronic equipment used in onboard automobile equipment including car audio and ECU systems.
- Electronic equipment used in communication infrastructures including xDSL and mobile base stations.

Miniaturization of today's electrical and electronic devices requires component manufacturers to increase the performance of components without increasing footprint. Token (TRCM) series utilities wire wound technology that offers wide Pad inductor with the highest SRF carrying capability, highest usable frequency range, and the best Q factor of the narrow pad (TREM) and (TREC) series.

The latest wire wound chip inductor (TRCM) series offers improved performance in the same compact molded case size. These series conform to the RoHS directive and Lead-free. Custom parts are available on request. Token will also produce devices outside these specifications to meet specific customer requirements, please contact our sales or link to Token official website "[RF Inductors](http://www.token.com.tw)" for more information.

A Brief Introduction to the Product:

SMD Inductors CM322522 and CM453232 series are revolutionary, high reliable wire wound components for communication, equipment, instruments, video & audio have been developed in response to the trend toward higher density mounting of inductor parts in electric circuits.



Config. & Dim.

Configurations & Dimensions (Unit: mm) (TRCM)

Type	A	B	C	D	E	F	G	H
TRCM322522(1210)	3.2 ± 0.3	2.5 ± 0.2	2.2 ± 0.2	$0.4^{+0.1}_0$	1.9 ± 0.1	3.0	1.0	2.0
TRCM453232(1812)	4.5 ± 0.3	3.2 ± 0.2	3.2 ± 0.2	$0.4^{+0.1}_0$	2.6 ± 0.1	4.0	1.5	3.0

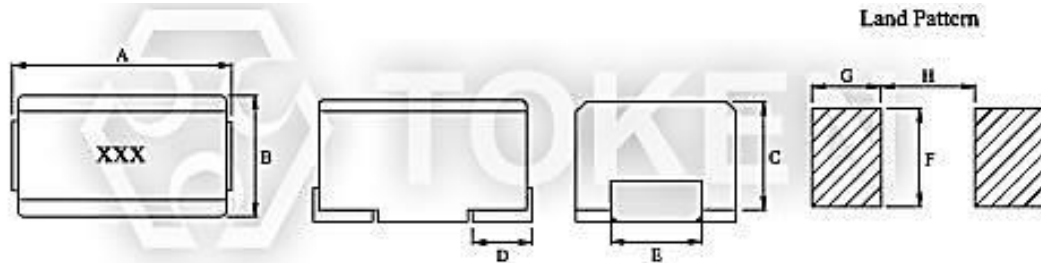

RF Surface Mount (TRCM Series) Land Pattern and Dimensions

Reel & Packaging

Reel & Packaging (Unit: mm) (TRCM)

TYPE	A	B	C	D	G	N	T
8mm	178	21.0 ± 0.8	13.0 ± 0.5	8	10 max	50 min	14.4 max
12mm	178	21.0 ± 0.8	13.0 ± 0.5	10	14 max	50 min	14.4 max

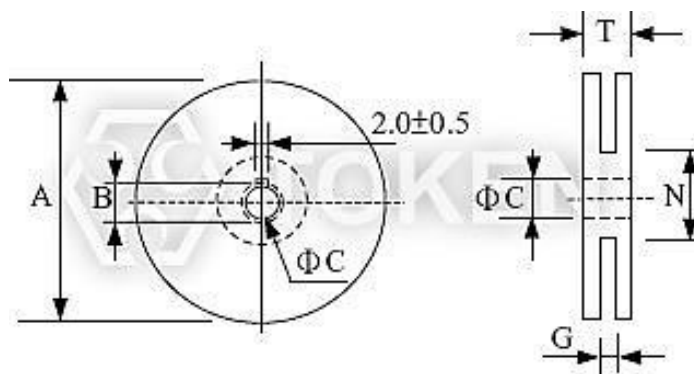

Reel Dimensions

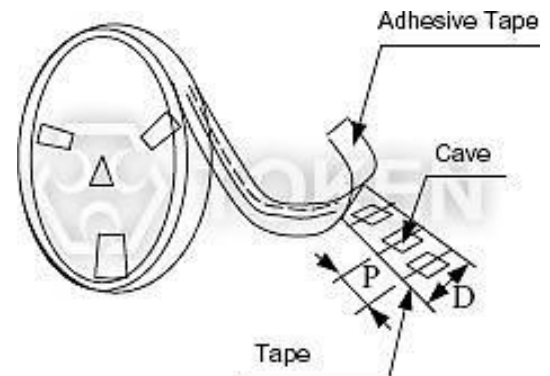

Tape Packing Dimensions

Electrical Characteristics

Standard Electrical Characteristics (TRCM322522) - EIA 1210

Part No.	Inductance (μH)	Q (min)	Test Freq. (MHZ)	SRF (MHz)(min)	DCR (Ω)(max)	IDC (mA)
TRCM322522 - 010J	0.01 ± 5%	15	100	2500	0.13	450
TRCM322522 - 012J	0.012 ± 5%	17	100	2300	0.14	450
TRCM322522 - 015J	0.015 ± 5%	19	100	2100	0.16	450
TRCM322522 - 018J	0.018 ± 5%	21	100	1900	0.18	450
TRCM322522 - 022J	0.022 ± 5%	23	100	1700	0.2	450
TRCM322522 - 027J	0.027 ± 5%	23	100	1500	0.22	450
TRCM322522 - 033J	0.033 ± 5%	25	100	1400	0.24	450
TRCM322522 - 039J	0.039 ± 5%	25	100	1300	0.27	450
TRCM322522 - 047J	0.047 ± 5%	26	100	1200	0.3	450
TRCM322522 - 056J	0.056 ± 5%	26	100	1100	0.33	450
TRCM322522 - 068J	0.068 ± 5%	27	100	1000	0.36	450
TRCM322522 - 082J	0.082 ± 5%	27	100	900	0.4	450
TRCM322522 - R10J	0.1 ± 5%	28	100	700	0.44	450
TRCM322522 - R12J	0.12 ± 5%	30	25.2	500	0.22	450
TRCM322522 - R15J	0.15 ± 5%	30	25.2	400	0.28	450
TRCM322522 - R18J	0.18 ± 5%	30	25.2	400	0.28	450
TRCM322522 - R22J	0.22 ± 5%	30	25.2	350	0.32	450
TRCM322522 - R27J	0.27 ± 5%	30	25.2	320	0.36	450
TRCM322522 - R33J	0.33 ± 5%	30	25.2	300	0.4	250
TRCM322522 - R39J	0.39 ± 5%	30	25.2	250	0.45	450
TRCM322522 - R47J	0.47 ± 5%	30	25.2	220	0.5	450
TRCM322522 - R56J	0.56 ± 5%	30	25.2	180	0.55	450
TRCM322522 - R68J	0.68 ± 5%	30	25.2	160	0.6	450
TRCM322522 - R82J	0.82 ± 5%	30	25.2	140	0.65	450
TRCM322522 - 1R0J	1 ± 5%	30	7.96	120	0.7	400
TRCM322522 - 1R2J	1.2 ± 5%	30	7.96	100	0.75	390
TRCM322522 - 1R5J	1.5 ± 5%	30	7.96	85	0.85	370
TRCM322522 - 1R8J	1.8 ± 5%	30	7.96	80	0.9	350
TRCM322522 - 2R2J	2.2 ± 5%	30	7.96	75	1	320
TRCM322522 - 2R7J	2.7 ± 5%	30	7.96	70	1.1	290
TRCM322522 - 3R3J	3.3 ± 5%	30	7.96	60	1.2	260
TRCM322522 - 3R9J	3.9 ± 5%	30	7.96	55	1.3	250
TRCM322522 - 4R7J	4.7 ± 5%	30	7.96	50	1.5	220
TRCM322522 - 5R6J	5.6 ± 5%	30	7.96	45	1.6	200
TRCM322522 - 6R8J	6.8 ± 5%	30	7.96	40	1.8	180
TRCM322522 - 8R2J	8.2 ± 5%	30	7.96	35	2	170
TRCM322522 - 100J	10 ± 5%	30	2.52	30	2.1	150
TRCM322522 - 120J	12 ± 5%	30	2.52	20	2.5	140
TRCM322522 - 150J	15 ± 5%	30	2.52	20	2.8	130
TRCM322522 - 180J	18 ± 5%	30	2.52	20	3.3	120
TRCM322522 - 220J	22 ± 5%	30	2.52	20	3.7	110



Part No.	Inductance (μH)	Q (min)	Test Freq. (MHZ)	SRF (MHz)(min)	DCR (Ω)(max)	IDC (mA)
TRCM322522 - 270J	27 ± 5%	30	2.52	20	5	80
TRCM322522 - 330J	33 ± 5%	30	2.52	17	5.6	70
TRCM322522 - 390J	39 ± 5%	30	2.52	16	6.4	65
TRCM322522 - 470J	47 ± 5%	30	2.52	15	7	60
TRCM322522 - 560J	56 ± 5%	30	2.52	13	8	55
TRCM322522 - 680J	68 ± 5%	30	2.52	12	9	50
TRCM322522 - 820J	82 ± 5%	30	2.52	11	10	45
TRCM322522 - 101J	100 ± 5%	20	0.796	10	10	40
TRCM322522 - 121J	120 ± 5%	20	0.796	10	11	70
TRCM322522 - 151J	150 ± 5%	20	0.796	8	15	65
TRCM322522 - 181J	180 ± 5%	20	0.796	7	17	60
TRCM322522 - 221J	220 ± 5%	20	0.796	7	21	50
TRCM322522 - 271J	270 ± 5%	20	0.796	6	28	45
TRCM322522 - 331J	330 ± 5%	20	0.796	5	34	40
TRCM322522 - 391J	390 ± 5%	20	0.796	5	36	35
TRCM322522 - 471J	470 ± 5%	20	0.796	4	40	25



Standard Electrical Characteristics (TRCM453232) - EIA 1812

Part No.	Inductance (μH)	Q (min)	Test Freq. (MHZ)	SRF (MHz)(min)	DCR (Ω)(max)	IDC (mA)
TRCM453232 - 1R0J	1 ± 5%	50	7.96	100	0.5	450
TRCM453232 - 1R2J	1.2 ± 5%	50	7.96	80	0.55	430
TRCM453232 - 1R5J	1.5 ± 5%	50	7.96	70	0.6	410
TRCM453232 - 1R8J	1.8 ± 5%	50	7.96	60	0.65	390
TRCM453232 - 2R2J	2.2 ± 5%	50	7.96	55	0.7	380
TRCM453232 - 2R7J	2.7 ± 5%	50	7.96	50	0.75	370
TRCM453232 - 3R3J	3.3 ± 5%	50	7.96	45	0.8	355
TRCM453232 - 3R9J	3.9 ± 5%	50	7.96	40	0.9	330
TRCM453232 - 4R7J	4.7 ± 5%	50	7.96	35	1	315
TRCM453232 - 5R6J	5.6 ± 5%	50	7.96	33	1.1	300
TRCM453232 - 6R8J	6.8 ± 5%	50	7.96	27	1.2	285
TRCM453232 - 8R2J	8.2 ± 5%	50	7.96	25	1.4	270
TRCM453232 - 100J	10 ± 5%	50	2.52	20	1.6	250
TRCM453232 - 120J	12 ± 5%	50	2.52	18	2	225
TRCM453232 - 150J	15 ± 5%	50	2.52	17	2.5	200
TRCM453232 - 180J	18 ± 5%	50	2.52	15	2.8	190
TRCM453232 - 220J	22 ± 5%	50	2.52	13	3.2	180
TRCM453232 - 270J	27 ± 5%	50	2.52	12	3.6	170
TRCM453232 - 330J	33 ± 5%	50	2.52	11	4	160
TRCM453232 - 390J	39 ± 5%	50	2.52	10	4.5	150
TRCM453232 - 470J	47 ± 5%	50	2.52	10	5	140
TRCM453232 - 560J	56 ± 5%	50	2.52	9	5.5	135
TRCM453232 - 680J	68 ± 5%	50	2.52	9	6	130
TRCM453232 - 820J	82 ± 5%	50	2.52	8	7	120
TRCM453232 - 101J	100 ± 5%	40	0.796	8	8	110
TRCM453232 - 121J	120 ± 5%	40	0.796	6	8	110
TRCM453232 - 151J	150 ± 5%	40	0.796	5	9	105
TRCM453232 - 181J	180 ± 5%	40	0.796	5	9.5	102
TRCM453232 - 221J	220 ± 5%	40	0.796	4	10	100
TRCM453232 - 271J	270 ± 5%	40	0.796	4	12	92
TRCM453232 - 331J	330 ± 5%	40	0.796	3.5	14	85
TRCM453232 - 391J	390 ± 5%	40	0.796	3	16	80
TRCM453232 - 471J	470 ± 5%	40	0.796	3	26	62
TRCM453232 - 561J	560 ± 5%	30	0.796	3	30	50
TRCM453232 - 681J	680 ± 5%	30	0.796	3	30	50
TRCM453232 - 821J	820 ± 5%	30	0.796	2.5	35	30
TRCM453232 - 102J	1000 ± 5%	30	0.252	2.5	40	30

► Performance Characteristics

Mechanical Performance Test (TRCM322522, TRCM453232)

REQUIREMENTS	CHARACTERISTICS	TEST METHOD(DIS C 5321)
Terminal Strength	No evidence of damage	Terminals shall withstand a pull of 0.5Kgf in a horizontal direction
Vibration	Δ L/L shall be within $\pm 3\%$. No evidence of damage	2 hours in each direction of X,Y,Z on p-Board at a frequency range of 10-55-10HZ with 1.5mm amplitude
Dropping	Δ L/L shall be within $\pm 3\%$. No evidence of damage	Dropping 1m over the ground of concrete or cement

Electrical Performance Test (TRCM322522, TRCM453232)

REQUIREMENTS	CHARACTERISTICS	TEST METHOD(JIS C 5321)
Resistance to Soldering Heat	No evidence of damage Δ L/L shall be within $\pm 3\%$	Immerse in the solder (H63A) of $260 \pm 5^\circ\text{C}$ for 10 ± 1 sec, leave for 2hrs at normal TEMP
Solderability	More than 90% surface to be covered with new soldering	AV100V 60 SEC.
Dielectric with withstanding voltage	No evidence of breakdown resistor 1000 Mohm and over	DC500V 30 SEC.
Insulation Resistance	No evidence of breakdown, resistor 1000 Mohm and over	DC 500V 30 SEC.

Climatic Test (TRCM322522, TRCM453232)

REQUIREMENTS	CHARACTERISTICS	TEST METHOD(JIS C 5321)
LOW TEMP. Characteristics	No evidence of damage, Δ L/L within $\pm 5\%$, Q/Q within $\pm 30\%$	Immerse in the solder (H63A) of $260 \pm 5^\circ\text{C}$ for 10 ± 1 sec, leave for 2hrs at normal TEMP.
TEMP. Cycling	No evidence of damage, Δ L/L within $\pm 5\%$	Keep for 30 min. at TEMP. of $-25^\circ\text{C} \sim +85^\circ\text{C}$ at 5 cycle case of TEMP. change from low to high and V.V.
Temperature Characteristics	Δ L/L within $\pm 3\%$	Δ L/L to be measured at the temperature of between -25°C and $+85^\circ\text{C}$
Moisture load Characteristics	No evidence of damage, Δ L/L within $\pm 5\%$, Q/Q within ± 30	TEMP. $40 \pm 2^\circ\text{C}$, Humidity 90~95% 96 ± 2 hrs, measurements shall be performed after 1~2hrs at normal TEMP.
High TEMP. overload Characteristics	No evidence of damage, Δ L/L within $\pm 5\%$, Q/Q within ± 30	Leave for 96 ± 2 hrs in a bath of $85 \pm 2^\circ\text{C}$, measurements shall be performed after 1~2hrs at normal TEMP.

Order Codes

Order Codes (TRCM322522, TRCM453232)

TRCM322522	-	R10	J
Part Number		Inductance	Tolerance
TRCM322522		R10 0.10μH	J 5%
TRCM453232		1R0 1.00μH	
		100 10.00×10 ⁰ μH	
		101 10.00×10 ¹ μH	
		102 10.00×10 ² μH	

▶ General Information

Token Cuts Inductor Size and Cost

Token utilizes the latest technology enabling the most cost-effective designs in manufacturing inductors. The 0402, 0603, 0805, 1206, 1210, to 1812 series of RF Miniature Inductors all contain wire wound or multi-layer technology with material substrate in ceramic or ferrite cores. Thus providing economic cost with the ultimate performance demanded by today's RF applications. Inductors feature high Q factor, SRFs (self-resonant or series resonant frequency), and I_{dc} (maximum current carrying capacity).

How to quickly search RF inductors for all of the characteristics?

Searching and comparing data sheets of inductor manufacturers can be time consuming. Token's Parameter Sorting Search Mode allows selection of inductors based on different parameters. To enter Searching Mode:

- By entering just the inductance value,
- By sorting parameter to narrow down searching range,
- Or by enter keyword / part number / size dimensions L*W*H to partial or exact searching.

Inductors Selection Notes:

For choke applications, the SRFs (self-resonant or series resonant frequency) is the frequency that provides the best signal blocking.

- At the SRF, impedance is at its maximum.
- At frequencies below the SRF, impedance increases with frequency.
- At frequencies above the SRF, impedance decreases with frequency.

For higher order filter or impedance matching applications, in general, the choice of inductance value typically determines the SRF and vice versa. The higher the inductance value, the lower the SRF, due to increased winding capacitance. It is more important to have a relatively flat inductance curve (constant inductance vs. frequency) near the required frequency. This suggests selecting an inductor with an SRF well above the design frequency. A rule of thumb is to select an inductor with an SRF that is a decade (10X) higher than the operating frequency.

What is Q factor? High Q leads to low insertion loss, minimizing power consumption, and narrow bandwidth. It is important if the inductor is to be used as part of an LC (oscillator) circuit or in narrow band pass applications. In general, wire wound inductors have much higher Q values than multilayer inductors of the same size and value. Token's material science and manufacturing expertise effectively bridges the gap between wire-wound performance and multi-layer inductors with its TRMF100505 (EIA 0402) and TRMI160808 (EIA 0603) series.

How does current requirement affect inductor? Higher current requires larger wire or more threads of the same wire size to keep losses and temperature rise to a minimum. Larger wire lowers the DCR and increases the Q factor. Using a ferrite core inductor with a lower turn count can achieve higher current capacity and lower DCR. Ferrite, however, may introduce new limitations such as larger variation of inductance with temperature, looser tolerances, lower Q, and reduced saturation current ratings. Token's ferrite inductors with open magnetic structures, will not saturate, even at full rated current.

