

Version:
June 27, 2017



TOKEN

(TPSH) Low DCR Low-Profile Power Inductors

Token Electronics Industry Co., Ltd.

Taiwan: No.137, Sec. 1, Zhongxing Rd., Wugu District,
New Taipei City, Taiwan, R.O.C. 24872
Tel: +886 2981 0109 Fax: +886 2988 7487

China: 12F, Zhong Xing Industry Bld., Chuang Ye Road,
Nan Shan District, Shen Zhen City,
Guang Dong, China 518054
Tel: +86 755 26055363; Fax: +86 755 26055365

[Web: www.token.com.tw](http://www.token.com.tw)

[Email: rfq@token.com.tw](mailto:rfq@token.com.tw)



▶ Product Introduction

Token's Low DCR Low-Profile Power Inductors fit into to more portable applications.

Features :

- Various high power inductors are superior to be high Saturation for surface mounting..
- Excellent solderability and high heat resistance.
- Magnetically shielded construction.

Applications :

- Power supply for VCRS; OA equipment Digital camera, LCD television set notebook PC, portable communication Equipments, DC/DC converters, etc..

Like many components in the industry, power wirewound inductors are being impacted by the trend toward smaller electronic devices with enhanced functionality requiring increased density of components on the board.

Token introduces low-profile, high-current inductor in case size. The TPSH series offers designers a high-current solution using a larger part, without exceeding a profile of 1.1 mm on either side of the PC board.

The miniaturization of battery-powered devices also requires more compact circuit-board designs, and therefore smaller but more-effective inductor designs. Token (TPSH) offers an inductance range from 1.0 μH to 1000.0 μH , and DCR from 0.009 Ω to 19.110 Ω .

The (TPSH) inductor serves as a high-performing, space-saving and power-saving solution for low-profile, high-current power supplies and point of load (POL) converters; distributed power systems; voltage regulator module (VRM) and DC-to-DC converter applications in end products including next-generation mobile devices; notebooks, desktop computers, personal multimedia devices, automotive systems, servers, graphic cards, portable gaming devices, and personal navigation systems; and field-programmable gate arrays (FPGAs).

This wire-wound inductor handles high transient current spikes without hard saturation. Packaged in an RoHS-compliant, 100 % lead (Pb)-free shielded, composite construction that reduces buzz noise to ultra-low levels, the new device is specified for an operating temperature range of -25°C to +125°C, with high resistance to mechanical shock, thermal shock, moisture, and vibration.

Custom parts are available on request. Token will also produce devices outside these specifications to meet specific customer requirements, Please contact our sales or link to Token official website "[SMD Power Inductors](http://www.token.com.tw)" for more information.



► Dimensions

Dimensions & Configurations (TPSH)

Type	A ± 0.3	B ± 0.3	C ± 0.3	D	E	F	G	H	I
TPSH6011	6.20	6.50	1.10	2.15	2.20	4.90	2.40	4.90	1.10
TPSH6011	6.20	6.50	1.10	2.15	2.20	4.90	2.40	4.90	1.10
TPSH6013	6.20	6.50	1.40	2.15	2.20	4.90	2.40	4.90	1.10
TPSH6018	6.20	6.50	1.80	2.15	2.20	4.90	2.40	4.90	1.10
TPSH6025	6.20	6.50	2.50	2.15	2.20	4.90	2.40	4.90	1.10
TPSH8028	6.20	6.50	2.50	2.15	2.20	4.90	2.40	4.90	1.10
TPSH8030	8.00	8.00	2.80	2.50	2.80	6.00	3.20	5.80	2.00
TPSH8040	8.00	8.00	3.80	2.40	3.20	6.40	3.40	6.20	1.40
TPSH8043	6.20	6.50	2.50	2.15	2.20	4.90	2.40	4.90	1.10
TPSH8045	8.00	8.00	4.30	2.50	3.00	6.00	3.20	5.80	1.40
TPSH8058	8.00	8.00	5.80	2.40	3.20	6.40	3.40	6.20	1.40
TPSH1028	10.0	10.0	2.80	3.40	3.20	7.40	4.00	7.20	1.80
TPSH1030	10.0	10.0	2.80	3.00	4.00	8.20	4.20	8.20	1.40
TPSH1038	10.0	10.0	3.80	3.40	3.20	7.40	4.00	7.20	1.80
TPSH1040	10.0	10.0	3.80	3.00	4.00	8.20	4.20	8.20	1.40
TPSH1050	10.0	10.0	4.80	3.00	4.00	8.20	4.20	8.20	1.40
TPSH1065	10.0	10.0	6.60	3.00	4.00	8.20	4.20	8.20	1.40

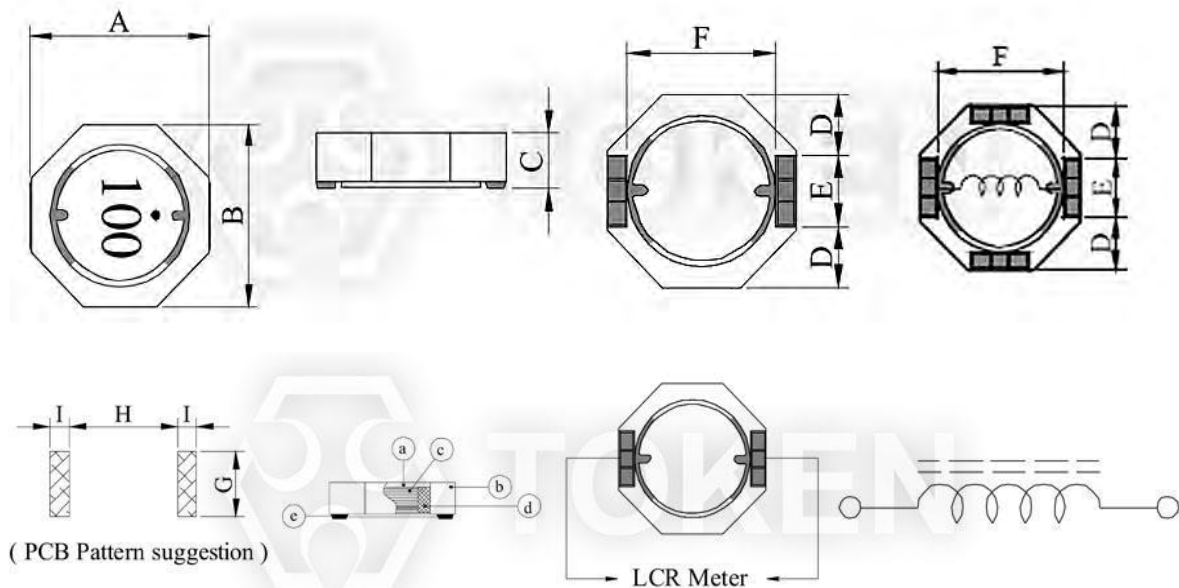

● Note: Design as Customer's Requested Specifications.



► **TPSH60**

Electrical Characteristics (TPSH6011)

Part NO	Inductance (μH)	Q Ref.	TEST Freq.		DCR (mΩ)		SRF (MHz) TYP.	Irms (mA) TYP.	Isat (mA) TYP.
			L	Q	TYP.	MAX.			
TPSH6011-1R4	1.4 ± 30%	8	100K	7.96M	30	40	140	2600	1800
TPSH6011-2R7	2.7 ± 30%	8	100K	7.96M	48	62	100	2200	1450
TPSH6011-4R7	4.7 ± 30%	8	100K	7.96M	66	86	70	1800	1100
TPSH6011-6R8	6.8 ± 30%	7	100K	7.96M	105	136	55	1400	900
TPSH6011-100	10.0 ± 30%	12	100K	2.52M	170	220	45	1100	720
TPSH6011-150	15.0 ± 30%	10	100K	2.52M	240	320	32	950	620
TPSH6011-220	22.0 ± 30%	10	100K	2.52M	300	390	26	800	480
TPSH6011-330	33.0 ± 30%	10	100K	2.52M	430	560	22	680	380
TPSH6011-470	47.0 ± 30%	10	100K	2.52M	650	850	20	550	320
TPSH6011-680	68.0 ± 30%	12	100K	2.52M	920	1200	18	460	280

Note:

- Measuring Frequency. L: 100KHz/0.25v.
- IDC: The current when the inductance becomes 35% lower than its nominal value. and temperature rise 40°C Δt = 40°C (ta = 20°C).

Electrical Characteristics (TPSH6013)

Part NO	Inductance (μH)	Q Ref.	TEST Freq.		DCR (mΩ)		SRF (MHz) TYP.	Irms (mA) TYP.	Isat (mA) TYP.
			L	Q	TYP.	MAX.			
TPSH6013-1R0	1.0 ± 30%	12	100K	7.96M	28	36	100	3200	2900
TPSH6013-1R5	1.5 ± 30%	10	100K	7.96M	32	40	90	3000	2400
TPSH6013-2R2	2.2 ± 30%	10	100K	7.96M	40	50	80	2500	2100
TPSH6013-3R3	3.3 ± 30%	10	100K	7.96M	45	60	70	2350	1750
TPSH6013-4R2	4.2 ± 30%	10	100K	7.96M	58	75	55	2100	1500
TPSH6013-6R4	6.4 ± 30%	10	100K	7.96M	85	110	45	1700	1300
TPSH6013-100	10.0 ± 30%	14	100K	2.52M	132	156	35	1400	1100
TPSH6013-150	15.0 ± 30%	12	100K	2.52M	180	235	26	1100	800
TPSH6013-220	22.0 ± 30%	12	100K	2.52M	260	325	22	950	720
TPSH6013-330	33.0 ± 30%	10	100K	2.52M	400	500	18	780	580
TPSH6013-470	47.0 ± 30%	10	100K	2.52M	540	675	14	660	500
TPSH6013-680	68.0 ± 30%	10	100K	2.52M	720	900	10	600	400

Note:

- Measuring Frequency. L: 100KHz/0.25v.
- IDC: The current when the inductance becomes 35% lower than its nominal value. and temperature rise 40°C Δt = 40°C (ta = 20°C).



Electrical Characteristics (TPSH6018)

Part NO	Inductance (μH)	Q Ref.	TEST Freq.		DCR (mΩ)		SRF (MHz) TYP.	Irms (mA) TYP.	Isat (mA) TYP.
			L	Q	TYP.	MAX.			
TPSH6018-1R2	1.2 ± 30%	8	100K	7.96M	19	25	130	3600	2800
TPSH6018-1R8	1.8 ± 30%	8	100K	7.96M	22	28	90	3000	2300
TPSH6018-3R3	3.3 ± 30%	8	100K	7.96M	28	39	60	2500	1700
TPSH6018-4R7	4.7 ± 30%	8	100K	7.96M	32	42	50	2200	1400
TPSH6018-6R8	6.8 ± 30%	8	100K	7.96M	46	60	40	1900	1200
TPSH6018-100	10.0 ± 30%	12	100K	2.52M	68	88	30	1700	1000
TPSH6018-150	15.0 ± 30%	12	100K	2.52M	100	130	24	1500	800
TPSH6018-220	22.0 ± 30%	14	100K	2.52M	145	190	18	1200	650
TPSH6018-330	33.0 ± 30%	10	100K	2.52M	195	255	16	1000	580
TPSH6018-470	47.0 ± 30%	12	100K	2.52M	315	410	14	800	460
TPSH6018-680	68.0 ± 30%	12	100K	2.52M	455	600	12	620	360
TPSH6018-101	100.0 ± 30%	20	100K	2.52M	550	715	9	550	340

Note:

- Measuring Frequency. L: 100KHz/0.25v.
- IDC: The current when the inductance becomes 35% lower than its nominal value. and temperature rise 40°C Δt = 40°C (ta = 20°C).

Electrical Characteristics (TPSH6025)

Part NO	Inductance (μH)	Q Ref.	TEST Freq.		DCR (mΩ)		SRF (MHz) TYP.	Irms (mA) TYP.	Isat (mA) TYP.
			L	Q	TYP.	MAX.			
TPSH6025-2R2	2.2 ± 30%	8	100K	7.96M	18.5	24	65	3400	2350
TPSH6025-3R3	3.3 ± 30%	8	100K	7.96M	21.0	27	50	3200	2000
TPSH6025-4R7	4.7 ± 30%	8	100K	7.96M	27.0	35	42	2700	1550
TPSH6025-6R8	6.8 ± 30%	8	100K	7.96M	32.0	42	36	2400	1300
TPSH6025-8R2	8.2 ± 30%	8	100K	7.96M	40.0	52	30	2200	1250
TPSH6025-100	10.0 ± 30%	12	100K	2.52M	44.0	57	25	2000	1050
TPSH6025-150	15.0 ± 30%	12	100K	2.52M	66.0	86	22	1800	920
TPSH6025-220	22.0 ± 30%	12	100K	2.52M	100	130	18	1600	700
TPSH6025-330	33.0 ± 30%	12	100K	2.52M	140	12	65	1200	640
TPSH6025-470	47.0 ± 30%	12	100K	2.52M	190	250	10	1000	480
TPSH6025-680	68.0 ± 30%	10	100K	2.52M	280	500	7	700	350
TPSH6025-101	100.0 ± 30%	24	100K	796K	385	500	7	700	370
TPSH6025-221	220.0 ± 30%	20	100K	796K	950	1250	4	420	240

Note:

- Measuring Frequency. L: 100KHz/0.25v.
- IDC: The current when the inductance becomes 35% lower than its nominal value. and temperature rise 40°C Δt = 40°C (ta = 20°C).

TPSH80

Electrical Characteristics (TPSH8028)

Part NO	Inductance (μH)	Q Ref.	TEST Freq.		DCR (mΩ)		SRF (MHz) TYP.	Irms (mA) TYP.	Isat (mA) TYP.
			L	Q	TYP.	MAX.			
TPSH8028-3R3	3.3 ± 30%	12	100K	7.96M	60.0	17.5	23.0	3.60	3.50
TPSH8028-4R7	4.7 ± 30%	15	100K	7.96M	50.0	20.0	26.0	3.70	3.20
TPSH8028-6R8	6.8 ± 30%	13	100K	7.96M	40.0	34.0	45.0	2.80	2.50
TPSH8028-100	10.0 ± 30%	22	100K	2.52M	25.0	45.0	85.0	2.00	1.70
TPSH8028-150	15.0 ± 30%	20	100K	2.52M	20.0	66.0	130.0	1.60	1.50
TPSH8028-220	22 ± 30%	22	100K	2.52M	15.0	147.0	185.0	1.30	1.10
TPSH8028-470	47.0 ± 30%	14	100K	2.52M	12.0	177.0	230.0	1.20	1.00
TPSH8028-680	68 ± 30%	23	100K	2.52M	9.0	317.0	390.0	0.85	0.80

Note:

- Measuring Frequency. L: 100KHz/0.25v.
- IDC: The current when the inductance becomes 35% lower than its nominal value. and temperature rise 40°C Δt = 40°C (ta = 20°C).

Electrical Characteristics (TPSH8030)

Part NO	Inductance (μH)	Q Ref.	TEST Freq.		DCR (mΩ)		SRF (MHz) TYP.	Irms (mA) TYP.	Isat (mA) TYP.
			L	Q	TYP.	MAX.			
TPSH8030-3R3	3.3 ± 30%	12	100K	7.96M	55.0	15.6	22.0	5.00	4.60
TPSH8030-4R7	4.7 ± 30%	10	100K	7.96M	42.0	22.6	30.0	4.60	3.80
TPSH8030-6R8	6.8 ± 30%	10	100K	7.96M	30.0	34.5	46.0	3.60	3.20
TPSH8030-100	10.0 ± 30%	18	100K	2.52M	25.0	47.3	60.0	3.00	2.60
TPSH8030-150	15.0 ± 30%	18	100K	2.52M	20.0	75.0	100.0	2.20	2.00
TPSH8030-220	22.0 ± 30%	18	100K	2.52M	16.0	105.0	130.0	2.00	1.75
TPSH8030-330	33.0 ± 30%	16	100K	2.52M	12.0	205.0	260.0	1.45	1.25
TPSH8030-470	47.0 ± 30%	16	100K	2.52M	12.0	205.6	260.0	1.45	1.25
TPSH8030-680	68.0 ± 30%	16	100K	2.52M	9.0	25.6	315.0	1.25	0.96
TPSH8030-101	100.0 ± 30%	24	100K	0.796M	7.0	415.0	520.0	0.85	0.75

Note:

- Measuring Frequency. L: 100KHz/0.25v.
- IDC: The current when the inductance becomes 35% lower than its nominal value. and temperature rise 40°C Δt = 40°C (ta = 20°C).

Electrical Characteristics (TPSH8040)

Part NO	Inductance (μH)	Q Ref.	TEST Freq.		DCR (mΩ)		SRF (MHz) TYP.	Irms (mA) TYP.	Isat (mA) TYP.
			L	Q	TYP.	MAX.			
TPSH8040-3R3	3.3 ± 30%	12	100K	7.96M	40.0	13.8	18.0	6.00	5.00
TPSH8040-4R2	4.2 ± 30%	12	100K	7.96M	32.0	16.5	22.0	5.30	4.60
TPSH8040-6R2	6.2 ± 30%	10	100K	7.96M	28.0	25.0	32.0	4.20	4.00
TPSH8040-100	10.0 ± 30%	22	100K	2.52M	20.0	33.0	42.0	3.70	2.90
TPSH8040-150	15.0 ± 30%	20	100K	2.52M	18.0	55.0	70.0	2.80	2.50
TPSH8040-220	22.0 ± 30%	22	100K	2.52M	15.0	88	11.0	2.20	2.05
TPSH8040-330	33.0 ± 30%	22	100K	2.52M	12.0	115.0	150.0	1.90	1.75
TPSH8040-470	47.0 ± 30%	20	100K	2.52M	10.0	150.0	190.0	1.55	1.45
TPSH8040-680	68.0 ± 30%	18	100K	2.52M	8.0	205.0	260.0	1.35	1.10
TPSH8040-101	100.0 ± 30%	25	100K	0.796M	6.0	325.0	410.0	1.05	0.95
TPSH8040-151	150.0 ± 30%	18	100K	0.796M	5.0	445.0	560.0	0.90	0.77

Note:

- Measuring Frequency. L: 100KHz/0.25v.
- IDC: The current when the inductance becomes 35% lower than its nominal value. and temperature rise 40°C Δt = 40°C (ta = 20°C).

Electrical Characteristics (TPSH8043)

Part NO	Inductance (μH)	Q Ref.	TEST Freq.		DCR (mΩ)		SRF (MHz) TYP.	Irms (mA) TYP.	Isat (mA) TYP.
			L	Q	TYP.	MAX.			
TPSH8043-1R0	1.0 ± 30%	15	100K	7.96M	70.0	8.1	10.0	6.60	7.50
TPSH8043-2R2	2.2 ± 30%	15	100K	7.96M	65.0	11.2	15.0	5.40	5.20
TPSH8043-3R3	3.3 ± 30%	12	100K	7.96M	54.0	12.5	17.0	5.10	4.50
TPSH8043-3R9	3.9 ± 30%	15	100K	7.96M	42.0	14.6	19.0	4.80	4.00
TPSH8043-4R7	4.7 ± 30%	13	100K	7.96M	36.0	17.0	22.0	4.60	3.60
TPSH8043-100	10.0 ± 30%	27	100K	2.52M	20.0	30.0	40.0	3.50	2.70
TPSH8043-150	15.0 ± 30%	26	100K	2.52M	15.0	46.0	60.0	2.70	2.00
TPSH8043-220	22.0 ± 30%	24	100K	2.52M	12.0	72.5	95.0	2.20	1.70
TPSH8043-330	33.0 ± 30%	21	100K	2.52M	11.0	100.0	130.0	1.70	1.40
TPSH8043-470	47.0 ± 30%	21	100K	2.52M	9.0	120.0	150.0	1.50	1.20
TPSH8043-680	68.0 ± 30%	20	100K	2.52M	7.0	192.0	250.0	1.20	1.00
TPSH8043-101	100 ± 30%	50	100K	0.796M	6.0	287.0	370.0	1.00	0.80

Note:

- Measuring Frequency. L: 100KHz/0.25v.
- IDC: The current when the inductance becomes 35% lower than its nominal value. and temperature rise 40°C Δt = 40°C (ta = 20°C).

Electrical Characteristics (TPSH8045)

Part NO	Inductance (μH)	Q Ref.	TEST Freq.		DCR (mΩ)		SRF (MHz) TYP.	Irms (mA) TYP.	Isat (mA) TYP.
			L	Q	TYP.	MAX.			
TPSH8045-3R5	3.5 ± 30%	12	100K	7.96M	45.0	18.8	25.0	5.00	5.00
TPSH8045-4R7	4.7 ± 30%	10	100K	7.96M	30.0	22.0	27.5	4.60	4.40
TPSH8045-6R2	6.2 ± 30%	10	100K	7.96M	23.0	28.5	36.0	4.20	3.80
TPSH8045-100	10.0 ± 30%	16	100K	2.52M	18.0	35.8	48.0	3.50	3.30
TPSH8045-220	22.0 ± 30%	18	100K	2.52M	12.0	94.0	122.0	2.25	2.15
TPSH8045-330	33.0 ± 30%	14	100K	2.52M	8.0	118.0	150.0	2.00	1.80
TPSH8045-470	47.0 ± 30%	12	100K	2.52M	6.0	215.0	270.0	1.45	1.40
TPSH8045-680	68.0 ± 30%	8	100K	2.52M	4.0	320.0	400.0	1.25	1.20
TPSH8045-101	100.0 ± 30%	20	100K	0.70M	3.0	400.0	500.0	1.00	0.92

- Note:
- Measuring Frequency. L: 100KHz/0.25v.
- IDC: The current when the inductance becomes 35% lower than its nominal value. and temperature rise 40°C Δt = 40°C (ta = 20°C).

Electrical Characteristics (TPSH8058)

Part NO	Inductance (μH)	Q Ref.	TEST Freq.		DCR (mΩ)		SRF (MHz) TYP.	Irms (mA) TYP.	Isat (mA) TYP.
			L	Q	TYP.	MAX.			
TPSH8058-3R9	3.9 ± 30%	8	100K	7.96M	45.0	12.0	16.0	6.50	4.50
TPSH8058-5R2	5.2 ± 30%	8	100K	7.96M	35.0	14.0	17.5	5.80	3.90
TPSH8058-6R8	6.8 ± 30%	8	100K	7.96M	30.0	16.0	20.0	5.50	4.00
TPSH8058-100	10.0 ± 30%	20	100K	2.52M	14.0	42.0	52.0	3.40	1.80
TPSH8058-220	22.0 ± 30%	20	100K	2.52M	14.0	42.0	52.0	3.40	1.80
TPSH8058-330	33.0 ± 30%	16	100K	2.52M	10.0	58.0	72.0	2.70	1.60
TPSH8058-470	47.0 ± 30%	12	100K	2.52M	7.0	80.0	10.0	2.30	1.50
TPSH8058-680	68.0 ± 30%	16	100K	2.52M	6.0	100.0	130.0	2.00	1.20
TPSH8058-101	100.0 ± 30%	22	100K	0.796M	5.0	124.0	160.0	1.70	0.90

Note:

- Measuring Frequency. L: 100KHz/0.25v.
- IDC: The current when the inductance becomes 35% lower than its nominal value. and temperature rise 40°C Δt = 40°C (ta = 20°C).

TPSH10

Electrical Characteristics (TPSH1028)

Part NO	Inductance (μ H)	Q Ref.	SRF (MHz) TYP.	DCR (m Ω)		Irms (A) TYP.	Isat (A) TYP.
				TYP.	MAX.		
TPSH1028-1R0	1.0 \pm 30%	14	100	4.9	6.5	7.00	8.00
TPSH1028-1R5	1.5 \pm 30%	12	80	7.3	10.0	6.50	6.50
TPSH1028-2R2	2.2 \pm 30%	12	65	11.0	15.0	5.30	4.80
TPSH1028-3R3	3.3 \pm 30%	14	55	15.0	20.0	4.60	4.30
TPSH1028-4R7	4.7 \pm 30%	12	40	16.5	3.0	4.50	3.80
TPSH1028-6R8	6.8 \pm 30%	12	30	25.0	33.0	3.50	3.00
TPSH1028-8R2	8.2 \pm 30%	12	28	28.5	37.0	3.30	2.70
TPSH1028-100	10.0 \pm 30%	20	25	40.0	53.0	2.80	2.40
TPSH1028-150	15.0 \pm 30%	26	22	69.0	90.0	2.00	2.00
TPSH1028-220	22.0 \pm 30%	26	16	104.0	135.0	1.60	1.40
TPSH1028-330	33.0 \pm 30%	24	12	139.0	180.0	1.25	1.20
TPSH1028-470	47.0 \pm 30%	20	11	167.0	230.0	1.30	1.10
TPSH1028-560	56.0 \pm 30%	22	10	208.0	270.0	1.10	1.00
TPSH1028-680	68.0 \pm 30%	20	9	232.0	300.0	1.00	0.90
TPSH1028-820	82.0 \pm 30%	20	8	323.0	420.0	0.90	0.85
TPSH1028-101	100.0 \pm 30%	20	7	365.0	470.0	0.85	0.80
TPSH1028-121	120.0 \pm 30%	18	6	428.0	560.0	0.65	0.70
TPSH1028-151	150.0 \pm 30%	18	5	518.0	680.0	0.70	0.65

Note:

- Measuring Frequency. L: 100KHz/0.25v.
- IDC: The current when the inductance becomes 35% lower than its nominal value. and temperature rise 40°C Δ t = 40°C (ta = 20°C).

Electrical Characteristics (TPSH1030)

Part NO	Inductance (μ H)	Q Ref.	SRF (MHz) TYP.	DCR (m Ω)		Irms (A) TYP.	Isat (A) TYP.
				TYP.	MAX.		
TPSH1030-4R7	4.7 \pm 30%	14	36	25.0	32.5	4.20	4.40
TPSH1030-6R2	6.2 \pm 30%	12	30	32.0	42.0	3.80	3.90
TPSH1030-100	10.0 \pm 30%	16	26	44.0	58.0	3.00	3.10
TPSH1030-150	15.0 \pm 30%	16	22	73.0	95.0	2.60	2.55
TPSH1030-220	22.0 \pm 30%	16	18	110.0	145.0	2.00	2.10
TPSH1030-330	33.0 \pm 30%	12	14	150.0	195.0	1.70	1.74
TPSH1030-470	47.0 \pm 30%	14	12	210.0	270.0	1.40	1.35
TPSH1030-680	68.0 \pm 30%	14	10	285.0	370.0	1.20	1.22
TPSH1030-101	100.0 \pm 30%	14	8.5	395.0	520.0	1.10	1.02
TPSH1030-151	150.0 \pm 30%	12	5.5	640.0	840.0	0.85	0.84

Note:

- Measuring Frequency. L: 100KHz/0.25v.
- IDC: The current when the inductance becomes 35% lower than its nominal value. and temperature rise 40°C Δ t = 40°C (ta = 20°C).

Electrical Characteristics (TPSH1038)

Part NO	Inductance (μH)	Q Ref.	SRF (MHz) TYP.	DCR (mΩ)		Irms (A) TYP.	Isat (A) TYP.
				TYP.	MAX.		
TPSH1038-1R5	1.5 ± 30%	14	65	5.2	7.5	7.20	7.00
TPSH1038-2R2	2.2 ± 30%	12	55	7.7	10.5	6.80	6.50
TPSH1038-3R5	3.5 ± 30%	14	35	11.5	15.0	5.50	5.50
TPSH1038-5R0	5.0 ± 30%	12	30	14.5	22.0	4.60	4.80
TPSH1038-6R2	6.2 ± 30%	12	25	16.5	24.0	4.00	4.20
TPSH1038-100	10.0 ± 30%	24	20	25.0	35.0	3.80	3.60
TPSH1038-150	15.0 ± 30%	24	16	37.0	50.0	2.80	2.70
TPSH1038-220	22.0 ± 30%	20	12	55.8	75.0	2.20	2.30
TPSH1038-330	33.0 ± 30%	22	10	86.0	112.0	1.80	1.80
TPSH1038-470	47.0 ± 30%	22	8	121.0	160.0	1.65	1.60
TPSH1038-680	68.0 ± 30%	24	6	220.0	300.0	1.30	1.10
TPSH1038-101	100.0 ± 30%	24	6	220.0	300.0	1.30	1.10
TPSH1038-151	150.0 ± 30%	20	5	358.0	476.0	0.90	0.80
TPSH1038-221	220.0 ± 30%	22	4	565.0	740.0	0.65	0.65
TPSH1038-331	330.0 ± 30%	20	3	773.0	1000.0	0.55	0.52

Note:

- Measuring Frequency. L: 100KHz/0.25v.
- IDC: The current when the inductance becomes 35% lower than its nominal value. and temperature rise 40°C Δt = 40°C (ta = 20°C).

Electrical Characteristics (TPSH1040)

Part NO	Inductance (μH)	Q Ref.	SRF (MHz) TYP.	DCR (mΩ)		Irms (A) TYP.	Isat (A) TYP.
				TYP.	MAX.		
TPSH1040-5R0	5.0 ± 30%	12	28.0	17.5	23.0	5.20	4.70
TPSH1040-6R2	6.2 ± 30%	12	24.0	21.5	28.0	4.70	4.30
TPSH1040-100	10.0 ± 30%	16	22.0	32.0	42.0	4.40	3.80
TPSH1040-150	15.0 ± 30%	18	16.0	60.0	78.0	2.90	2.80
TPSH1040-220	22.0 ± 30%	16	12.0	75.0	98.0	2.55	2.48
TPSH1040-330	33.0 ± 30%	16	10.0	110.0	140.0	2.05	2.00
TPSH1040-470	47.0 ± 30%	16	8.0	170.0	22.0	1.62	1.56
TPSH1040-680	68.0 ± 30%	16	7.0	245.0	320.0	1.45	1.40
TPSH1040-101	100.0 ± 30%	14	6.0	320.0	415.0	1.18	1.14
TPSH1040-221	220.0 ± 30%	14	4.0	760.0	950.0	0.78	0.72
TPSH1040-331	330.0 ± 30%	14	2.5	1080.0	1350.0	0.62	0.60

Note:

- Measuring Frequency. L: 100KHz/0.25v.
- IDC: The current when the inductance becomes 35% lower than its nominal value. and temperature rise 40°C Δt = 40°C (ta = 20°C).



Electrical Characteristics (TPSH1050)

Part NO	Inductance (μH)	Q Ref.	SRF (MHz) TYP.	DCR (mΩ)		Irms (A) TYP.	Isat (A) TYP.
				TYP.	MAX.		
TPSH1050-4R7	4.7 ± 30%	13	34.0	14.5	19.0	5.20	5.10
TPSH1050-100	10.0 ± 30%	16	20.0	26.0	34.0	4.40	3.80
TPSH1050-220	22.0 ± 30%	16	10.0	58.0	76.0	2.90	2.70
TPSH1050-330	33.0 ± 30%	14	8.5	70.0	90.0	2.70	2.10
TPSH1050-470	47.0 ± 30%	14	7.0	100.0	130.0	2.10	1.80
TPSH1050-680	68.0 ± 30%	14	6.5	144.0	186.0	1.75	1.45
TPSH1050-101	100.0 ± 30%	16	5.0	198.0	260.0	1.50	1.25
TPSH1050-151	150.0 ± 30%	16	4.0	330.0	430.0	1.15	1.05
TPSH1050-221	220.0 ± 30%	14	3.5	470.0	610.0	0.95	0.88
TPSH1050-331	330.0 ± 30%	11	2.5	690.0	900.0	0.84	0.70
TPSH1050-471	470.0 ± 30%	11	1.9	1050.0	1350.0	0.65	0.55
TPSH1050-681	680.0 ± 30%	11	1.6	1350.0	1760.0	0.56	0.48
TPSH1050-102	1000.0 ± 30%	30	1.4	2120.0	2760.0	0.47	0.40

Note:

- Measuring Frequency. L: 100KHz/0.25v.
- IDC: The current when the inductance becomes 35% lower than its nominal value. and temperature rise 40°C Δt = 40°C (ta = 20°C).

Electrical Characteristics (TPSH1065)

Part NO	Inductance (μH)	Q Ref.	SRF (MHz) TYP.	DCR (mΩ)		Irms (A) TYP.	Isat (A) TYP.
				TYP.	MAX.		
TPSH1065-4R2	4.2 ± 30%	14	45	18.0	23.0	5.60	7.00
TPSH1065-6R5	6.5 ± 30%	13	28	28.0	35.0	5.00	7.00
TPSH1065-100	10.0 ± 30%	14	20	33.0	41.0	4.90	4.00
TPSH1065-220	22.0 ± 30%	16	12	58.0	73.0	3.80	2.80
TPSH1065-330	33.0 ± 30%	10	7	93.0	120.0	2.70	2.40
TPSH1065-470	47.0 ± 30%	10	6	165.0	210.0	2.10	2.10
TPSH1065-680	68.0 ± 30%	8	5	195.0	250.0	1.85	1.75
TPSH1065-101	100.0 ± 30%	13	4	234.0	290.0	1.80	1.40

Note:

- Measuring Frequency. L: 100KHz/0.25v.
- IDC: The current when the inductance becomes 35% lower than its nominal value. and temperature rise 40°C Δt = 40°C (ta = 20°C).



▶ **Order Codes**

Order Codes (TPSH)

TPSH6011			-	1R0		M	
Part Number				Inductance		Tolerance	
TPSH6011	TPSH6013	TPSH6018		1R0	1.00μH	J	±5%
TPSH6025	TPSH8028	TPSH8030		120	12.00μH	K	±10%
TPSH8040	TPSH8043	TPSH8045		220	22.00μH	L	±15%
TPSH8058	TPSH1028	TPSH1030		101	100.00μH	M	±20%
TPSH1038	TPSH1040	TPSH1050		102	1000.00μH	P	±25%
TPSH1065						N	±30%

► General Information

How to Quickly Search Inductor for all of the Characteristics?

Quickly Search Inductor Finder

Searching and comparing data sheets of inductor manufacturers can be time consuming. Token's Parameter Sorting Search Mode allows selection of inductors based on different parameters.

By entering just the inductance value,

By sorting parameter to narrow down searching range,

Or by enter keyword / part number / size dimensions L*W*H to partial or exact searching.

Leading-Edge Technology

Token Electronics brand passive component specializes in standard and custom solutions offering the latest in state-of-the-art low profile high power density inductor components. Token provides cost-effective, comprehensive solutions that meet the evolving needs of technology-driven markets. In working closely with the industry leaders in chipset and core development, we remain at the forefront of innovation and new technology to deliver the optimal mix of packaging, high efficiency and unbeatable reliability. Our designs utilize high frequency, low core loss materials, new and custom core shapes in combination with innovative construction and packaging to provide designers with the highest performance parts available on the market.

Find Inductor Solutions Faster

Find Your Inductor - wt.moc.nekot@qfr

Only timely and accurate information can help manage the changing needs of your customers. The Token Inductor Finder puts you only a click away from all of the inductor information you need.

Find Your Solution - wt.moc.nekot@qfr

Selecting the correct inductor solution will not only save you time, but it will give you a competitive edge. At Token, we are committed to helping you find the most efficient alternative for your power design. Our inductor and power supply design experts can help you make that selection.

Please forward us:

- A brief description of your particular application's requirements.
- Details of an existing solution that you'd like to replace, enhance or find an alternative.
- Inquiries for feasibility to tailor a power transformer or inductor to your specific application.

We can also help you with any additional technical information you might need relating to any of our products.

Ask Us Today